



TOWN OF ORANGETOWN
OFFICE OF BUILDING, ZONING, PLANNING
ADMINISTRATION AND ENFORCEMENT

Jane Slavin, R.A.
Director

845-359-8410

Fax 845-359-8526

Checklist of items required for RESIDENTIAL DECK PERMIT:

ALL ITEMS ON THIS LIST ARE REQUIRED WHEN THE PERMIT IS SUBMITTED:

- ___ Completed Building Permit Application (every section that applies to project)
- ___ Copy of contractors **Rockland County License, New York State Workers Compensation & Disability Insurance** **WE DO NOT ACCEPT THE ACCORD FORM**
(Refer to the Items Required from Contractor Package)
- or- ___ Completed and notarized Homeowners Affidavit
- ___ **2 copies of property survey** showing existing property conditions and location of the proposed deck (drawn to scale) including measurements from deck to house / property lines
- ___ **2 copies of legible deck plans** (Refer to Deck Requirements Package)
- ___ (IF plans are larger than size 11"x17", a 3rd COPY is required either a hardcopy ,size 11"x17" or an electronic copy; PDF's can be emailed to the building dept clerks at the time the permit is submitted)
- ___ **2 checks, made payable to "Town of Orangetown"** (or cash):
 - \$20 for residential database fee and
 - \$_____ permit fee based on the estimated cost of construction*
(Decks are estimated at \$50 per square foot if using composite material and \$35 per square foot for pressure treated material)
 - *Even if the homeowner is doing the work, the estimated cost must be based on what it would cost if a contractor was to do the work.
 - Permit fee calculation: \$150 for the first \$1,000 of estimated construction value +\$18 for each additional \$1,000**

PLEASE NOTE: WORK CANNOT BE STARTED UNTIL THE RED BALL PERMIT NOTICE IS ISSUED, SIGNED OUT AND POSTED ON THE PROPERTY.

ONCE ISSUED, A BUILDING PERMIT IS VALID FOR 2 YEARS. THE PERMIT IS NOT COMPLETE UNTIL THE FINAL INSPECTION IS REQUESTED BY THE OWNER AND/OR OWNERS REPRESENTATIVE. THE FINAL INSPECTION MUST BE DEEMED SATISFACTORY BY THE BUILDING INSPECTOR, AT WHICH TIME A COPY OF THE CERTIFICATE OF OCCUPANCY WILL BE MAILED TO THE HOMEOWNER.

OPEN EXPIRED PERMITS WILL RESULT IN PROPERTY VIOLATIONS. TO RENEW AN OPEN EXPIRED PERMIT THERE IS A FEE.

emd 02/2018



**OFFICE OF BUILDING, ZONING, PLANNING
ADMINISTRATION AND ENFORCEMENT
TOWN OF ORANGETOWN
20 GREENBUSH ROAD
ORANGETOWN, N.Y. 10962**

**Jane Slavin, RA
Director**

(845) 359-8410

Fax: (845) 359-8526

REQUIRED DOCUMENTATION FOR DECK APPLICATIONS

Please submit the following documentation in **duplicate**.

All construction drawings must be legible and to scale.

- I. Property survey or site plan indicating location of deck with dimensions and distances from property lines.
- II. Construction drawings must contain the following information:
 - 1) ___ Proposed deck in relation to existing structure noting location, dimensions and height above grade.
 - 2) ___ Pier footing type and size, footing depth, location and distances between piers and connectors.
 - 3) ___ Beam size, spans between beam and structure and spans between beams and connectors.
 - 4) ___ Beam support post size and connection to posts.
 - 5) ___ Ledger size, flashing details and lateral connection to house.
 - 6) ___ Size and spacing of deck joists.
 - 7) ___ Lateral bracing detail.
 - 8) ___ Type, size and orientation of decking and fasteners.
 - 9) ___ Location of stairs, stringer size and spacing of stringers.
 - 10) ___ Stair treads, type and size.
 - 11) ___ Landing material and dimensions.
 - 12) ___ Guard and handrail height and spacing and connection detail.

SUBMITTED BY: _____

DATE: _____

By signing below, the applicant/agent agrees that they have completed and supplied all items listed above and applicant understands that incomplete submissions may delay review and issuance of building permit.

Contact Person Name: _____ **Signature:** _____

Project Address: _____

Section: _____ **Block:** _____ **Lot:** _____ **Phone No:** _____

Email Address of Contact Person: _____

Residence

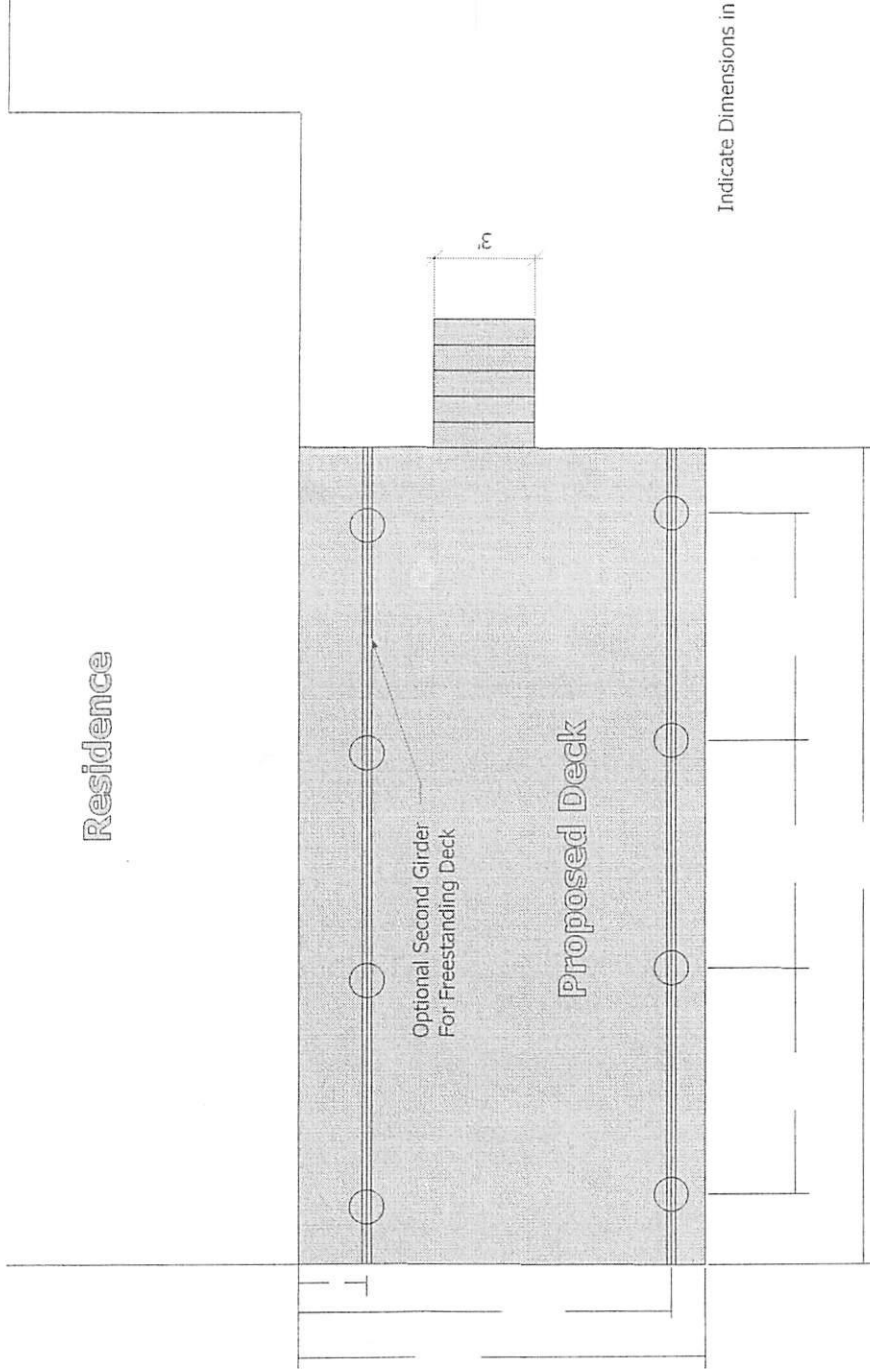

Indicate Dimensions in Spaces Provided

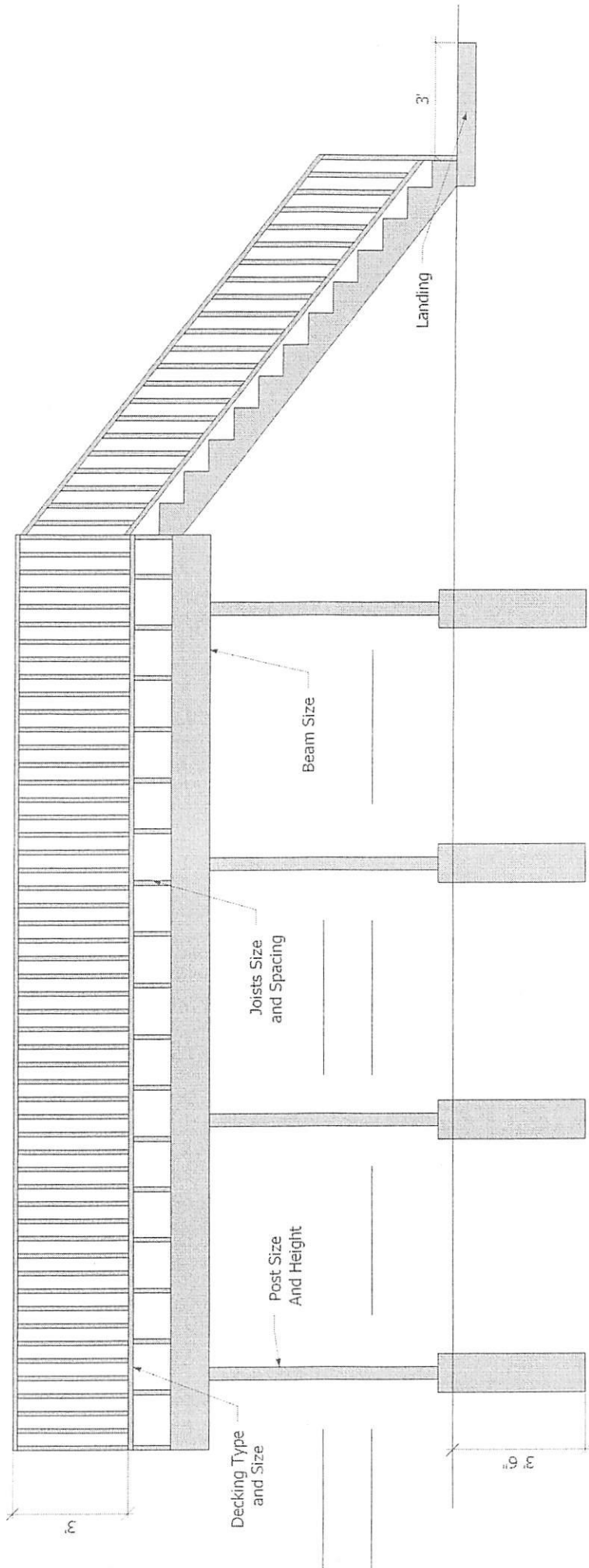

Indicate Component Details in Space Provided

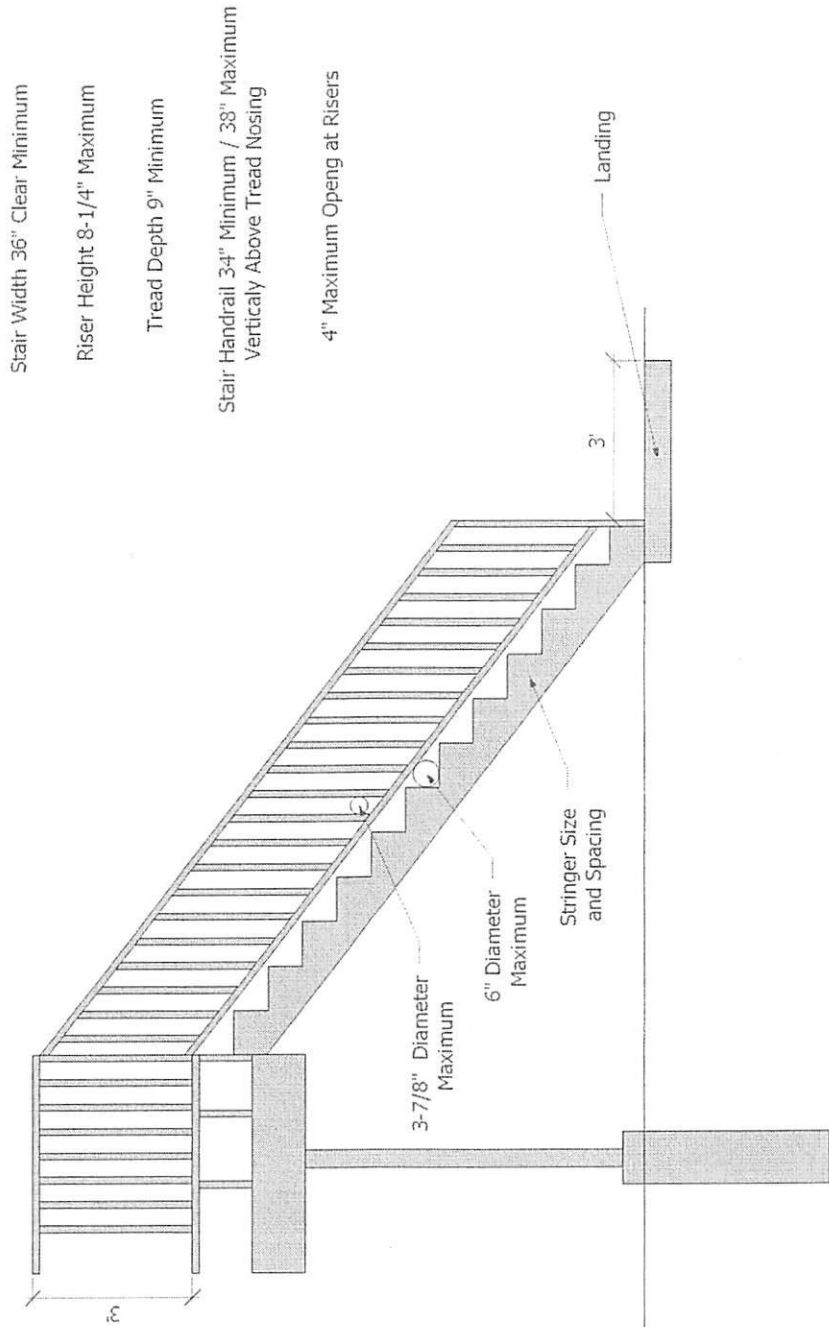

SECTION R507 EXTERIOR DECKS

R507.1 Decks.

Wood-framed decks shall be in accordance with this section or Section R301 for materials and conditions not prescribed herein. Where supported by attachment to an exterior wall, decks shall be positively anchored to the primary structure and designed for both vertical and lateral loads.

Such attachment shall not be accomplished by the use of toenails or nails subject to withdrawal. Where positive connection to the primary building structure cannot be verified during inspection, decks shall be self-supporting. For decks with cantilevered framing members connections to exterior walls or other framing members shall be designed and constructed to resist uplift resulting from the full live load specified in Table R301.5 acting on the cantilevered portion of the deck.

R507.2 Deck ledger connection to band joist.

Deck ledger connections to band joists shall be in accordance with this section, Tables R507.2 and R507.2.1, and Figures R507.2.1(1) and R507.2.1(2). For other grades, species, connection details and loading conditions, deck ledger connections shall be designed in accordance with Section R301.

TABLE R507.2
DECK LEDGER CONNECTION TO BAND JOIST^{a, b} (Deck live load = 40 psf, deck dead load = 10 psf, snow load ≤ 40 psf)

CONNECTION DETAILS	JOIST SPAN						
	6' and less	6'1" to 8'	8'1" to 10'	10'1" to 12'	12'1" to 14'	14'1" to 16'	16'1" to 18'
	On-center spacing of fasteners						
1/2-inch diameter lag screw with 1/2-inch maximum sheathing ^{c, d}	30	23	18	15	13	11	10
1/2-inch diameter bolt with 1/2-inch maximum sheathing ^d	36	36	34	29	24	21	19
1/2-inch diameter bolt with 1-inch maximum sheathing ^e	36	36	29	24	21	18	16

For SI: 1 inch = 25.4 mm, 1 foot = 304.8 mm, 1 pound per square foot = 0.0479 kPa.

- a. Ledgers shall be flashed in accordance with Section R703.4 to prevent water from contacting the house band joist.
- b. Snow load shall not be assumed to act concurrently with live load.
- c. The tip of the lag screw shall fully extend beyond the inside face of the band joist.
- d. Sheathing shall be wood structural panel or solid sawn lumber.
- e. Sheathing shall be permitted to be wood structural panel, gypsum board, fiberboard, lumber or foam sheathing. Up to 1/2-inch thickness of stacked washers shall be permitted to substitute for up to 1/2 inch of allowable sheathing thickness where combined with wood structural panel or lumber sheathing.

R507.2.1 Ledger details.

Deck ledgers installed in accordance with Section R507.2 shall be a minimum 2-inch by 8-inch (51 mm by 203 mm) nominal, pressure-preservative-treated southern pine, incised pressure-preservative-treated Hem-fir, or approved, naturally durable, No. 2 grade or better lumber. Deck ledgers installed in accordance with Section R507.2 shall not support concentrated loads from beams or girders. Deck ledgers shall not be supported on stone or masonry veneer.

TABLE R507.2.1
PLACEMENT OF LAG SCREWS AND BOLTS IN DECK LEDGERS AND BAND JOISTS

MINIMUM END AND EDGE DISTANCES AND SPACING BETWEEN ROWS				
	TOP EDGE	BOTTOM EDGE	ENDS	ROW SPACING
Ledger ^a	2 inches ^d	3/4 inch	2 inches ^b	1 5/8 inches ^b
Band Joist ^c	3/4 inch	2 inches	2 inches ^b	1 5/8 inches ^b

For SI: 1 inch = 25.4 mm.

- Lag screws or bolts shall be staggered from the top to the bottom along the horizontal run of the deck ledger in accordance with Figure R507.2.1(1).
- Maximum 5 inches.
- For engineered rim joists, the manufacturer's recommendations shall govern.
- The minimum distance from bottom row of lag screws or bolts to the top edge of the ledger shall be in accordance with Figure R507.2.1(1).

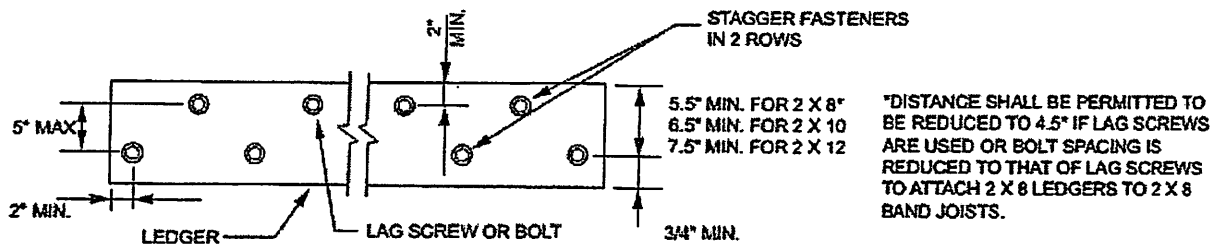

For SI: 1 inch = 25.4 mm.

FIGURE R507.2.1(1)
PLACEMENT OF LAG SCREWS AND BOLTS IN LEDGERS

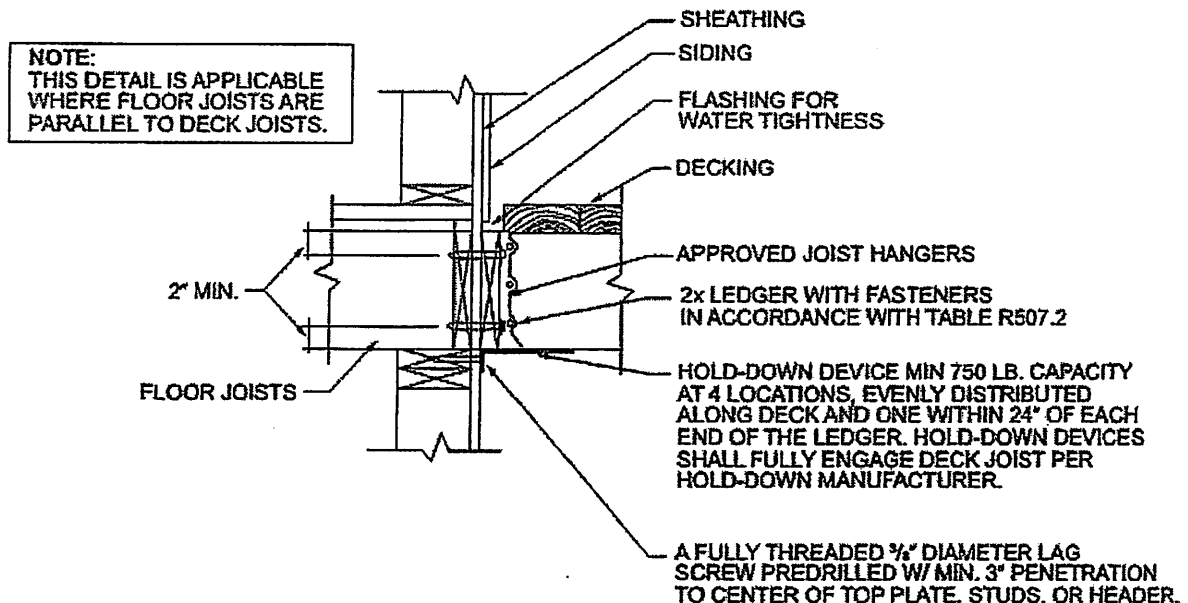

For SI: 1 inch = 25.4 mm.

FIGURE R507.2.1(2)
PLACEMENT OF LAG SCREWS AND BOLTS IN BAND JOISTS

R507.2.2 Band joist details.

Band joists attached by a ledger in accordance with Section R507.2 shall be a minimum 2-inch-nominal (51 mm), solid-sawn, spruce-pine-fir lumber or a minimum 1-inch by 9 1/2-inch (25 mm x 241 mm) dimensional, Douglas fir, laminated veneer lumber. Band joists attached by a ledger in accordance with Section R507.2 shall be fully supported by a wall or sill plate below.

R507.2.3 Ledger to band joist fastener details.

Fasteners used in deck ledger connections in accordance with Table R507.2 shall be hot-dipped galvanized or stainless steel and shall be installed in accordance with Table R507.2.1 and Figures R507.2.1(1) and R507.2.1(2).

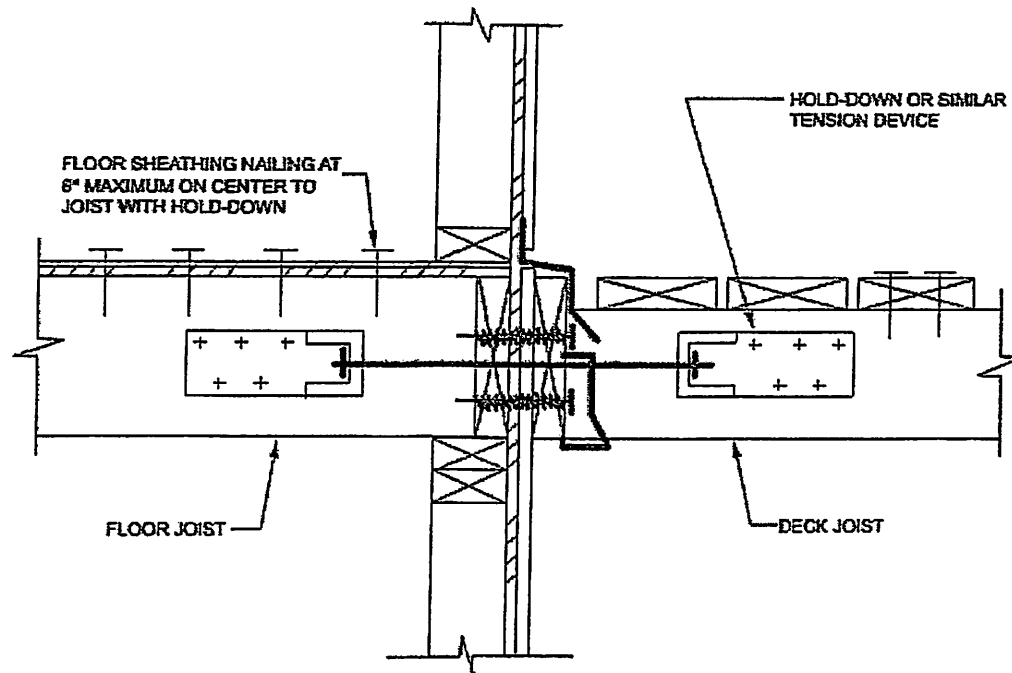

For SI: 1 inch = 25.4 mm.

FIGURE 507.2.3(1)
DECK ATTACHMENT FOR LATERAL LOADS

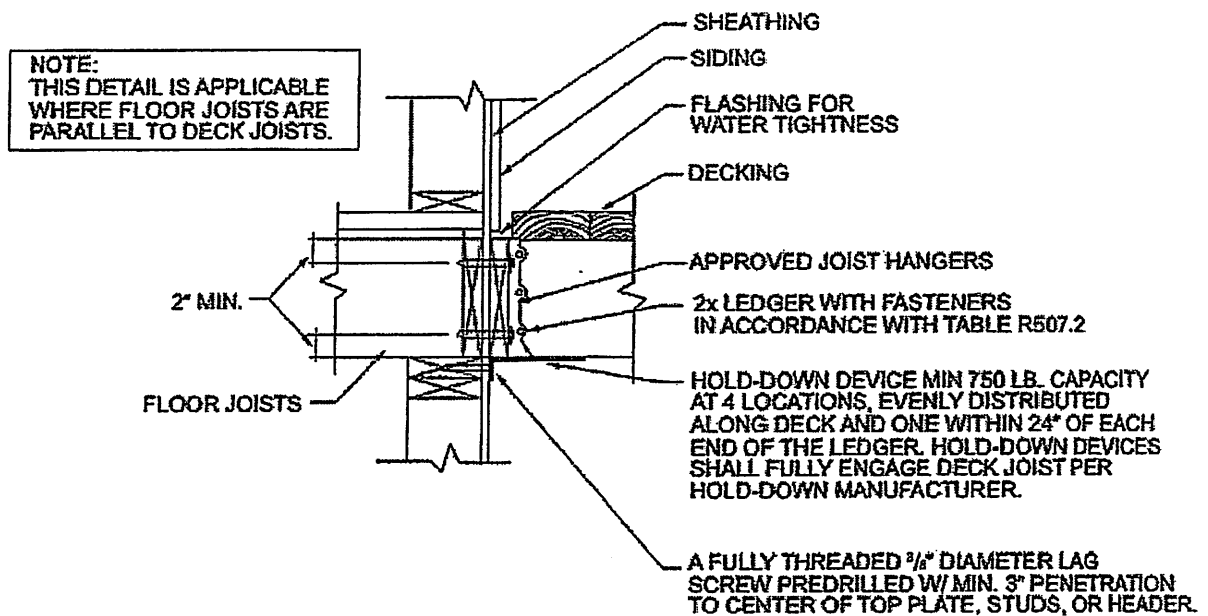

For SI: 1 inch = 25.4 mm, 1 foot = 304.8 mm.

FIGURE R507.2.3(2)
DECK ATTACHMENT FOR LATERAL LOADS

R507.2.4 Deck lateral load connection.

The lateral load connection required by Section R507.1 shall be permitted to be in accordance with Figure R507.2.3(1) or R507.2.3(2). Where the lateral load connection is provided in accordance with Figure R507.2.3(1), hold-down tension devices shall be installed in not less than two locations per deck, within 24

inches of each end of the deck. Each device shall have an allowable stress design capacity of not less than 1,500 pounds (6672 N). Where the lateral load connections are provided in accordance with Figure R507.2.3(2), the hold-down tension devices shall be installed in not less than four locations per deck, and each device shall have an allowable stress design capacity of not less than 750 pounds (3336 N).

R507.3 Plastic composite deck boards, stair treads, guards, or handrails.

Plastic composite exterior deck boards, stair treads, guards and handrails shall comply with the requirements of ASTM D 7032 and the requirements of Section 507.3.

R507.3.1 Labeling.

Plastic composite deck boards and stair treads, or their packaging, shall bear a label that indicates compliance to ASTM D 7032 and includes the allowable load and maximum allowable span determined in accordance with ASTM D 7032. Plastic or composite handrails and guards, or their packaging, shall bear a label that indicates compliance to ASTM D 7032 and includes the maximum allowable span determined in accordance with ASTM D 7032.

R507.3.2 Flame spread index.

Plastic composite deck boards, stair treads, guards, and handrails shall exhibit a flame spread index not exceeding 200 when tested in accordance with ASTM E 84 or UL 723 with the test specimen remaining in place during the test.

Exception: Plastic composites determined to be non-combustible.

R507.3.3 Decay resistance.

Plastic composite deck boards, stair treads, guards and handrails containing wood, cellulosic or other biodegradable materials shall be decay resistant in accordance with ASTM D 7032.

R507.3.4 Termite resistance.

Where required by Section 318, plastic composite deck boards, stair treads, guards and handrails containing wood, cellulosic or other biodegradable materials shall be termite resistant in accordance with ASTM D 7032.

507.3.5 Installation of plastic composites.

Plastic composite deck boards, stair treads, guards and handrails shall be installed in accordance with this code and the manufacturer's instructions.

R507.4 Decking.

Maximum allowable spacing for joists supporting decking shall be in accordance with Table R507.4. Wood decking shall be attached to each supporting member with not less than (2) 8d threaded nails or (2) No. 8 wood screws.

**TABLE R507.4
MAXIMUM JOIST SPACING**

MATERIAL TYPE AND NOMINAL SIZE	MAXIMUM ON-CENTER JOIST SPACING	
	Perpendicular to joist	Diagonal to joist ^a
1 1/4-inch-thick wood	16 inches	12 inches
2-inch-thick wood	24 inches	16 inches
Plastic composite	In accordance with Section R507.3	In accordance with Section R507.3

For SI: 1 inch = 25.4 mm, 1 foot = 304.8 mm, 1 degree = 0.01745 rad.

a. Maximum angle of 45 degrees from perpendicular for wood deck boards

R507.5 Deck joists.

Maximum allowable spans for wood deck joists, as shown in Figure R507.5, shall be in accordance with Table R507.5. Deck joists shall be permitted to cantilever not greater than one-fourth of the actual, adjacent joist span.

**TABLE R507.5
DECK JOIST SPANS FOR COMMON LUMBER SPECIES^f (ft. - in.)**

SPECIES ^a	SIZE	SPACING OF DECK JOISTS WITH NO CANTILEVER ^b (inches)			SPACING OF DECK JOISTS WITH CANTILEVERS ^c (inches)		
		12	16	24	12	16	24
Southern pine	2 x 6	9-11	9-0	7-7	6-8	6-8	6-8
	2 x 8	13-1	11-10	9-8	10-1	10-1	9-8
	2 x 10	16-2	14-0	11-5	14-6	14-0	11-5
	2 x 12	18-0	16-6	13-6	18-0	16-6	13-6
Douglas fir-larch ^d , hem-fir ^d spruce-pine-fir ^d	2 x 6	9-6	8-8	7-2	6-3	6-3	6-3
	2 x 8	12-6	11-1	9-1	9-5	9-5	9-1
	2 x 10	15-8	13-7	11-1	13-7	13-7	11-1
	2 x 12	18-0	15-9	12-10	18-0	15-9	12-10
Redwood, western cedars, ponderosa pine ^e , red pine ^e	2 x 6	8-10	8-0	7-0	5-7	5-7	5-7
	2 x 8	11-8	10-7	8-8	8-6	8-6	8-6
	2 x 10	14-11	13-0	10-7	12-3	12-3	10-7
	2 x 12	17-5	15-1	12-4	16-5	15-1	12-4

For SI: 1 inch = 25.4 mm, 1 foot = 304.8 mm, 1 pound per square foot = 0.0479 kPa, 1 pound = 0.454 kg.

- No. 2 grade with wet service factor.
- Ground snow load, live load = 40 psf, dead load = 10 psf, L/Δ = 360.
- Ground snow load, live load = 40 psf, dead load = 10 psf, L/Δ = 360 at main span, L/Δ = 180 at cantilever with a 220-pound point load applied to end.
- Includes incising factor.
- Northern species with no incising factor
- Cantilevered spans not exceeding the nominal depth of the joist are permitted.

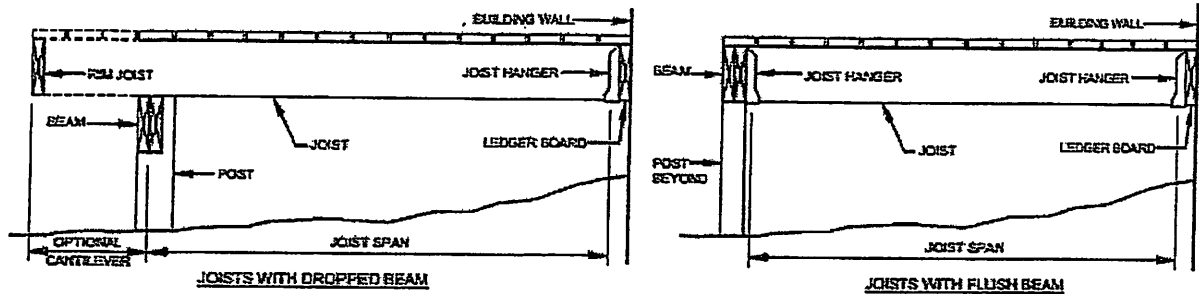

FIGURE R507.5
TYPICAL DECK JOIST SPANS

R507.5.1 Lateral restraint at supports.

Joist ends and bearing locations shall be provided with lateral restraint to prevent rotation. Where lateral restraint is provided by joist hangers or blocking between joists, their depth shall equal not less than 60 percent of the joist depth. Where lateral restraint is provided by rim joists, they shall be secured to the end of each joist with not less than (3) 10d (3-inch × 0.128-inch) nails or (3) No. 10 × 3-inch (76 mm) long wood screws.

R507.6 Deck Beams.

Maximum allowable spans for wood deck beams, as shown in Figure R507.6, shall be in accordance with Table R507.6. Beam plies shall be fastened with two rows of 10d (3-inch × 0.128-inch) nails minimum at 16 inches (406 mm) on center along each edge. Beams shall be permitted to cantilever at each end up to one-fourth of the actual beam span. Splices of multispan beams shall be located at interior post locations.

TABLE R507.6
DECK BEAM SPAN LENGTHS^{a, b} (ft. - in.)

SPECIES ^c	SIZE ^d	DECK JOIST SPAN LESS THAN OR EQUAL TO: (feet)						
		6	8	10	12	14	16	18
Southern pine	2 - 2 × 6	6-11	5-11	5-4	4-10	4-6	4-3	4-0
	2 - 2 × 8	8-9	7-7	6-9	6-2	5-9	5-4	5-0
	2 - 2 × 10	10-4	9-0	8-0	7-4	6-9	6-4	6-0
	2 - 2 × 12	12-2	10-7	9-5	8-7	8-0	7-6	7-0
	3 - 2 × 6	8-2	7-5	6-8	6-1	5-8	5-3	5-0
	3 - 2 × 8	10-10	9-6	8-6	7-9	7-2	6-8	6-4
	3 - 2 × 10	13-0	11-3	10-0	9-2	8-6	7-11	7-6
	3 - 2 × 12	15-3	13-3	11-10	10-9	10-0	9-4	8-10
	3 × 6 or 2 - 2 × 6	5-5	4-8	4-2	3-10	3-6	3-1	2-9
	3 × 8 or 2 - 2 × 8	6-10	5-11	5-4	4-10	4-6	4-1	3-8

Douglas fir-larch^e, hem-fir^e, spruce-pine-fir^e,
redwood, western cedars, ponderosa pine^f, red pine^f

3 × 10 or 2 - 2 × 10	8-4	7-3	6-6	5- 11	5-6	5-1	4-8
3 × 12 or 2 - 2 × 12	9-8	8-5	7-6	6- 10	6-4	5- 11	5-7
4 × 6	6-5	5-6	4-11	4-6	4-2	3- 11	3-8
4 × 8	8-5	7-3	6-6	5- 11	5-6	5-2	4- 10
4 × 10	9-11	8-7	7-8	7-0	6-6	6-1	5-8
4 × 12	11-5	9- 11	8-10	8-1	7-6	7-0	6-7
3 - 2 × 6	7-4	6-8	6-0	5-6	5-1	4-9	4-6
3 - 2 × 8	9-8	8-6	7-7	6- 11	6-5	6-0	5-8
3 - 2 × 10	12-0	10- 5	9-4	8-6	7- 10	7-4	6- 11
3 - 2 × 12	13- 11	12- 1	10-9	9- 10	9-1	8-6	8-1

For SI: 1 inch = 25.4 mm, 1 foot = 304.8 mm, 1 pound per square foot = 0.0479 kPa, 1 pound = 0.454 kg.

- Ground snow load, live load = 40 psf, dead load = 10 psf, $L/\Delta = 360$ at main span. $L/\Delta = 180$ at cantilever with a 220-pound point load applied at the end.
- Beams supporting deck joists from one side only.
- No. 2 grade, wet service factor.
- Beam depth shall be greater than or equal to depth of joists with a flush beam condition.
- Includes incising factor.
- Northern species. Incising factor not included.

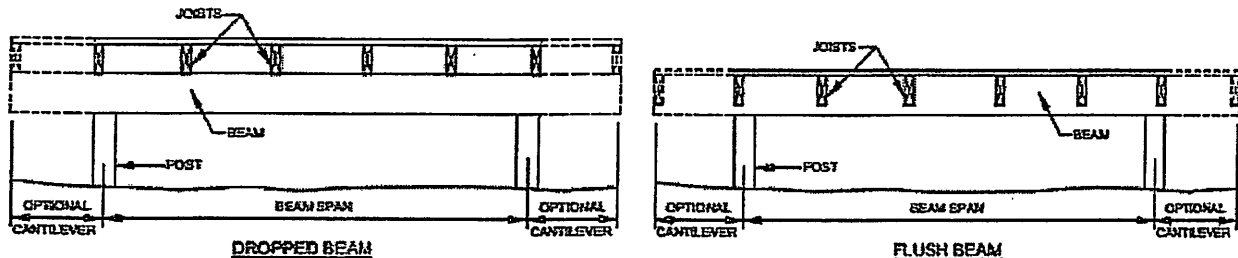

FIGURE R507.6
TYPICAL DECK BEAM SPANS

R507.7 Deck joist and deck beam bearing.

The ends of each joist and beam shall have not less than 1½ inches (38 mm) of bearing on wood or metal and not less than 3 inches (76 mm) on concrete or masonry for the entire width of the beam. Joist framing into the side of a ledger board or beam shall be supported by approved joist hangers. Joists bearing on a beam shall be connected to the beam to resist lateral displacement.

R507.7.1 Deck post to deck beam.

Deck beams shall be attached to deck posts in accordance with Figure R507.7.1 or by other equivalent means capable to resist lateral displacement. Manufactured post-to-beam connectors shall be sized for the post and beam sizes. All bolts shall have washers under the head and nut.

Exception: Where deck beams bear directly on footings in accordance with Section R507.8.1.

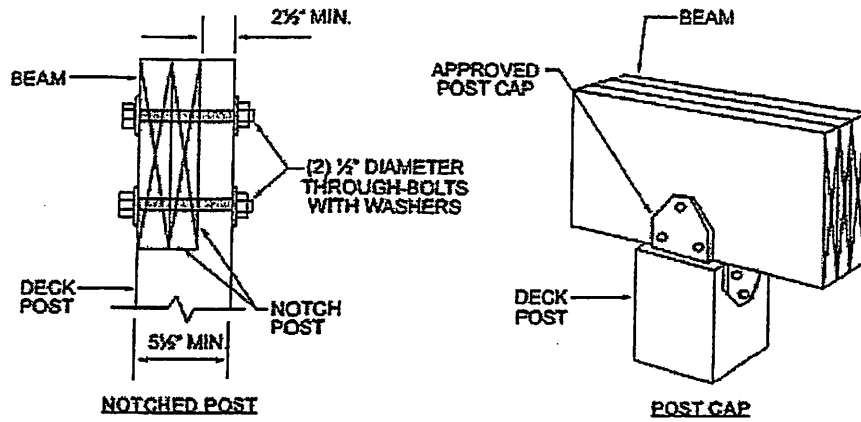

For SI: 1 inch = 25.4 mm.

**FIGURE R507.7.1
DECK BEAM TO DECK POST**

R507.8 Deck posts.

For single-level wood-framed decks with beams sized in accordance with Table R507.6, deck post size shall be in accordance with Table R507.8.

**TABLE R507.8
DECK POST HEIGHT^a**

DECK POST SIZE	MAXIMUM HEIGHT ^a
4 × 4	8'
4 × 6	8'
6 × 6	14'

For SI: 1 foot = 304.8 mm.

a. Measured to the underside of the beam.

R507.8.1 Deck post to deck footing.

Posts shall bear on footings in accordance with Section R403 and Figure R507.8.1. Posts shall be restrained to prevent lateral displacement at the bottom support. Such lateral restraint shall be provided by manufactured connectors installed in accordance with Section R507 and the manufacturers' instructions or a minimum post embedment of 12 inches (305 mm) in surrounding soils or concrete piers.

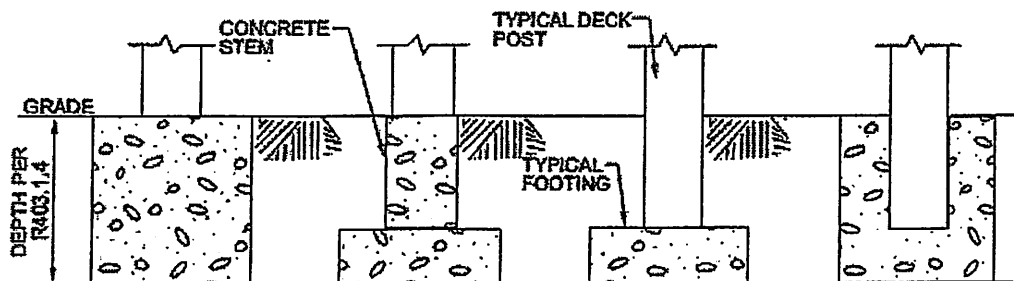

**FIGURE R507.8.1
TYPICAL DECK POSTS TO DECK FOOTINGS**

Douglas fir-larch^e, hem-fir^e, spruce-pine-fir^e,
redwood, western cedars, ponderosa pine^f, red pine^f

3 × 10 or 2 - 2 × 10	8-4	7-3	6-6	5- 11	5-6	5-1	4-8
3 × 12 or 2 - 2 × 12	9-8	8-5	7-6	6- 10	6-4	5- 11	5-7
4 × 6	6-5	5-6	4-11	4-6	4-2	3- 11	3-8
4 × 8	8-5	7-3	6-6	5- 11	5-6	5-2	4- 10
4 × 10	9-11	8-7	7-8	7-0	6-6	6-1	5-8
4 × 12	11-5	9- 11	8-10	8-1	7-6	7-0	6-7
3 - 2 × 6	7-4	6-8	6-0	5-6	5-1	4-9	4-6
3 - 2 × 8	9-8	8-6	7-7	6- 11	6-5	6-0	5-8
3 - 2 × 10	12-0	10- 5	9-4	8-6	7- 10	7-4	6- 11
3 - 2 × 12	13- 11	12- 1	10-9	9- 10	9-1	8-6	8-1

For SI: 1 inch = 25.4 mm, 1 foot = 304.8 mm, 1 pound per square foot = 0.0479 kPa, 1 pound = 0.454 kg.

- Ground snow load, live load = 40 psf, dead load = 10 psf, $L/\Delta = 360$ at main span, $L/\Delta = 180$ at cantilever with a 220-pound point load applied at the end.
- Beams supporting deck joists from one side only.
- No. 2 grade, wet service factor.
- Beam depth shall be greater than or equal to depth of joists with a flush beam condition.
- Includes incising factor.
- Northern species. Incising factor not included.

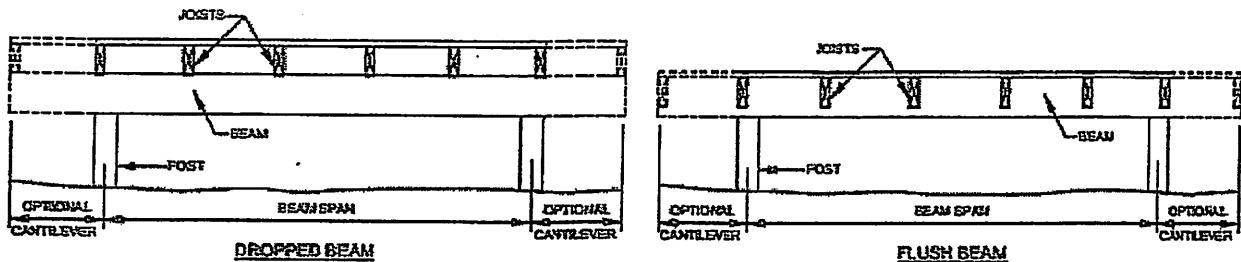

FIGURE R507.6
TYPICAL DECK BEAM SPANS

R507.7 Deck joist and deck beam bearing.

The ends of each joist and beam shall have not less than 1½ inches (38 mm) of bearing on wood or metal and not less than 3 inches (76 mm) on concrete or masonry for the entire width of the beam. Joist framing into the side of a ledger board or beam shall be supported by approved joist hangers. Joists bearing on a beam shall be connected to the beam to resist lateral displacement.

R507.7.1 Deck post to deck beam.

Deck beams shall be attached to deck posts in accordance with Figure R507.7.1 or by other equivalent means capable to resist lateral displacement. Manufactured post-to-beam connectors shall be sized for the post and beam sizes. All bolts shall have washers under the head and nut.

Exception: Where deck beams bear directly on footings in accordance with Section R507.8.1.

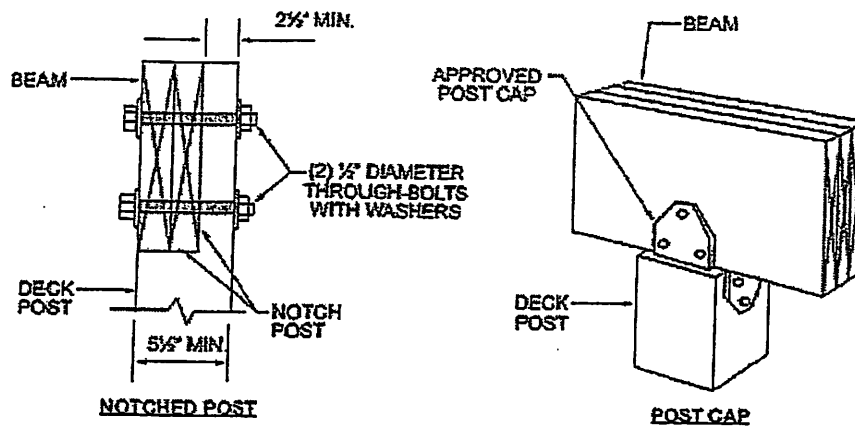

For SI: 1 inch = 25.4 mm.

FIGURE R507.7.1
DECK BEAM TO DECK POST

R507.8 Deck posts.

For single-level wood-framed decks with beams sized in accordance with Table R507.6, deck post size shall be in accordance with Table R507.8.

TABLE R507.8
DECK POST HEIGHT^a

DECK POST SIZE	MAXIMUM HEIGHT ^a
4 × 4	8'
4 × 6	8'
6 × 6	14'

For SI: 1 foot = 304.8 mm.

a. Measured to the underside of the beam.

R507.8.1 Deck post to deck footing.

Posts shall bear on footings in accordance with Section R403 and Figure R507.8.1. Posts shall be restrained to prevent lateral displacement at the bottom support. Such lateral restraint shall be provided by manufactured connectors installed in accordance with Section R507 and the manufacturers' instructions or a minimum post embedment of 12 inches (305 mm) in surrounding soils or concrete piers.

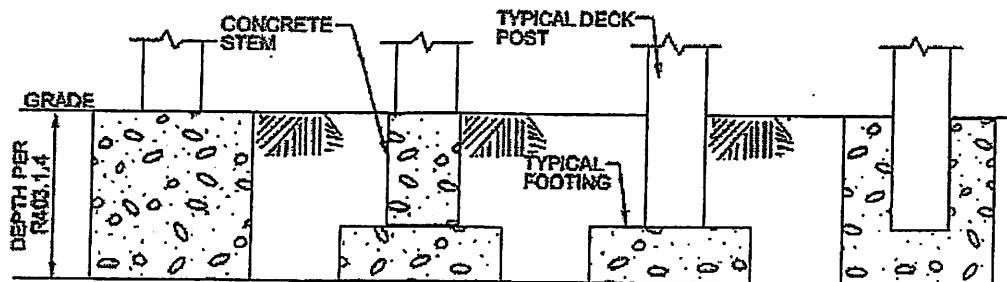

FIGURE R507.8.1
TYPICAL DECK POSTS TO DECK FOOTINGS