

Montalbano, Condon & Frank, P.C.

ATTORNEYS AND COUNSELORS AT LAW

67 North Main Street • New City, New York 10956-8070

PHONE (845) 634-7010 FAX (845) 634-8993

Richard H. Sarajian*
Alan G. Rosenblatt
Brian J. Quinn
John E. Finnegan
David Warren*
Charlotte G. Swift*
Lino J. Sciarretta*

*Kurt E. Johnson
Martin Butcher
**Andrew Ross
Rudolph O. Zodda, III

OF COUNSEL:
Anthony Montalbano
Thomas A. Condon
William Frank

*ADMITTED IN NY & NJ
**ADMITTED IN NY & MA

August 30, 2018

Via Federal Express

Hon. Rosanna Sfraga
Town Clerk
Town of Orangetown
26 W. Orangeburg Road
Orangeburg, NY 10962

RE: Town Code Chapter 41 – Watercourse Diversion Permit
27 Sunrise Lane, Pearl River, NY (the “Property”)
Kreiger Estate – Section 69.18, Block 3, Lot 43.2

Dear Town Clerk Sfraga:

We represent Steven Griffin in connection with the above-referenced matter. Enclosed are eight (8) sets of plans, pipe calculations, and check in the amount of \$100 payable to the Town of Orangetown for a watercourse diversion permit.

The Property, which is pending before the Planning Board, is for the construction of a single-family residence. In connection with the site plan approval, Griffin has been asked by the Town Highway Department and Department of Environmental Management and Engineering to relocate an existing 24-inch storm water pipe away from the proposed residence. To that end, Griffin proposes to install a new 36’ drainage pipe running approximately 92-feet into a RIPRAP outlet protection. This proposed pipe will be more than 15 feet away from the proposed residence. This new drainage system will eliminate an open ditch condition presently on the site.

We respectfully request that this item be placed on the Town Board agenda for consideration. Please let us know the date of that Town Board meeting. We thank you for your consideration and attention to this matter.

August 30, 2018
Page 2

Very truly yours,

MONTALBANO, CONDON & FRANK, P.C.

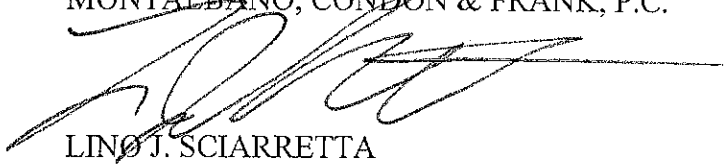

LINO J. SCIARRETTA

LS/br

Enclosures

cc: James Dean, Superintendent of Highways (w/ enclosures)
Joseph Moran, Commissioner DEME (w/ enclosures)
Robert Magrino, Town Attorney (w/o enclosures)

LOCAL LAW TO AMEND CHAPTER 26 OF THE TOWN CODE OF THE TOWN OF ORANGETOWN REGARDING PUBLIC ELECTRIC VEHICLE PARKING SPACES

BE IT ENACTED BY THE TOWN BOARD OF THE TOWN OF ORANGETOWN AS FOLLOWS:

The said section of the Code, Chapter 26, is amended as follows (Additions to the existing law are **Bold and underline**; Deletions are designated by ~~strikethrough~~):

Section 1.

§ 26-1. Definitions.

As used in this chapter, the following terms shall have the meanings indicated:

BATTERY ELECTRIC VEHICLE

Any vehicle that operates exclusively on electrical energy from an off-board source that is stored in the vehicle's battery(ies), and produces zero tailpipe emissions or pollution when stationary or operating.

CHARGING

When an electric vehicle is connected to electric vehicle supply equipment (or standard outlet) for the purpose of recharging motive batteries on board the electric vehicle.

ELECTRIC VEHICLE

Any motor vehicle that is registered with New York State Department of Motor Vehicles (DMV) and is authorized to operate on public and private highways, roads and streets, and operates, either partially or exclusively, on electrical energy from the grid, or an off-board source, that is stored on-board for motive purpose. "Electric vehicle" includes:

- (1) A battery electric vehicle;
- (2) A plug-in hybrid electric vehicle;
- (3) A neighborhood electric vehicle; and
- (4) A medium-speed electric vehicle.

ELECTRIC VEHICLE CHARGING STATION – PUBLIC USE

An area that is publicly owned and publicly available (e.g. parking spaces on a public street or municipal parking lot), that is served by electric vehicle supply equipment or battery charging station equipment that has as its primary purpose the transfer of electric energy (by conductive or inductive means) to a battery or other energy storage device in an electric vehicle.

ELECTRIC VEHICLE PARKING SPACE

Any marked parking space that is equipped with an Electric Vehicle Charging Station.

MEDIUM-SPEED ELECTRIC VEHICLE

A self-propelled electrically powered four-wheeled motor vehicle, equipped with a roll cage or crush-proof body design, whose speed attainable in one mile is more than 25 miles per hour but not more than 35 miles per hour and otherwise meets or exceeds the Federal regulations set forth in 49 CFR Section 571.500.

NEIGHBORHOOD ELECTRIC VEHICLE

A self-propelled, electrically powered four-wheeled motor vehicle whose speed attainable in one mile is more than 20 miles per hour and not more than 25 miles per hour and conforms to Federal regulations set forth in 49 CFR Section 571.500.

PLUG-IN HYBRID ELECTRIC VEHICLE (PHEV)

An electric vehicle that (1) contains an internal combustion engine and also allows power to be delivered to drive wheels by an electric motor; (2) charges its battery primarily by connecting to the grid or other off-board electrical source; (3) may additionally be able to sustain battery charge using an on-board internal combustion-driven generator; and (4) has electricity-powered travel capability.

§ 26-4. Spaces designated.

- G. Certain parking spaces on public streets or in Town owned municipal parking lots shall be designated as Electric Vehicle Parking Spaces by the Town. The Town Board shall establish and may amend the fees, limitations of time and occupancy for the use of the Electric Vehicle Parking Spaces and Electric Vehicle Charging Stations-Public Use, by Town Board Resolution. Notwithstanding anything to the contrary contained within this Chapter regarding parking meters, fees shall be based upon kilowatt hours per charge plus an applicable surcharge, in addition to a fee for the use of the parking space as determined by the Town Board.

§ 26-15. Violations and penalties; removal of illegally parked vehicles.

D. In addition to any other penalties set forth in this Chapter, vehicles parked in an Electric Vehicle Parking Space in violation of this section or as posted with signage installed in accordance with the fees, limitations of time and occupancy established in accordance with this section, may be towed. Any costs associated with towing and storage of a vehicle that is towed pursuant to this section shall be at the vehicle owner's expense.

Section 2. Severability Clause

The invalidity of any word, section, clause, paragraph, sentence, part or provision of this local law shall not affect the validity of any other part of this local law that can be given effect without such invalid parts.

Section 3. Effective Date.

This Local Law shall become effective immediately upon being filed with the Secretary of State.

**LOCAL LAW NO. __ OF 2018, AMENDING CHAPTER 43 OF THE TOWN
CODE ARTICLE V AND ARTICLE XI TO PROVIDE FOR THE
DEFINITION AND REGULATION OF TEMPORARY STORAGE
CONTAINERS (PODS)**

BE IT ENACTED BY THE TOWN BOARD OF THE TOWN OF
ORANGETOWN AS FOLLOWS:

As amended, Additions are underlined, ~~Deletions are stricken~~. The said section of
the Code is amended as follows:

Section 1.

A) ARTICLE V

Section 5.2 Exceptions to bulk regulations

5.229-A

1. Temporary portable storage containers shall be permitted under the provisions of this section. Not more than one container shall be allowed per residential lot. Enclosed containers shall not exceed 128 square feet and eight feet in height. The temporary storage container must be a minimum of 5 feet from any side or rear yard property line; in no instance shall the container be placed in a required front yard, unless in a permitted driveway, nor shall it be placed in a public right-of-way or easement.

2. A permit is required from the Building Inspector for the placement of a temporary portable storage container after being in place for more than 30 days in any 180 day period. The permit shall authorize such container to remain for a period not to exceed 180 days thereafter. Upon application made within 15 days of the expiration of the permit, the Building Inspector may grant a permit to extend the initial 180 day time period for an additional 180 days, provided the applicant has a valid and existing building permit for construction activities at the property, or applies for such a building permit simultaneously with the application for an extension.

3. No permit shall be issued for another temporary storage container for the same residential lot until two years from the issuance of a previously issued permit, except if the ownership of the lot changes.

4. The permit must be displayed in a conspicuous place on the temporary portable storage container.

5. Failure to obtain a permit and/or any container that is situated in violation of an issued permit or this section shall constitute a violation of the zoning code, subject to penalty as per §10.6 of the code. The fee for the permit for the temporary storage container shall be established as per Town Board resolution.

B) ARTICLE XI

Section 11.2 Definitions:

TEMPORARY STORAGE CONTAINER

Any portable container, receptacle, or device of a type commonly used for the temporary storage of personal property and other matter. The term shall include, but not be limited to, portable on-demand storage units (PODS).

Section 2. Severability Clause

The invalidity of any word, section, clause, paragraph, sentence, part or provision of this local law shall not affect the validity of any other part of this local law that can be given effect without such invalid parts.

Section 3. Effective Date.

This Local Law shall become effective immediately upon being filed with the Secretary of State.

Orangetown Housing Authority Board Meeting Minutes – June 27, 2018

Attendance:

Bob Nelan – Chairperson

Walter Wettje - Treasurer

Jack O'Connor – Vice Chairman

Patricia Brown – Tenant Representative

Sharon Ogden - Tenant Representative

Joseph Jukic - Secretary

Mamie Freeman- ARCO Representative

Chairman Nelan Opened the Meeting

Pledge of Allegiance

Reading and Approval of previous: Waived

Chairman's Report: None

Board Members Comments:

Walter Wettje introduces meeting topics to be covered

Representative from Johnson Controls summarize upgrades and updates of recently installed and tested fire alarm system project. Answer questions from board and tenants.

Presentation from Orangetown Police Department Detective Mahar addressing various safeguards to avoid being the victim of prevalent scams targeting seniors. Answer questions from board and tenants.

Presentation from Neil O'Sullivan, CPA addressing OHA Financial statements and overall financial condition. Mr. O'Sullivan expresses overall satisfaction with financial profile of OHA. Suggests an increase to \$1,000 for capital asset valuation minimum.

Tenant Comments:

Requests to repaint parking lines

Confirmation of pet policy after concerns expressed regarding tenants maintaining pets outside of acceptable guidelines. Vice Chairman O'Connor reiterates guidelines for service pets only.

Expressed concerns regarding availability of parking and the potential use of parking permits.

Treasure Wettje suggests the contracting of a security guard to maintain parking lot for a 3 month period test run. Suggests a Mon-Fri 5PM-12AM and Sat-Sun 10AM-4PM shift as that is when volume is highest.

Tenants express concerns regarding certain exterior lights not functioning and Ms Freeman to discuss with Superintendent.

Board expresses concerns regarding Superintendent's employment status and whether Supt. is employee of OHA, Town or Management company(ARCO). Ms. Freeman explains that Super was originally employed by OHA but is supervised by ARCO and is on the payroll of ARCO.

Secretary Jukic suggests having Supt present at certain board meetings to address some of the building management concerns expressed by tenants and board members. Superintendent has not historically been in attendance at board meetings.

Motion

Motion to increase capital asset minimum to \$1,000 as suggested by Mr. O'Sullivan - Motion passed 6-0

Motion to open up the position of Superintendent to new candidates – Motion passed 6-0

Motion to decrease tenant board member rent by \$50. Board members Ogden and Brown express resistance to this motion – Motion passed 4-2

Motion to contract Treasure Wettje as Project Manager for capital improvement projects at an hourly rate of \$50 – Motion Passed

(It has since been brought to our attention that these last two motions are likely prohibited by the Orangetown Code of Ethics, please see meeting minutes addendum below.

Board elections

Bob Nelan – Unanimously re-elected Board Chairman

Jack O'Connor – Unanimously re-elected Board Vice Chairman

Walter Wettje - Unanimously re-elected Treasure

Joe Jukic - Unanimously re-elected Secretary

Sharon Ogden – Runs unopposed and is re-elected board tenant representative.

Chairman Nelan motions to close the meeting, second by Vice Chairman O'Connor

Note: Bills and claims were approved by the Board in an Executive session.

Addendum Below – August 3, 2018

Dear OHA Members,

I would like to thank you for the confidence you showed in me by voting to pay me for the service of project manager to ensure that the Capital Program we established through our new bond was managed professionally.

Unfortunately I have to decline this position. I have been advised by Counsel that this position while I remain a member of this board would be a conflict of interest. Also, if I was to resign my position on the OHA Board to manage the upcoming Capital Projects, I would have to wait two years before I would be able to fill that position.

All of this is based on both the Code of Ethics Policy for the Town of Orangetown and also NYS Public Housing Law.

NYS Public Housing Law states(PBG151) : Contracts of an authority for demolition, excavation, construction, alteration, renovation or purchase of materials or supplies shall be in such form and contain such combination of work or trades and such terms and provisions as may be deemed advisable by the authority. All such contracts, except for purchases of materials or supplies, in excess of fifty thousand shall be made on sealed bids, in compliance with a public notice advertised at least once, not less than twenty days before the date set for the receipt of bids.

NYS Public Housing Law states (PBG36) : No member or employee of an authority shall acquire any interest direct or indirect in a project nor shall they have any interest direct or indirect in any contract or proposed contract or services to be furnished or used in connection with any project.

What this means to the OHA Board.

1. I cannot accept this position.
2. It also can be interpreted that we cannot allow a \$50 discount in rent for the two resident board members. The Orangetown Code of Ethics (circa 1976) basically prohibits the compensation or compensatory position of those that serve as an appointment to a voluntary position. For example our two resident members or other Town voluntary appointments that receive compensation whether through payment, or, discount on a service that has direct influence in Town interests whether by the Town or an outside concern.
3. We need to research and find an Attorney to represent the OHA Board on legal matters.
4. We will possibly need to bid out the Architectural work that Jane Slavin did in the past.

My recommendation is that the Board consider meeting and research the retaining of an Attorney so that the board has a legal opinion on the work the board is attempting to do.

I recommend we do not enter into a contract with John Fellenzer Architects for starting the work on the Capital Program until we get a formal opinion in writing from an Attorney we have on retainer. The OHA Board is best protected by having it stated by Counsel we do not have to bid the Architectural work as a service.

Joe Jukic, please attach this email to the minutes of June 27th 2018 where it was voted to compensate me for project management work.

Regards,

Walter Wettje - OHA Treasurer

ACKNOWLEDGEMENT

JOHN ANGELIS

accuratehome@aol.com

LOWER HUDSON VALLEY
PROPERTY MANAGEMENT, INC

ONE CRANE PLACE - SUFFERN - NEW YORK 10901

STATE OF NEW YORK)

SS.

COUNTY OF ROCKLAND)

On the 4th day of September, 2018, before me, the undersigned, a Notary Public in and for said state, personally appeared **CHRISTOPHER E. DAY**, personally known to me or proved to me on the basis of satisfactory evidence to be the individual whose name is subscribed to the within instrument and acknowledged to me that he executed the same in his capacity, and that by his signature on the instrument, the individual, or the person upon behalf of which individual acted, executed the instrument.

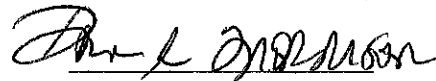

Notary Public

DONNA A. MORRISON

Notary Public, State of New York

No. 01MO5081099

Qualified in Rockland County

Commission Expires June 30, 2019

STATE OF NEW YORK)

SS.

COUNTY OF ROCKLAND)

On the 18th day of August, 2018, before me, the undersigned, a Notary Public in and for said state, personally appeared JOHN ANGELIS, personally known to me or proved to me on the basis of satisfactory evidence to be the individual whose name is subscribed to the within instrument and acknowledged to me that he executed the same in his capacity, and that by his signature on the instrument, the individual, or the person upon behalf of which individual acted, executed the instrument.

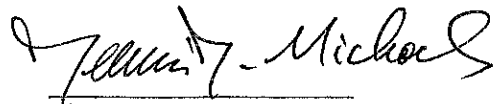

Notary Public

DENNIS D. MICHAELS

Notary Public, State of New York

No. 02MI4996201

Qualified in Rockland County

Commission Expires May 11, 2022

**THE TOWN OF ORANGETOWN
ADOPT-A-SPOT AGREEMENT
(FOR COMMERCIAL SPONSOR)**

The Town of Orangetown, having offices at 26 W. Orangeburg Road, Orangeburg, New York, 10962, hereafter called the "Town" and the organization known as the following and using the mailing address of:

LOWER HUDSON DAILEY PROPERTY MANAGEMENT INC
CRANE PL, SUFFERN NY 10901

Hereafter called the "ADOPTTEE", recognize the need for and desirability of a more attractive and litter-free Town, hereafter known as the "SPOT", and are entering into this Agreement to enable the ADOPTTEE to contribute toward the effort of maintaining the appearance of the SPOT. By signature below, the ADOPTTEE acknowledges the hazardous nature of the activity and agrees to the following terms and conditions:

1. No participants' vehicles may be parked on the travel lanes or shoulders of a highway while engaged in clean-up activities/improvements without prior approval from the Town of Orangetown.
2. Activities permitted are of a maintenance nature, including, but not limited to litter pick-up, brush control and cutting, tree trimming and planting, and maintaining approved vegetation, except as modified by the Town Representative.
3. The ADOPTTEE will organize and supervise all activities.
4. The ADOPTTEE will organize and conduct a "safety briefing". Each day that that work is done in the adopted area, a designated safety person must review the safety checklist and have participants sign the safety signature sheet. The designated safety person's sole responsibility must be assuring the safety of the workers and the traveling public during maintenance activities at the SPOT. If requested, the Town will provide a representative to present the safety the safety briefing for the first meeting, and after that a designated person from the ADOPTTEE shall conduct such briefings.
5. All participants must attend the safety briefing before participating in the field activity. The briefings should be held on-site to ensure that all participants are in attendance.
6. The ADOPTTEE will provide for disposal of collected waste from location specified in the permit.
7. The ADOPTTEE will conduct activities at a frequency which will enhance the attainment of the goal, which is to provide a park-like appearance within the adopted SPOT and fully comply with the above-mentioned "safety checklist." Except as modified by the Town

Representative, minimum frequency of pick-up within the SPOT is four (4) times a year with the first pickup occurring in the April-May "Spring Clean-Up" time period.

8. The ADOPTEE will provide seventy-two (72) hour notice to the Town of Orangetown Supervisor's office as to when they are going to do any work on the SPOT. The ADOPTEE will dispose of any and all debris that they collect, as per the instructions of the Town.
9. The ADOPTEE participant will sign and date the "Adopt-A-Spot General Release" protecting the Town, to be kept on file in the Town Supervisor's Office for the duration of the time period designated in the application.
10. The Town will publicize the execution of this agreement and will highlight it at various periods thereafter.
11. The Town will furnish and erect Adopt-A-Spot signs at the adopted SPOT.
12. The Town will continue to apply it's assets in the maintenance of the SPOT.
13. This agreement shall be for a two year period commencing on 10/1, 2019, and terminating at 12:01 a.m. on 9/30, 2020.

Notwithstanding any other provision of this agreement, if in the sole judgment of the Town, it is determined that the ADOPTEE is not meeting the terms and conditions of this Agreement, upon 30 days notice, or summarily if based upon unsafe activity, the Town may terminate this agreement as otherwise provided herein, and take such other action as it deems appropriate.

The Town recognizes the ADOPTEE as the adopting organization for the SPOT, and the ADOPTEE accept the responsibility of maintaining the attractive appearance of the adopted facility and of promoting a litter free environment in the community for the term of this agreement.

The relationship of the ADOPTEE to the Town arising out of this agreement shall be that of an independent contractor. Any and all members or employees of the ADOPTEE under this agreement, shall be considered agents of the ADOPTEE, and all claims arising under the workers compensation law of the State of New York on behalf of said employees while so engaged, in any act or omission on the part of the ADOPTEE employees while so engaged in any of the work or services provided to rendered herein, shall be the sole obligation and responsibility of the ADOPTEE. The ADOPTEE shall secure worker's compensation insurance, for the benefit of, and keep insured during the life of this agreement, such ADOPTEE employees engaged therein, as are required to be insured by the provisions of the worker's compensation law.

The ADOPTEE will, at its own expense and during the term of the Adopt-A-Spot program, maintain comprehensive general liability insurance in the amount of one million dollars combined single limit name the Town of Orangetown as an additional named insured.

Said policy shall expressly require 30 days written notice to the Town of Orangetown of the cancellation or material alteration of said policy and the certificate of insurance shall so provide.

The ADOPTEE hereby agrees to defend, indemnify, save and hold harmless the Town of Orangetown, and all other agents and employees from any and all claims, demands, actions, or cause of action or whatsoever nature or character arising out of or by reason of the execution or performance of work and services provided for herein, including all reasonable expenses incurred by the Town of Orangetown from said claims and further agrees to defend at its own cost and expense any action or proceed commencement for the purpose of asserting any claim whatsoever character arising hereunder.

LHOPM INC
NAME OF ADOPTEE

(John Angelis)
ADOPTEE PRESIDENT

John Angelis
President (Name) (Please Print)

Christopher E. Day
Town Representative
Supervisor, Town of Orangetown

(845) 548-5100
Department Representative
Daytime Telephone Number

**TOWN OF ORANGETOWN
ADOPT-A-SPOT
DAILY WORK PARTY SIGN OFF FORM**

Work Date: _____

Club Name: _____

Club Safety Representative: _____

- No work will begin until ALL signs and cones are in place.
- No crossing of pavement when traffic would have to slow down or accommodate crossing.
- Do not park on the Right-of-Way.
- All workers will wear a hard hat, proper footwear, long pants, and a safety vest or orange shirt.
- Proper eye and hearing protection shall be worn when appropriate.
- The Right-of-Way must be cleared of litter ahead of any mowing or mechanical brush operation.
- When mowing adjacent to pavement, grass or debris shall not be thrown on pavement or into traffic.
- When working close to the road way, always have one person watching traffic; work shall progress facing traffic.
- No work shall be done on pavement or shoulders.
- Stop working in inclement weather.
- Do not remove hazardous substances-**NOTIFY HIGHWAY DEPARTMENT.**

REMEMBER-You are working in a potentially dangerous environment.

I have read and will follow the above Safety Rules:

**TOWN OF ORANGETOWN
ADOPT-A-SPOT
GENERAL RELEASE**

KNOW ALL MEN BY THESE PRESENTS, that I,

John Angelis (Participant's Name)

1 CRANE PL (Street Address)

SUFFERN NY 10901 (Town, State, Zip)

in consideration of \$1.00 payment which is hereby waived, and other good and valuable consideration given by the Town of Orangetown, for myself and my representative in any capacity, release and discharge the Town of Orangetown, its officers and employees their representatives, successors and assigns, from all causes of action, controversies, claims, judgments or liabilities I may now have or may hereafter have against said Town and its officers and employees arising out of my participation in the Adopt-A-Spot Program developed by the Town of Orangetown Town Board pursuant to Resolution _____ of _____.

IN WITNESS WHEREOF, I have executed this release on 8/20/19 (Date).

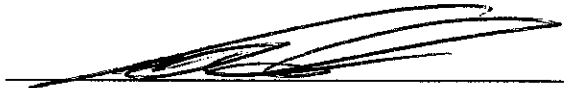

(Signature)

John Angelis

(Print Name of Signatory)

(Please submit a copy for each member)

TOWN OF ORANGETOWN
ADOPT-A-SPOT
DATA SHEET

ADOPTEE Name: Lower Hudson Valley Property Management Inc

Address: 1 CARNE PL SUFFW NY 10901

1st Contact Person: John Angeli

Name: ~~_____~~

Name: ~~_____~~

Address: ~~_____~~

Address: ~~_____~~

Phone:

Home () _____

Home () ~~_____~~

Work (845) 590-6927

Work () ~~_____~~

SPOT LOCATION: (Street name, nearest cross streets, house numbers (if known)
closest landmarks, if any)

PEARL RIVER TRAIN STATION

PEARL RIVER POLICE BOOTH

PEARL RIVER POST OFFICE FLAG POLE

Number of ADOPTEE Participants: 1

Dates of Commitment: 6/10/1/2018 to 12-1-2018

Attach ADOPTEE Charter (if Available)

**TOWN OF ORANGETOWN
ADOPT-A-SPOT
PROTOCOL
(FOR COMMERCIAL SPONSOR)**

1. Volunteer ADOPT-EEs or organization shall apply to the Town of Orangetown for participation in the ADOPT-A-Spot Program by submitting a completed ADOPT-A-SPOT Data Sheet.
2. If the proposed SPOT is deemed appropriate for the Program by the Town Supervisor of Orangetown, all acceptable applicants shall be referred to the Town Board for screening and approval for participation in the Town of Orangetown ADOPT-A-SPOT Program.
3. Upon screening and approving said applicants, the Town of Orangetown shall forward copies of:
 - a. A Town of Orangetown Adopt-A-Spot Agreement indicating the applicant ADOPT-EE has been screened and approved.
 - b. Adopt-A-Spot Program general releases signed by each ADOPT-EE member participating in the program.
4. The Supervisor of the Town of Orangetown shall review the Agreements, and upon approval of same forward the Agreements to the Town Board for official ratification.
5. The Adopt-A-Spot Program will be administered by the Town of Orangetown after final ratification of agreements by the Town Board.

RECEIVED

AUG 13 2018

TOWN OF ORANGETOWN
SPECIAL USE PERMIT FOR USE OF TOWN PROPERTY/ITEMS

PERMIT # 18-SP-47

TOWN OF ORANGETOWN
HIGHWAY DEPARTMENT

RECEIVED
AUG 21 2018
Orangetown Police Department

EVENT NAME: Velocity Ride to End Cancer

APPLICANT NAME: Eventage Event Production

ADDRESS: 18 South Orange Ave, 3rd Fl. South Orange, NJ 07079

PHONE #: 973-530-3900 x 123 CELL # 253-740-4126 FAX # 973-530-3901

CHECK ONE: PARADE RACE/RUN/WALK OTHER Bike Ride

The above event will be held on Sunday, October 7 from 10:30am to 1:00pm RAIN DATE: N/A

Location of event: see attached route map for roadway request

Sponsored by: benefitting Columbia University's Herbert Irving Medical Center Telephone #: _____

Address: _____

Estimated # of persons participating in event: 400 vehicles 10 (route support vehicles)

Person (s) responsible for restoring property to its original condition: Name-Address-Phone #: see above applicant info

Signature of Applicant: Jena McLaughlin Date: 8/3/2018

GENERAL INFORMATION REQUIRED: (HIGHWAY/PARKS/POLICE)

Letter of Request to Town Board requesting aid for event - Received On: 8-13-18

Certificate of Insurance - Received On: 8-13-18

FOR HIGHWAY DEPARTMENT USE ONLY:

Road Closure Permit: Y/N - Received On: X

Rockland County Highway Dept. Permit: Y/N - Received On: 8-15-18

NYS DOT Permit: Y/N - Received On: X

Route/Map/Parking Plan: Y/N - Received On: 8-13-18

RFS #: X BARRICADES: Y/N CONES: Y/N TRASH BARRELS: Y/N OTHER: X

APPROVED: [Signature] DATE: 8.17.18
Superintendent of Highways

RECEIVED

FOR PARKS & RECREATION DEPARTMENT USE ONLY:

Show Mobile: Y/N - Application Required: X Fee Paid - Amount/Check # _____

Port-o-Sans: Y/N: X Other: _____

APPROVED: [Signature] DATE: 8/21/18
Acting Superintendent of Parks & Recreation

AUG 22 2018

TOWN OF ORANGETOWN
HIGHWAY DEPARTMENT

FOR POLICE DEPARTMENT USE ONLY:

Police Detail: Y/N: X Items: _____

APPROVED: [Signature] DATE: 8/21/18
Chief of Police

** Please return to the Highway Department to be placed on the Town Board Workshop **

Workshop Agenda Date: 9.4.18 Approved On: _____ TBR #: _____

RECEIVED

JAMES J. DEAN
Superintendent of Highways
Roadmaster II

AUG 13 2018

HIGHWAY DEPARTMENT
TOWN OF ORANGETOWN

119 Route 303 • Orangeburg, NY 10962
(845) 359-6500 • Fax (845) 359-6062
E-mail - highwaydept@orangetown.com

Orangetown Representative
R.C. Soil & Water Conservation Dist.-Chairman
Member:
American Public Works Association NY Metro Chapter
NYS Association of Town Superintendents of Highways
Hwy. Superintendents' Association of Rockland County

TOWN OF ORANGETOWN
HIGHWAY DEPARTMENT



USE

ROAD CLOSING PERMIT APPLICATION
Section 139 Highway Law

NAME Jena Mc Laughlin DATE 8-13-18
COMPANY Eventage Event Production
ADDRESS 18 S. Orange Avenue S. Orange, NJ 07079
TELEPHONE 973-530-3900 x 123

(INCLUDE 24 HOUR EMERGENCY NUMBERS)

ABOVE MENTIONED PARTY REQUESTS PERMISSION TO ~~CLOSE~~ ^{USE} ~~CLOSING~~

S. Pascack Road, Crooked Hill Rd, Main St, E. Wash. Ave,
(Address number and name of road) N. Henry St, Middlebrook Rd, Old Middlebrook Rd,
Hunt Rd + Olympic Drive, Coordinate Dr.

(Intersecting streets and/or description of exact location)

REASON FOR CLOSING ^{USE} Velocity Ride to end cancer -

DATE OF CLOSING ^{USE} 10-7-18 RAIN DATE n/a

TIME ROAD WILL BE CLOSED ^{USE} 10:30 am - 1 pm

WILL ROAD BE OPEN TO LOCAL TRAFFIC? Yes

WILL ROAD BE OPEN TO EMERGENCY VEHICLES? Yes

PLEASE PROVIDE A DETAILED MAP AND DESCRIPTION OF DETOUR IF TRAVEL WILL BE RESTRICTED.

PRELIMINARY APPROVAL [Signature] DATE 8-17-18
JAMES J. DEAN
SUPERINTENDENT OF HIGHWAYS

This permit application will be forwarded to the Rockland County Superintendent of Highways, County of Rockland, 23 New Hempstead Road, New City, NY, 10956. You will receive written confirmation from that office.

8-13-02bjd

HAMLETS: PEARL RIVER • BLAUVELT • ORANGETOWN • TAPPAN • SPARKILL • PALISADES • UPPER GRANDVIEW



CLEAN STREETS = CLEAN STREAMS



RECEIVED

Ed Day, Rockland County Executive

AUG 15 2018

TOWN OF ORANGETOWN
HIGHWAY DEPARTMENT

HIGHWAY DEPARTMENT

23 New Hempstead Road
New City, New York 10956
Phone: (845) 638-5060 Fax: (845) 638-5037
Email: highway@co.rockland.ny.usCharles H. "Skip" Vezzetti
Superintendent of HighwaysPERMIT AND NOTICE TO **Use** A ROADTo the Town Clerk of *Orangetown* in Rockland County:

This is to certify that the Superintendent of Highways of Rockland County has been requested by

Columbia Presbyterian Hospital Cancer Div. c/o Velocity Eventage (Jenna McLaughlin @ 973-530-3900 x123)"ROADS REMAIN OPEN TO TRAFFIC. THIS IS FOR THE USE OF THE ROADS"To *Use* a section of Highway in the Town of *Orangetown* Rockland County, known asPomona Road, Lime Kiln Road, Spook Rock Road, Airmont Road, Montebello Road, Hemion Road, Viola Road,
Grandview Ave., Pascack Road, Middletown Road, Veterans Memorial Drive, Orangeburg Road, Blaisdell RoadThe portion of highway will be *Used* under Highway Law on 10/7/18, 9 am---- 1 pm SundayFor the purpose of CANCER Research Awareness Fundraiser Bike RideThis activity can not be properly conducted unless the portion described above is *Used* during the time such activity is in progress.To the Town Highway Superintendent of *Orangetown* in Rockland County:

A certificate of which the foregoing is a copy having been executed by me under the authority conferred by Section 104 of the Highway Law and filed in the office of the Town Clerk in *Orangetown* on the 14th Day of August 2018, you are hereby notified that I have authorized the *Use* of the above described section of highway. The applicant must provide a detour for traffic during the time the road is *Used* and notify police, fire, ambulance, school districts and public transportation prior to *Using* of the roadway. The applicant must provide the necessary signs, barricades, lights, flagmen, etc. and make every effort to cooperate with the traveling public. Keep fire, police, ambulance, public transportation and school entities informed as to daily activities, concerning the *Use*.

Dated this 14th August 2018

Rockland County Superintendent of Highways

8/14/18

RECEIVED

AUG 13 2018

TOWN OF ORANGETOWN
HIGHWAY DEPARTMENT



A Bicycling Fundraiser Benefitting



COLUMBIA UNIVERSITY
MEDICAL CENTER

Herbert Irving Comprehensive Cancer Center

Road Use Only

Town of Orangetown
Department of Highways
119 Route 303
Orangeburg, NY 10962

To whom it may concern:

I am writing to request use of Pearl River roads for Velocity, Columbia's Ride to End Cancer, benefiting Columbia University Medical Center and the Herbert Irving Comprehensive Cancer Center on Sunday, October 7, 2018.

Enclosed you will find more detailed information about the event, route maps showing the roads we seek to use as well as turn by turn route cues. In addition, I am including a certificate of insurance naming the Town of Orangetown as additionally insured.

Should you have any questions, I can best be reached on my cell phone at 253-740-4126 or via email at jmclaughlin@eventage.net.

Thank you for your consideration.

Best,

Jena McLaughlin
Velocity Ride Director



CERTIFICATE OF LIABILITY INSURANCE

DATE (MM/DD/YYYY)
08/10/2018

THIS CERTIFICATE IS ISSUED AS A MATTER OF INFORMATION ONLY AND CONFERS NO RIGHTS UPON THE CERTIFICATE HOLDER. THIS CERTIFICATE DOES NOT AFFIRMATIVELY OR NEGATIVELY AMEND, EXTEND OR ALTER THE COVERAGE AFFORDED BY THE POLICIES BELOW. THIS CERTIFICATE OF INSURANCE DOES NOT CONSTITUTE A CONTRACT BETWEEN THE ISSUING INSURER(S), AUTHORIZED REPRESENTATIVE OR PRODUCER, AND THE CERTIFICATE HOLDER.

IMPORTANT: If the certificate holder is an ADDITIONAL INSURED, the policy(ies) must have ADDITIONAL INSURED provisions or be endorsed. If SUBROGATION IS WAIVED, subject to the terms and conditions of the policy, certain policies may require an endorsement. A statement on this certificate does not confer rights to the certificate holder in lieu of such endorsement(s).

PRODUCER
Marsh USA Inc.
1717 Arch Street
Philadelphia, PA 19103-2797

RECEIVED

AUG 13 2018

CONTACT NAME:		
PHONE (A/C, No, Ext):	FAX (A/C, No):	
E-MAIL ADDRESS:		
INSURER(S) AFFORDING COVERAGE		NAIC #
INSURER A : Pinnacle Consortium of Higher Ed VT RRRG		11980
INSURER B : N/A		N/A
INSURER C : N/A		N/A
INSURER D : N/A		N/A
INSURER E : N/A		N/A
INSURER F : N/A		N/A

J09254-COLUM-No WC-18-19

INSURED
THE TRUSTEES OF COLUMBIA UNIVERSITY
IN THE CITY OF NEW YORK
ATTN: STEVE LAWRENCE
615 WEST 131ST STREET, 3RD FLOOR
NEW YORK, NY 10027

TOWN OF ORANGETOWN
HIGHWAY DEPARTMENT

COVERAGES

CERTIFICATE NUMBER:

CLE-006314713-02

REVISION NUMBER: 1

THIS IS TO CERTIFY THAT THE POLICIES OF INSURANCE LISTED BELOW HAVE BEEN ISSUED TO THE INSURED NAMED ABOVE FOR THE POLICY PERIOD INDICATED. NOTWITHSTANDING ANY REQUIREMENT, TERM OR CONDITION OF ANY CONTRACT OR OTHER DOCUMENT WITH RESPECT TO WHICH THIS CERTIFICATE MAY BE ISSUED OR MAY PERTAIN, THE INSURANCE AFFORDED BY THE POLICIES DESCRIBED HEREIN IS SUBJECT TO ALL THE TERMS, EXCLUSIONS AND CONDITIONS OF SUCH POLICIES. LIMITS SHOWN MAY HAVE BEEN REDUCED BY PAID CLAIMS.

INSR LTR	TYPE OF INSURANCE	ADDL INSD	SUBR WVD	POLICY NUMBER	POLICY EFF (MM/DD/YYYY)	POLICY EXP (MM/DD/YYYY)	LIMITS
A	<input checked="" type="checkbox"/> COMMERCIAL GENERAL LIABILITY <input type="checkbox"/> CLAIMS-MADE <input checked="" type="checkbox"/> OCCUR GEN'L AGGREGATE LIMIT APPLIES PER: <input checked="" type="checkbox"/> POLICY <input type="checkbox"/> PRO-JECT <input type="checkbox"/> LOC OTHER:			PCHE2018-02	07/01/2018	07/01/2019	EACH OCCURRENCE \$ 2,000,000 DAMAGE TO RENTED PREMISES (Ea occurrence) \$ 2,000,000 MED EXP (Any one person) \$ 2,500 PERSONAL & ADV INJURY \$ 2,000,000 GENERAL AGGREGATE \$ 5,000,000 PRODUCTS - COMP/OP AGG \$ 2,000,000
	AUTOMOBILE LIABILITY <input type="checkbox"/> ANY AUTO <input type="checkbox"/> OWNED AUTOS ONLY <input type="checkbox"/> SCHEDULED AUTOS <input type="checkbox"/> NON-OWNED AUTOS ONLY <input type="checkbox"/> HIRED AUTOS ONLY						COMBINED SINGLE LIMIT (Ea accident) \$ BODILY INJURY (Per person) \$ BODILY INJURY (Per accident) \$ PROPERTY DAMAGE (Per accident) \$
	UMBRELLA LIAB <input type="checkbox"/> OCCUR EXCESS LIAB <input type="checkbox"/> CLAIMS-MADE DED <input type="checkbox"/> RETENTION \$						EACH OCCURRENCE \$ AGGREGATE \$
	WORKERS COMPENSATION AND EMPLOYERS' LIABILITY ANY PROPRIETOR/PARTNER/EXECUTIVE OFFICER/MEMBER EXCLUDED? <input type="checkbox"/> Y <input checked="" type="checkbox"/> N (Mandatory in NH) If yes, describe under DESCRIPTION OF OPERATIONS below						PER STATUTE <input type="checkbox"/> OTH-ER <input type="checkbox"/> E.L. EACH ACCIDENT \$ E.L. DISEASE - EA EMPLOYEE \$ E.L. DISEASE - POLICY LIMIT \$

DESCRIPTION OF OPERATIONS / LOCATIONS / VEHICLES (ACORD 101, Additional Remarks Schedule, may be attached if more space is required)
The Town of Orangetown is recognized as additionally insure with regard to Velocity, Columbia's Ride to End Cancer on Sunday, October 7, 2018.

CERTIFICATE HOLDER

CANCELLATION

Town of Orangetown
26 W Orangeburg Rd
Orangeburg, NY 10962

SHOULD ANY OF THE ABOVE DESCRIBED POLICIES BE CANCELLED BEFORE THE EXPIRATION DATE THEREOF, NOTICE WILL BE DELIVERED IN ACCORDANCE WITH THE POLICY PROVISIONS.

AUTHORIZED REPRESENTATIVE
of Marsh USA Inc.
Manashi Mukherjee *Manashi Mukherjee*

© 1988-2016 ACORD CORPORATION. All rights reserved.

Pearl River / Chesnut Ridge
10:30am - 1:00pm



62.5/45 mile riders (approx 275)

25 mile riders (approx 100)

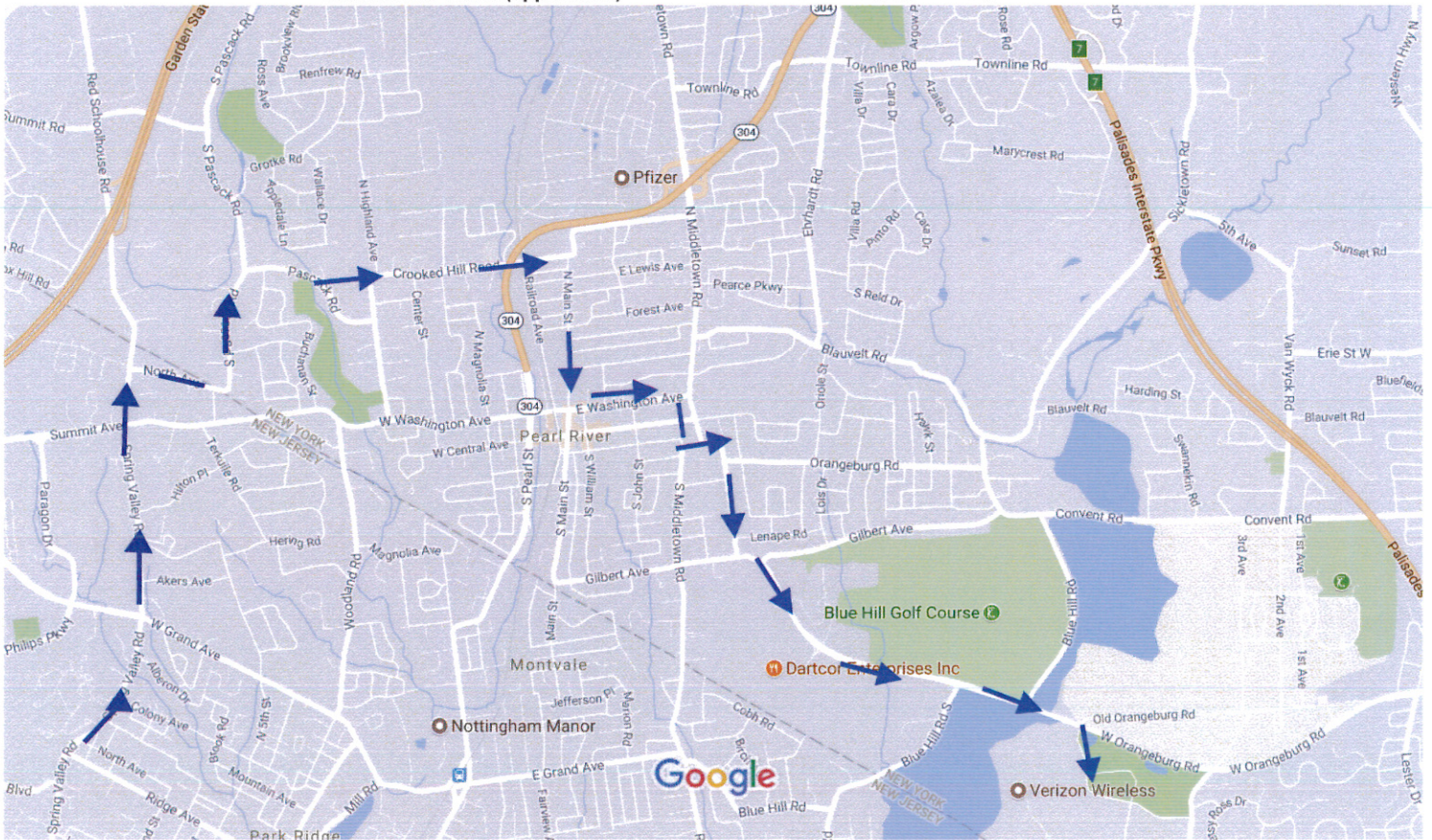

Map data ©2017 Google United States 2000 ft

RECEIVED

AUG 13 2018

TOWN OF ORANGETOWN
HIGHWAY DEPARTMENT

62.5/45 mile riders (approx. 275)

25 mile riders (approx. 200)



25 Mile Start Area
Dynamic Productions
25 Mile Riders join
the 45 and 62.5 Riders
here

RECEIVED

AUG 13 2018

TOWN OF ORANGETOWN
HIGHWAY DEPARTMENT

AUG 13 2018 Velocity 2018

TOWN OF ORANGETOWN
HIGHWAY DEPARTMENT
Route Cues

Travel	Mile Marker	Distance btw Pits	Direction	Route/Street	Special Instructions/Notes	Special Signage Placement
0.1	31.2		R	North Ave		
0.3	31.5			Enter NY State/Rockland County	Enter Pearl River	
0.0	31.5		L	S Pascack Rd		
0.2	31.7				Enter Chestnut Ridge	CAUTION: Blind Curves Ahead
0.3	32.0		BR	to stay on Pascack		
0.3	32.3		L	Crooked Hill Rd		Steep Incline: You Got This!
0.5	32.8				Enter Pearl River	CAUTION: Steep Hill Use Brakes
0.3	33.1		X	Railroad Tracks		
0.1	33.2		R	Main St		
0.6	33.8		L	E Washington Ave		
0.4	34.2		R	N Henry St		
0.1	34.3		X	Central	Stop Sign	CAUTION: Cross Traffic Does NOT Stop
0.0	34.3		L	S Middletown Rd		
0.1	34.4		X	S Middletown Rd on left, continue on Old Middletown Rd		
0.5	34.9		L	Gilbert Ave	Stoplight	
0.1	35.0		X	Gilbert Ave on the left, continue on Veterans Memorial Highway	Blinking Yellow	
0.2	35.2		X	Blue Hills Plaza Rd	Stoplight	
0.2	35.4		X	Blue Hill Plaza Rd	Stoplight	
0.5	35.9		X	Blue Hill Rd	Stoplight	
0.3	36.2		X	Blue Hill Rd	Stoplight	
0.2	36.4		R	Hunt Rd		
0.4	36.8		X	Olympic		
0.1	36.9	15.0	R	Enter Merge Zone 2 - Chromalloy, 25 Mile Start Line		
0.1	37.0		L	Road btw parking lots		
0.1	37.1		R	Blaisdell Rd - to Exit Merge Zone 2 - Chromalloy, 25 Mile Start Line		

**Velocity 2018
Route Cues**

Travel	Mile Marker	Distance btw Pits	Direction	Route/Street	Special Instructions/Notes	Special Signage Placement
0.3	37.4		X	Corporate Dr	Stoplight	
0.1	37.5			End 17 Enter Old Tappan, Blaisdell becomes Dewolf	Enter Old Tappan	

RECEIVED

AUG 13 2018

**TOWN OF ORANGETOWN
HIGHWAY DEPARTMENT**

Contract #	Municipality	Ext. season	Region #
D009818	Town of Orangetown / Rockland County	2018/19	8

AGREEMENT TO EXTEND INDEXED LUMP SUM MUNICIPAL SNOW AND ICE AGREEMENT

This Agreement made this _____ day of _____, _____ by and between THE PEOPLE OF THE STATE OF NEW YORK (hereinafter referred to as "STATE"), acting by and through the Commissioner of Transportation of the State of New York (hereinafter referred to as "COMMISSIONER"), and the _____ of the Town of Orangetown of (hereinafter referred to as "MUNICIPALITY") as follows:

WHEREAS, the COMMISSIONER and the MUNICIPALITY have entered into an Agreement No. D009818 entitled "Indexed Lump Sum Snow and Ice Agreement between the New York State Department of Transportation and the Municipality of Town of Orangetown dated January 16, 1996; and

WHEREAS, the term of the said Agreement is for a period of three years commencing July 1, 1995 and the said Agreement provides that the parties may at the end of each year of the term of the Agreement extend such term for an additional year; and

WHEREAS, the present term of the Agreement, as extended, expires June 30, **2018**; and

WHEREAS, Section 7 of the said Agreement provides that the COMMISSIONER shall furnish the MUNICIPALITY with a suitable map for each term of the Agreement, or for any extended term thereof, modified to show the changes, if any, to the State Highways affected by this Agreement.

WHEREAS, Section 9 of the said Agreement provides for an annual update of the estimated expenditure to be determined by the COMMISSIONER subject to the provisions of Section 9 at the time for extension of the Agreement;

WHEREAS, Section 9 of the said Agreement also provides for an adjustment to the actual payment amount based on the intensity and severity of the winter season;

NOW, THEREFORE, in consideration of the mutual covenants and benefits between the parties,

WITNESSETH:

1. The aforementioned "Indexed Lump Sum Snow and Ice Agreement Between New York State Department of Transportation and the MUNICIPALITY" is hereby extended for a period of one year; now to expire on June 30, **2019**, unless further extended.
2. The State Highways or parts thereof affected by this Agreement are as delineated on the attached map, agreed upon by the COMMISSIONER and the MUNICIPALITY, which shall be effective for the remainder of the term of the Agreement commencing July 1, **2018**, unless changed by future agreement between the COMMISSIONER and the MUNICIPALITY.
3. All the terms and conditions of the original contract remain in effect except as follows. The indexed lump sum estimated expenditure specified in Section 9 of the aforementioned Agreement shall be **\$229,019.82** for 62,50 lane miles for the **2016/17** season and for the remainder of the term of the Agreement commencing July 1, **2016**, unless changed by future update.

IN WITNESS WHEREOF, This Agreement has been executed by the State, acting by and through the duly authorized representative of the COMMISSIONER, and the MUNICIPALITY, which has caused this Agreement to be executed by its duly authorized officer on the date and year first above written.

Over ↘

"In addition to the acceptance of this contract, I also certify that original copies of this signature page will be attached to all other exact copies of this contract."

THE PEOPLE OF THE STATE OF NEW YORK

MUNICIPALITY

BY _____
for Commissioner of Transportation

BY _____

ATTORNEY GENERAL'S SIGNATURE

NYS COMPTROLLER'S SIGNATURE

Dated _____

Dated _____

STATE OF NEW YORK)

) SS:

COUNTY OF Rockland County)

On the _____ day of _____ in the year ____ before me personally came _____ to me known who, being by me duly sworn, did depose and say that he resides in _____, New York; that he is the _____ of _____ the municipality described in and which executed the above instrument; that he executed said instrument by order of the Governing Body of said municipality pursuant to a resolution which was duly adopted on _____; a certified copy of such resolution attached hereto and made a part hereof.

Notary Public

AGREEMENT ADJUSTMENT WORKSHEET
2018/19 Extension Year

Municipality	Town of Orangetown	Contract	D009818
County	Rockland	Region	8

2017/18 Extension's Estimated Expenditure					\$224,709.25	
%	Labor	39.98%	Materials	30.42%	Equipment	29.59%
Value	\$ 89,841.57		\$ 68,366.66		\$ 66,501.02	

LABOR *

Labor Portion of 2017/18 Extension's Estimated Expenditure \$ 89,841.57
 % Labor Increase/Decrease for 2016/17 Season x 2.0% 1796.83
 Additional/Less Labor Costs for 2018/19

Labor Portion of 2018/19 Extension's Estimated Expenditure	\$91,638.40
---	--------------------

* Attach Municipality's certification of applicable labor cost increase

MATERIALS

Materials Portion of 2017/18 Extension's Estimated Expenditure \$ 68,366.66

	% Materials	2017/18 Total Material \$	I. Proportionate \$ Amount	2016/17 Price Per Unit	2015/16 Price Per Unit	Difference (Show +/-)	II. ± ▲ %	I. x II. Inc/Dec
Salt	100%	\$ 68,366.66	\$ 68,366.66	\$71.99	\$71.99	\$0.00	0.00%	\$0.00
Sand								
Other								
Materials Total								\$68,366.66

Materials Portion of 2018/19 Extension's Estimated Expenditure	\$68,366.66
---	--------------------

EQUIPMENT

Equipment Portion of 2017/18 Extension's Estimated Expenditure \$ 66,501.02
 % Equipment Increase/Decrease for 2016/17 Season x 3.78%
 Additional/Less Equipment Costs for 2018/19 \$2,513.74

Equipment Portion of 2018/19 Extension's Estimated Expenditure	\$69,014.76
---	--------------------

2018/19 EXTENSION AMOUNT (Labor + Materials + Equipment)	\$229,019.82
---	---------------------

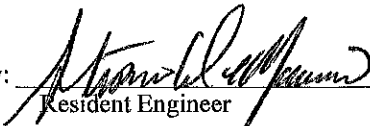
Recommended by:  Approved by: _____
 Resident Engineer S&I Program Manager

MAP SHOWING

TOWN OF ORANGETOWN

RESPONSIBILITY FOR SNOW & ICE CONTROL ON STATE HIGHWAYS FOR THE SEASONS

OF 2016/17 - 2018/19

CENTER LANE MILES	CONTRACT LANE MILES
20.18	62.50



SIGNED

REGIONAL DIRECTOR OF OPERATIONS

DATE

SIGNED

FOR MUNICIPALITY

DATE

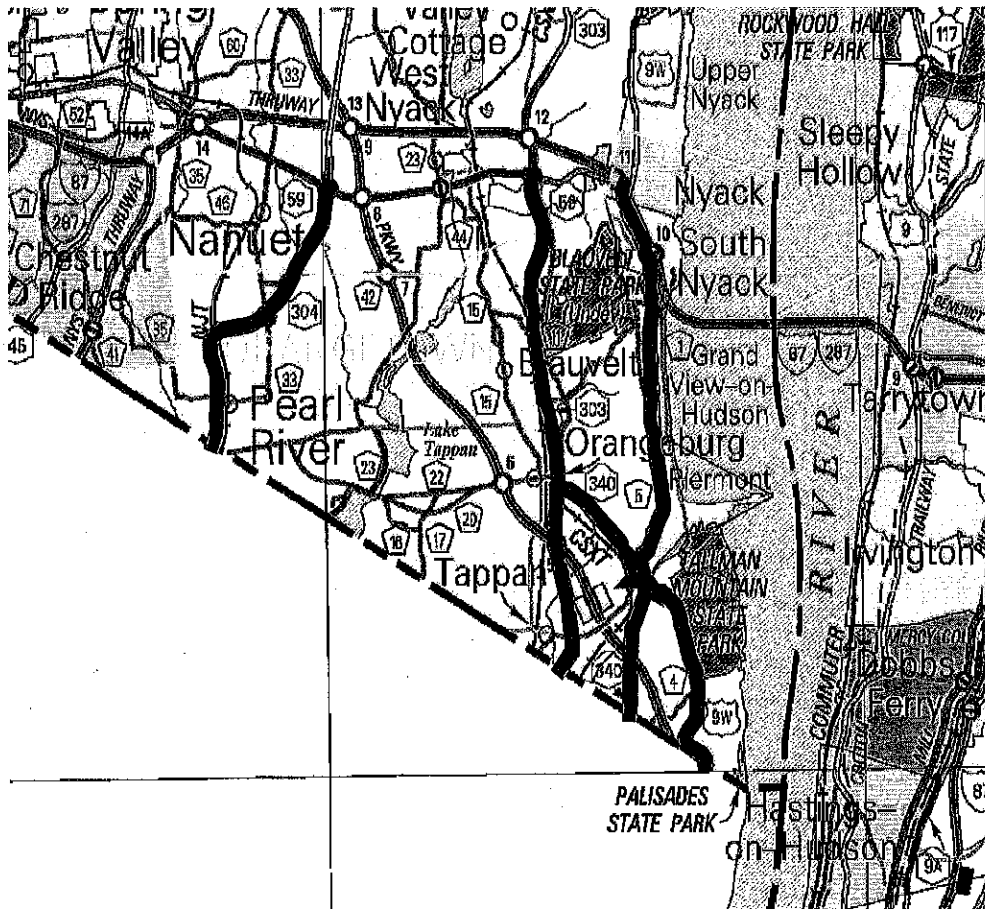

JAMES J. DEAN
Superintendent of Highways
Roadmaster II

Orangetown Representative:
R.C. Soil and Water Conservation Dist.-Chairman
Member:
American Public Works Association NY Metro Chapter
NYS Association of Town Superintendents of Highways
Hwy. Superintendents' Association of Rockland County



HIGHWAY DEPARTMENT
TOWN OF ORANGETOWN
119 Route 303 • Orangeburg, NY 10962
(845) 359-6500 • Fax (845) 359-6062
E-Mail -- highwaydept@orangetown.com

MEMORANDUM

TO: Chris Day, Supervisor

CC: Town Board
Jeffrey Bencik, Finance Director
Amanda Hyland, Confidential Assistant

FROM: James J. Dean, Superintendent of Highways

DATE: September 4, 2018

RE: **Route 340 Sidewalk Project**
Authorize Construction Inspection Services, Supplemental Agreement 5
Lochner Engineering

Please accept this memorandum as a status report for the Route 340 Sidewalk Project. The Project field work was substantially complete on August 11, 2017 and punch list items were completed on December 12, 2017.

For your information, this Project was to be complete by May 1, 2017. As this Project was not completed until December 12, 2017, the Town has incurred \$103,271.52 in additional construction inspection fees from Lochner Engineering.

Please be advised the Town deducted a \$50,000.00 in penalties from payment requisition number 7 paid to Jorrey Excavating, the Project Construction Contractor. (Please see Memo of May 9, 2017). Additionally, please note Jorrey Excavating will be accountable for \$53,271.52 and the Town has deducted this \$53,271.52 from payment requisition number 8.

With knowledge of the above, please place the following item on the Town Board Workshop Agenda of Tuesday, September 4, 2018

“RESOLVED, the Town Board hereby authorizes James J. Dean, Superintendent of Highways, to sign an Agreement Extension with Lochner Engineering for Construction Inspection Services on the Route 340 Sidewalk Project in the amount of \$48,000.00.



RESOLUTION NO. 284

**DETAIL DAVID MADDALENA
DETECTIVE/YOUTH OFFICER**

Under new business, Councilman Bottari offered the following resolution, which was seconded by Councilman Troy and was unanimously adopted:

RESOLVED, that upon the recommendation of the Chief of Police, and in accordance with the terms of Section #13 of the Rockland County Police Act of 1936, as amended, detail David Maddalena to the duties of Detective/Youth Officer, Town of Orangetown, effective May 30, 2017, at a salary consistent with the terms of the labor agreement, between the Town of Orangetown and the Orangetown PBA bargaining unit.

Ayes: Councilpersons Bottari, Troy, Diviny, Valentine
Supervisor Stewart

Noes: None

RESOLUTION NO. 285

**INTENT LEAD AGENCY
CIRCULATION LETTER / ROUTE 303
& GREENBUSH BIKE BYPASS**

Under new business, Supervisor Stewart offered the following resolution, which was seconded by Councilman Valentine and was unanimously adopted:

WHEREAS, the Palisades Interstate Park Commission and the Town of Orangetown propose to enter into a cooperative license agreement, allowing the Town to construct a paved bicycle/pedestrian path, on the east side of Rte. 303, that, when complete, will connect the two ends of Greenbush Road in Blauvelt bypassing the dangerous condition that presently exists at the intersection of Route 303 at Greenbush Road; and

WHEREAS, the License Agreement and the work proposed thereunder constitute an Unlisted Action under the NYS Environmental Quality Review Act ("SEQRA"); and

WHEREAS, in connection with such action, it is the intent of the Town Board to act as lead agency in a coordinated review process,

NOW, THEREFORE, BE IT RESOLVED, that the Town Board hereby declares its intent to be lead agency for environmental review of the proposed action, and directs the circulation thereof to all interested and involved agencies, including but not limited to the following:

Palisades Interstate Park Commission; N.Y.S. Department of Transportation;
N.Y.S. Department of Environmental Conservation; Rockland County Highway
Department; Dormitory Authority of the State of NY (DASNY)

Ayes: Supervisor Stewart
Councilpersons Valentine, Troy, Diviny, Bottari

Noes: None

RESOLUTION NO. 286

**AGREEMENT EXTENSION/LOCHNER
ENGINEERING / CONSTRUCTION
INSPECTION SERVICES / ROUTE 340
SIDEWALK PROJECT**

Under new business, Councilman Diviny offered the following resolution, which was seconded by Supervisor Stewart and was unanimously adopted:

RESOLVED, the Town Board hereby authorizes James J. Dean, Superintendent of Highways, to sign an Agreement Extension, with Lochner Engineering for Construction Inspection Services, on the Route 340 Sidewalk Project, in the amount of \$98,000.00.

Ayes: Councilperson Diviny, Supervisor Stewart
Councilpersons Troy, Valentine, Bottari

Noes: None

LOCHNER

Lochner Engineering, P.C.
181 Genesee St.
Suite 300
Utica, NY 13501

T 315.793.9500
hwlochner.com

Mr. James Dean
Town of Orangetown
119 Route 303
Orangeburg, NY 10962

August 27, 2018

**Re: PIN 8059.03.20 Route 340 Sidewalks, Phase II - Town of Orangetown, Rockland County
Construction Inspection Services SA-5
Lochner No. 2947**

Dear Mr. Dean:

I submitted a supplemental for your consideration and approval in April 2017 based on the latest schedule from Jorrey Construction, which indicated they anticipated completing the construction by June 2, 2017. As you know, construction activities and inspection continued on a full time basis through August 11th 2017. Since August 11th, there has been minor activity including the testing of sidewalks that were placed the previous November without adequate cold weather protection, and then final inspection associated with punch list work the Contractor performed during December 2017. Miscellaneous closeout activities have been progressed. To date we have accumulated charges that exceed the latest construction phase budget by \$35,305.26. If the design underrun is taken into consideration, our total overrun to date is currently \$15,377. This does not include a considerable amount of time that has been worked and not charged in an attempt to wrap up this project and complete the closeout without driving the costs higher. Allowing for another 80 hours of billable time for closeout activities, I estimate a total of \$48,000 will be needed to cover the construction phase overrun. Once again, this total may be able to be reduced by almost \$20,000 if the design underrun funds can be utilized.

Lochner has continued to perform inspection services accruing charges above the contract maximum amount payable based on the understanding the Town would pay for these services and back charge the Contractor who did not uphold contractual obligations regarding the schedule. As a reminder, \$50,000 was withheld from Contractor Payment Application 7 for estimated Engineering Charges. As the actual Engineering Charges total \$103,271.52 since May 2, 2017, the calculated last day of contract work without Engineering Charges or Liquidated Damages, an additional \$53,271.52 was withheld from Contractor Payment Application 8. I am forwarding this supplemental agreement to request the additional funds that are required to cover our costs accumulated to date and through the closeout period. Also recognize I have extended the contract date to December 31, 2018 as I expect the closeout will extend through this timeframe.

If the proposed contract modifications are acceptable, please sign Attachment A in the designated location and return a signed original for our records. Please call if you have any questions or would like to discuss the proposed contract modifications.

Sincerely,



Allen J. Cowen, PE
Project Manager

/tmc

cc: Noel Harris, NYSDOT; Stephen Munno, Town of Orangetown

Attachment A

Supplemental Agreement No.

5

Effective Date

1/1/17

SUPPLEMENTAL AGREEMENT NO. 5

In accordance with Article 7 of the Consulting Services Agreement dated June 12, 2009 ("Agreement") between Town of Orangetown ("CLIENT") and Lochner Engineering, P.C. ("CONSULTANT"), this Supplemental Agreement modifies the Agreement as follows:

1. Change in Services:

Lochner Engineering will provide construction inspection services as described in the cover letter dated April 8, 2017.

2. Change in time of Performance (attach schedule if appropriate):

The Agreement will be extended through December 31, 2018.

3. Change in CONSULTANT's Compensation:

Original Contract	\$150,000
Supplemental No. 1	\$ 15,500
Supplemental No. 2	\$158,000
Supplemental No. 3	\$116,000
Supplemental No. 4	\$ 98,000
Supplemental No. 5	\$48,000
Revised MAP -- Total Contract	\$585,500

All other terms and conditions remain unchanged.

CLIENT

CONSULTANT

Signature

Signature

Name (Printed or Typed)

Allen J. Cowen
Name (Printed or Typed)

Date

Date

LOCHNER

August 17, 2018

Mary Jorrey, President
Jorrey Excavating, Inc.
160 Bart Bull Road
Middletown, NY 10941

Lochner Engineering, P.C.
181 Genesee Street
Suite 300
Utica, NY 13501

T 315.793.9500
F 315.793.9530

hwlochner.com

**Re: PIN 8059.03 Route 340 Sidewalks, Phase II
Town of Orangetown, Rockland County
Lochner No. 2947**

Dear Ms. Jorrey:

I'm forwarding this letter as documentation for the Engineering Charges that are being levied against Jorrey Excavating, Inc. as a result of the missed completion date for the referenced project.

The original Notice to Proceed was made on May 17, 2016. Contract requirements were to complete the work within 180 consecutive calendar days from the NTP. Since the Notice to Proceed was made on May 17, 2016, the completion date was November 13, 2016. As previously documented in a letter sent to you dated April 8, 2017, the Contractor was granted 36 additional days due to additional work that was added to the project. Included within the 36 additional days was an allotment for 4 additional days for the need to utilize the offsite detour, and 8 days to construct an additional bus shelter at Sta. 137+25 left and remove the barrier curb in front of the shelter at Sta. 137+25 right. Because the offsite detour was never used during 2017 and the bus shelter and curb work was never progressed at Sta. 137+25, the allotted 36 day extension will be shortened by 12 days. Acknowledging there was extra work required when you returned in 2017 to complete the work, we are adding 2 days for the construction of the retaining wall, 2 days for pipe extensions at DS-1A, DS-4A and DS-15A, and a half day for steps at house no. 28. These time allotments are based on inspector reports. The final time extension without Engineering Charges or liquidated damages has been calculated to be 36 days - 4 days(offsite detour) - 8 days(bus shelters) + 5 days(additional work) yielding a 29 day extension.

Allowing 29 additional weekdays (exclusive of holidays) to the contract yields a completion date of December 27, 2016. The contract between the Town and your company would allow the Town to assess Engineering Charges or liquidated damages beginning December 28th. However, based on our records, the last day the Contractor actively worked on the project in 2016 was December 16th. Therefore, as an accommodation to Jorrey Excavating and without waiving its rights, the Town agrees that six weekdays will be allowed in 2017 without any Engineering Charges or liquidated damages. With work resuming on April 24, 2017, Engineering Charges have been applied beginning on May 2, 2017.

Jorrey Excavating substantially completed the field work on August 11, 2017. The punch list work was completed on December 12, 2017.

Engineering costs since May 2, 2017 include the following:

Lochner Engineering: Inspection and construction administration labor costs =	\$84,467.01
Lochner Engineering: Expense related costs =	\$ 2,625.51
M.J. Engineering and Land Surveying: Inspection costs =	\$ 6,960.00
Atlantic Testing Laboratories: Materials testing =	\$ 9,219.00

Marry Jorrey
Lochner No. 2947
August 17, 2018
Page 2

Total Engineering Charges Assessed = \$103,271.52

I have entered the total Engineering Charges in Payment Application no. 8 via Pay Item 696.01. I've made a \$50,000 credit in this Payment Application to offset the \$50,000 deduction from Payment Application no. 7 for the Engineering Charges. In Payment Application no. 7, the \$50,000 Engineering Charges were made via a \$42,000 deduct under liquidated damages and an \$8000 payment adjustment; these have both been offset in this current payment application and assigned to the correct payment item.

Respectfully submitted,

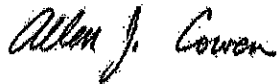

Allen J. Cowen, P.E.
Construction Project Manager

Cc. James Dean, Stephen Munno, Town of Orangetown
Noel Harris, P.E. NYSDOT

JAMES J. DEAN
Superintendent of Highways
Roadmaster II

Orangetown Representative:
R.C. Soil and Water Conservation Dist.-Chairman
Member:
American Public Works Association NY Metro Chapter
NYS Association of Town Superintendents of Highways
Hwy. Superintendents' Association of Rockland County



HIGHWAY DEPARTMENT
TOWN OF ORANGETOWN
119 Route 303 • Orangeburg, NY 10962
(845) 359-6500 • Fax (845) 359-6062
E-Mail – highwaydept@orangetown.com

MEMORANDUM

TO: Andy Stewart, Supervisor

CC: Town Board
Jeffrey Bencik, Finance Director
Kimberly Allen, Executive Assistant

FROM: James J. Dean, Superintendent of Highways

DATE: May 9, 2017

RE: **Route 340 Sidewalk Project**
Authorize Construction Inspection Services Extension
Lochner Engineering

Based upon the latest construction schedule submitted by Jorrey Construction, the Route 340 Sidewalk Project will extend another 13 weeks. This additional construction time will require a supplementary contract extension for construction inspection with Lochner Engineering. Lochner Engineering has submitted a proposal for this Construction Inspection in the amount of \$98,000.00.

For your information, with the council of the Town Attorney's office I have drafted and mailed the attached "Application for Extension of Completion Date Letter" advising Jorrey Construction that they are responsible for all additional costs for engineering services that extend past the contractual 180 days for construction completion and 36 additional days of delays that were agreed upon as beyond the control of the contractor.

As per my attached letter, Jorrey Construction will be accountable for \$50,000.00 of the proposed \$98,000.00 for engineering services which extend beyond the aforementioned 186 days for construction completion.

With knowledge of the above, please place the following item on the Regular Town Board Agenda of Tuesday, May 16, 2017

"RESOLVED, the Town Board hereby authorizes James J. Dean, Superintendent of Highways, to sign an Agreement Extension with Lochner Engineering for Construction Inspection Services on the Route 340 Sidewalk Project in the amount of \$98,000.00.

HAMLETS: PEARL RIVER • BLAUVELT • ORANGETOWN • TAPPAN • SPARKILL • PALISADES • UPPER GRANDVIEW



CLEAN STREETS = CLEAN STREAMS



Preliminary & Final Culvert Replacement Design & Construction Inspection Services for Re-Design of
NYS Rte. 303 Culvert at 400 Rte. 303, Orangeburg, NY, Section, Block and Lot 74.07-1-28, to Mitigate
Sediment Transport & Water Quality Impairment to the Sparkill Creek

MC PROPOSAL NO. 18004814P

FEE SUMMARY

TOTAL

TASK 1: PROJECT FAMILIARIZATION	\$ 1,350.00
TASK 2: MEETINGS	\$ 6,820.00
TASK 3: COST AND PROGRESS REPORTING	\$ 5,660.00
TASK 4: SPECIFICATIONS	\$ 10,180.00
TASK 5: DESIGN SURVEY	\$ 6,210.00
TASK 6: DESIGN MAPPING	\$ 5,610.00
TASK 7: DETERMINATION OF EXISTING CONDITIONS	\$ 6,860.00
TASK 8: SOIL INVESTIGATING	\$ 6,330.00
TASK 9: HYDRAULIC CAPACITY ANALYSIS	\$ 6,240.00
TASK 10: DEVELOPMENT OF ALTERNATIVES	\$ 11,680.00
TASK 11: PUBLIC INFORMATION MEETING(S)	\$ 5,800.00
TASK 12: PRELIMINARY CULVERT PLANS	\$ 18,400.00
TASK 13: REGULATORY PERMITTING	\$ 5,940.00
TASK 14: ADVANCE DETAIL PLANS (ADP)	\$ 24,920.00
TASK 15: CONTRACT DOCUMENTS	\$ 10,790.00
TASK 16: PRE CONSTRUCTION PHASE	\$ 3,350.00
TASK 17: CONSTRUCTION PHASE	\$ 87,530.00
TASK 18: POST CONSTRUCTION PHASE	\$ 4,390.00
SUB TOTAL FOR TASKS 1 THROUGH 18:	\$ 228,060.00

ALLOWANCES

PERMIT FEES	\$ 500.00
SUBCONSULTANT (OSPA)	\$ 9,700.00
SPECIALIZED TESTING ALLOWANCE (SOIL BORINGS)	\$ 7,600.00
FINAL PRINTING	\$ 1,500.00
CERTIFIED MAIL / DELIVERIES	\$ 200.00
TOTAL FOR ALLOWANCES	\$ 19,500.00

SUBCONSULTANT

Total Fee: **\$ 247,560.00**



MAN-HOUR AND DIRECT SALARY COST BREAKDOWN SUMMARY

SHEET 2 OF 2

Preliminary & Final Culvert Replacement Design & Construction Inspection Services
 For the Re-Design of NYS Route 303 Culvert at 400 Route 303, Orangeburg NY, Section, Block and Lot 74.07-1-28,
 To Mitigate Sediment Transport & Water Quality Impairment to the Sparkill Creek

8/8/2018

TASK	TITLE	PRINCIPAL	PROJ. MANAGER	PROJ. ENG.	SR. ENG.	ENG.	CADD DESIGN	CHIEF SURVEYOR	SURVEY TECH.	2-MAN SURVEY CREW	Resident Inspector	PROJECT ENVR.	SR. ENVR. SPEC.	TECH. TYPIST	TOTALS
PROJECT FAMILIARIZATION	(TASK 1)	2	2	0	0	4	0	0	0	0	0	0	0	1	9
MEETINGS	(TASK 2)	2	16	16	0	0	0	0	0	0	0	0	0	8	42
COST AND PROGRESS REPORTING	(TASK 3)	2	16	0	0	12	0	0	0	0	0	0	0	8	38
SPECIFICATIONS	(TASK 4)	2	4	0	40	40	0	0	0	0	0	0	0	0	86
DESIGN SURVEY	(TASK 5)	1	4	0	0	0	0	0	0	24	0	0	0	4	33
DESIGN MAPPING	(TASK 6)	1	4	0	0	0	40	0	0	0	0	0	0	4	49
DETERMINATION OF EXISTING CONDITIONS	(TASK 7)	2	4	16	24	0	0	0	0	0	0	0	0	4	50
SOIL INVESTIGATING	(TASK 8)	1	16	0	0	24	0	0	0	0	0	0	0	4	45
HYDRAULIC CAPACITY ANALYSIS	(TASK 9)	2	4	12	24	0	0	0	0	0	0	0	0	4	46
DEVELOPMENT OF ALTERNATIVES	(TASK 10)	4	8	16	0	24	40	0	0	0	0	0	0	0	92
PUBLIC INFORMATION MEETING(S)	(TASK 11)	4	8	8	0	16	0	0	0	0	0	0	0	4	40
PRELIMINARY CULVERT PLANS	(TASK 12)	4	16	24	0	60	40	0	0	0	0	0	0	0	144
REGULATORY PERMITTING	(TASK 13)	2	4	16	16	0	0	0	0	0	0	0	0	4	42
ADVANCE DETAIL PLANS (ADP)	(TASK 14)	4	16	20	40	60	60	0	0	0	0	0	0	4	204
CONTRACT DOCUMENTS	(TASK 15)	4	8	8	30	30	0	0	0	0	0	0	0	4	84
PRE CONSTRUCTION PHASE	(TASK 16)	1	4	8	0	0	0	0	0	0	12	0	0	0	25
CONSTRUCTION PHASE	(TASK 17)	4	16	80	0	0	0	0	0	0	750	0	0	0	850
POST CONSTRUCTION PHASE	(TASK 18)	1	2	0	0	0	0	0	0	0	40	0	0	0	43
TOTAL HOURS		43	152	224	174	270	180	0	0	24	802	0	0	53	1922
AVERAGE HOURLY BILLING RATE		\$210.00	\$190.00	\$155.00	\$115.00	\$110.00	\$105.00	\$120.00	\$90.00	\$200.00	\$95.00	\$175.00	\$140.00	\$110.00	
TOTALS		\$9,090.00	\$28,880.00	\$34,720.00	\$20,010.00	\$29,700.00	\$18,960.00	\$0.00	\$0.00	\$4,800.00	\$75,190.00	\$0.00	\$0.00	\$5,530.00	\$228,060.00

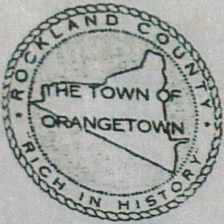

TOWN OF ORANGETOWN PARKS & RECREATION
81 HUNT ROAD, ORANGEBURG, NY 10962
(845) 359-6503

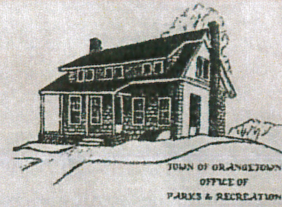

2018 Application for Showmobile Use

Event/Festival Name: Nyack High School Food Truck Festival
Organization Name: Nyack Red & Black Club
Applicant's Name: Mirian Rivera Phone (w): 845-558-0953
Address: P.O. Box 364 City: Nyack Zip: 10960
Cell Phone 845-558-0953 E-Mail: mirianrivera@aol.com
Day Sunday Date 9/30/18 Time of Set-up: 8:00am Time of Take-down: 6:30 pm

Requested Location (park, street, location on premises, etc., be specific, attach map if needed):

131 N. Midland Ave. Nyack, NY 10960 (old Nyack High School)
* on track by steps

Showmobile stage measures **28 feet long x 14 feet 7 inches deep x 25 feet high** when open. One set of stairs is available with hand railings. (Please note that this measurement does not include the trailer hitch or the tow vehicle. See space requirements below.) The Showmobile does not have a sound system and comes with fluorescent lighting only.

Stair Arrangement: (1 set of stairs) Left side of stage Right side of stage Front of stage

The lights require a 110 volt, 20 amp circuit to plug into within 150 feet of the right front side of the Showmobile. The stage does not come with a generator. Additional electrical equipment must be plugged into a separate circuit. Sign or banners may only be hung with permission.

Please describe in detail what the stage will be used for and how you intend to set it up: (Note: The Town seal is not to be covered and no nails, staples or tacks may be used to attach any items to the Showmobile)

Festival is a Food Truck & Music Festival Fundraiser for Nyack School district students. Stage will be used for musician performances.

Showmobile space requirements:

- The showmobile must be parked in a relatively level space.
- The area must be free of obstructions such as overhanging tree limbs, electrical wires, etc.
- **The total area needed for the showmobile is a space 50 feet in length, 15 feet in width and 25 feet in height.**
- The tow vehicle must remain with the showmobile for the duration of the event.
- In the event of winds or wind gusts in excess of 30 MPH, the stage canopy must be closed.

Additional Requirements:

- **Certificate of insurance required at time of reservation** naming the Town of Orangetown as additionally insured.
- **Any changes to the event must be made 24 hours in advance** by contacting Mark Albert at malbert@orangetown.com

I have read, understand and agree to all conditions listed on above:

Applicant's Signature [Signature] Date 6/18/18

Department Approval _____ Date _____

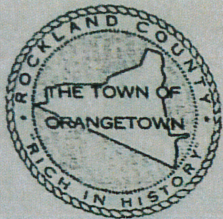

TOWN OF ORANGETOWN PARKS & RECREATION
81 HUNT ROAD, ORANGEBURG, NY 10962
(845) 359-6503

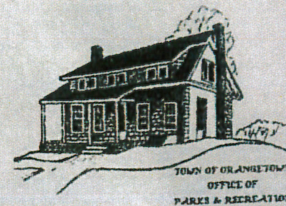

SHOWMOBILE RESERVATION PROCEDURES
Town of Orangetown, Orangeburg NY

The Town of Orangetown through the Parks & Recreation Department supports a variety of non-profit organization community events. Priority scheduling is given to Orangetown Parks & Recreation events and then Town of Orangetown Department requests.

Due to the Orangetown Summer Concert Series the Orangetown Showmobile will not be available beginning July 1st to August 20th this year.

Use of the Showmobile is NOT confirmed until:

1. Your completed application is received by the Orangetown Office of Recreation & Parks.
2. A certificate of insurance listing the Town of Orangetown as additionally insured is provided. Certificate of insurance must accompany the completed application.
3. Your organization has been informed that the application is complete.
4. Your application is approved by resolution by the Orangetown Town Council and the Office of Recreation and Parks has notified you of such.

There are two fees associated with the rental of the Showmobile:

A rental fee of \$400.00 (applicable to all groups)

Staffing overtime (waived by the Town Board for non-profits)

The organization will receive an emailed invoice after their event is complete. Payment is expected no later than 14 days after receipt of such invoice.

Space and Placement

The total area required for the showmobile placement is 50 feet in length, 15 feet in width and 25 feet in height.

The placement of the Showmobile is at the discretion of the Orangetown Parks & Recreation staff. Although all efforts will be made to meet requests, this equipment does not go off road, over curbing or over rough terrain.

A member of the organization renting the unit must be on site at time arrival for proper set up as well as time of departure to assure all event tasks have been completed (i.e. removal of equipment) Any changes/cancellations (unless otherwise agreed upon) to the event must be made 24 hours in advance by contacting Mark Albert at malbert@orangetown.com

By initialing below the applicant agrees to having read the procedures listed above:

(over)

(Renter's initials required)

 MA



CERTIFICATE OF LIABILITY INSURANCE

DATE (MM/DD/YYYY)

08/29/2018

THIS CERTIFICATE IS ISSUED AS A MATTER OF INFORMATION ONLY AND CONFERS NO RIGHTS UPON THE CERTIFICATE HOLDER. THIS CERTIFICATE DOES NOT AFFIRMATIVELY OR NEGATIVELY AMEND, EXTEND OR ALTER THE COVERAGE AFFORDED BY THE POLICIES BELOW. THIS CERTIFICATE OF INSURANCE DOES NOT CONSTITUTE A CONTRACT BETWEEN THE ISSUING INSURER(S), AUTHORIZED REPRESENTATIVE OR PRODUCER, AND THE CERTIFICATE HOLDER.

IMPORTANT: If the certificate holder is an ADDITIONAL INSURED, the policy(ies) must have ADDITIONAL INSURED provisions or be endorsed. If SUBROGATION IS WAIVED, subject to the terms and conditions of the policy, certain policies may require an endorsement. A statement on this certificate does not confer rights to the certificate holder in lieu of such endorsement(s).

PRODUCER Bauer-Crowley, Inc. 643 Main Street PO Box 358 Sparkill NY 10976-0358	CONTACT NAME: James Wymko PHONE (A/C, No, Ext): (845) 359-4114 E-MAIL ADDRESS: jimw@bauercrowley.com	FAX (A/C, No): (845) 359-4684
	INSURER(S) AFFORDING COVERAGE	
INSURED Nyack Red and Black Booster Club P.O. Box 364 Nyack NY 10960	INSURER A: Mount Vernon Fire Insurance Company	NAIC # 26522
	INSURER B:	
	INSURER C:	
	INSURER D:	
	INSURER E:	
	INSURER F:	

COVERAGES

CERTIFICATE NUMBER: CL1711208692

REVISION NUMBER:

THIS IS TO CERTIFY THAT THE POLICIES OF INSURANCE LISTED BELOW HAVE BEEN ISSUED TO THE INSURED NAMED ABOVE FOR THE POLICY PERIOD INDICATED. NOTWITHSTANDING ANY REQUIREMENT, TERM OR CONDITION OF ANY CONTRACT OR OTHER DOCUMENT WITH RESPECT TO WHICH THIS CERTIFICATE MAY BE ISSUED OR MAY PERTAIN, THE INSURANCE AFFORDED BY THE POLICIES DESCRIBED HEREIN IS SUBJECT TO ALL THE TERMS, EXCLUSIONS AND CONDITIONS OF SUCH POLICIES. LIMITS SHOWN MAY HAVE BEEN REDUCED BY PAID CLAIMS.

INSR LTR	TYPE OF INSURANCE	ADDL INSD	SUBR WVD	POLICY NUMBER	POLICY EFF (MM/DD/YYYY)	POLICY EXP (MM/DD/YYYY)	LIMITS
A	<input checked="" type="checkbox"/> COMMERCIAL GENERAL LIABILITY			QNBPO17L0370	11/07/2017	11/07/2018	EACH OCCURRENCE \$ 1,000,000
	<input type="checkbox"/> CLAIMS-MADE <input checked="" type="checkbox"/> OCCUR						DAMAGE TO RENTED PREMISES (Ea occurrence) \$
	GEN'L AGGREGATE LIMIT APPLIES PER:						MED EXP (Any one person) \$ 5,000
	<input checked="" type="checkbox"/> POLICY <input type="checkbox"/> PROJECT <input type="checkbox"/> LOC						PERSONAL & ADV INJURY \$
	OTHER:						GENERAL AGGREGATE \$ 2,000,000
	AUTOMOBILE LIABILITY						PRODUCTS - COMP/OP AGG \$
	<input type="checkbox"/> ANY AUTO						Damage to Premises \$ 100,000
	<input type="checkbox"/> OWNED AUTOS ONLY	<input type="checkbox"/> SCHEDULED AUTOS					COMBINED SINGLE LIMIT (Ea accident) \$
	<input type="checkbox"/> HIRED AUTOS ONLY	<input type="checkbox"/> NON-OWNED AUTOS ONLY					BODILY INJURY (Per person) \$
	<input type="checkbox"/> UMBRELLA LIAB	<input type="checkbox"/> OCCUR					BODILY INJURY (Per accident) \$
	<input type="checkbox"/> EXCESS LIAB	<input type="checkbox"/> CLAIMS-MADE					PROPERTY DAMAGE (Per accident) \$
	DED	RETENTION \$					\$
	WORKERS COMPENSATION AND EMPLOYERS' LIABILITY						PER STATUTE
	ANY PROPRIETOR/PARTNER/EXECUTIVE OFFICER/MEMBER EXCLUDED? (Mandatory in NH)	<input type="checkbox"/> Y <input type="checkbox"/> N	N/A				OTH-ER
	If yes, describe under DESCRIPTION OF OPERATIONS below						E.L. EACH ACCIDENT \$
							E.L. DISEASE - EA EMPLOYEE \$
							E.L. DISEASE - POLICY LIMIT \$

DESCRIPTION OF OPERATIONS / LOCATIONS / VEHICLES (ACORD 101, Additional Remarks Schedule, may be attached if more space is required)

Date of Event: 9/30/2018

CERTIFICATE HOLDER**CANCELLATION**

Town of Orangetown 81 Hunt Ave Orangeburg NY 10962	SHOULD ANY OF THE ABOVE DESCRIBED POLICIES BE CANCELLED BEFORE THE EXPIRATION DATE THEREOF, NOTICE WILL BE DELIVERED IN ACCORDANCE WITH THE POLICY PROVISIONS. AUTHORIZED REPRESENTATIVE 
--	--

© 1988-2015 ACORD CORPORATION. All rights reserved.

**AMENDMENT TO
BLUE HILL GOLF CLUB MANAGEMENT AGREEMENT
BETWEEN
THE TOWN OF ORANGETOWN, As Owner
AND
APPLIEDGOLF, LLC, As Manager**

This Agreement, dated October _____, 2018, is made by and between the Town of Orangetown (hereinafter referred to as the “TOWN”) and APPLIEDGOLF, LLC. (hereinafter “APPLIEDGOLF”). The TOWN and APPLIEDGOLF are parties to an agreement, dated December 18, 2015, entitled the Blue Hill Golf Club Management Agreement (hereinafter referred to as the “Agreement”), for APPLIEDGOLF’s to manage the golf operations at Blue Hill Golf Club, as an independent contractor, from January 1, 2016, through December 31, 2018.

In 2015 the Town issued a Requests for Proposals (“RFP”) for the management and operation of the Blue Hill Golf Course, which RFP provided for an initial term of three years with an option to renew for an additional two years. Throughout the term of the Agreement, APPLIEDGOLF demonstrated that it has the specialized skills, expertise and knowledge to successfully manage the Blue Hill Golf Course and, as a result, the TOWN has opted to extend the Agreement for the additional two year period.

In consideration of the mutual covenants and promises contained in the Agreement, and other good and valuable consideration, the receipt and sufficiency of which are hereby acknowledged, the Agreement is hereby amended to extend the term through and including December 31, 2020.

Except as otherwise provided for in this Amendment, the Agreement shall remain in full force and effect in accordance with the original terms of the Agreement.

The execution of this Amendment on behalf of the TOWN was approved by resolution of the Town Board, duly adopted _____, 2018.

IN WITNESS WHEREOF, the PARTIES have caused this instrument to be signed by their authorized officers and have caused their corporate or business entity seals to be affixed hereto.

Dated: Orangeburg, New York
October , 2018

TOWN OF ORANGETOWN

By: _____
Chris Day, Supervisor

APPLIEDGOLF, LLC.

By: _____
David Wasenda, President

Acknowledgements

STATE OF NEW YORK)
 : SS.:
COUNTY OF ROCKLAND)

On the _____ day of October, 2018, personally came, Chris Day to me known, who being by me duly sworn, did depose and say that he is the Town Supervisor of the Town of Orangetown, the corporation described in and which executed the foregoing instrument; that he knows the seal of said corporation; that the seal affixed to said instrument is such corporate seal; and the same was affixed to said instrument under authority of the Town Board and that he signed his name thereto under the same authority.

Notary Public

STATE OF NEW YORK)
 : SS.:
COUNTY OF ROCKLAND)

On the _____ day of October, 2018, before me personally appeared David Wasenda, personally known to me or proved to me on the basis of satisfactory evidence to be the individual whose name is subscribed to the within instrument and acknowledged to me that he executed the same in his capacity and that by his signature on the instrument, the individual, or the person upon behalf of the individual acted, executed the instrument.

Notary Public

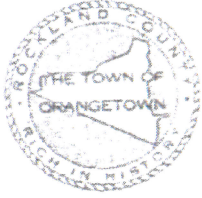

TOWN OF ORANGETOWN PARKS & RECREATION
 81 HUNT ROAD, ORANGEBURG, NY 10962
 (845) 359-6503



2018 Application for Showmobile Use

Event/Festival Name: TRaubenfest At German Masonic Park

Organization Name The Noble Ninth Inc

Applicant's Name: MARK Ramparilli Phone (w): 516 236 3847

Address: 24 CARSTON ST City: Selden, NY Zip: 11784

Cell Phone 516 236 3847 E-Mail: saltcay 01 @GMAIL .com

Day Sunday Date 10/7/2018 Time of Set-up: ^{Between} 8-9am Time of Take-down: 7pm

Requested Location (park, street, location on premises, etc., be specific, attach map if needed):

German Masonic Park 89 Western Hwy, TAPPAN NY 10983

Showmobile stage measures **28 feet long x 14 feet 7 inches deep x 25 feet high** when open. One set of stairs is available with hand railings. (Please note that this measurement does not include the trailer hitch or the tow vehicle. See space requirements below.) The Showmobile does not have a sound system and comes with fluorescent lighting only.

Stair Arrangement: (1 set of stairs) Left side of stage Right side of stage Front of stage

The lights require a 110 volt, 20 amp circuit to plug into within 150 feet of the right front side of the Showmobile. The stage does not come with a generator. Additional electrical equipment must be plugged into a separate circuit. Sign or banners may only be hung with permission.

Please describe in detail what the stage will be used for and how you intend to set it up: (**Note: The Town seal is not to be covered and no nails, staples or tacks may be used to attach any items to the Showmobile**)

Polka Band maximum of 10 musicians on stage

Showmobile space requirements:

- The showmobile must be parked in a relatively level space.
- The area must be free of obstructions such as overhanging tree limbs, electrical wires, etc.
- **The total area needed for the showmobile is a space 50 feet in length, 15 feet in width and 25 feet in height.**
- The tow vehicle must remain with the showmobile for the duration of the event.
- In the event of winds or wind gusts in excess of 30 MPH, the stage canopy must be closed.

Additional Requirements:

- **Certificate of insurance required at time of reservation** naming the Town of Orangetown as additionally insured
- Any changes to the event must be made 24 hours in advance by contacting Mark Albert at malbert@orangetown.com

I have read, understand and agree to all conditions listed on above:

Applicant's Signature [Signature] Date 7/26/18

Department Approval [Signature] Date 9/4/18



CERTIFICATE OF LIABILITY INSURANCE

DATE (MM/DD/YYYY)

07/27/2018

THIS CERTIFICATE IS ISSUED AS A MATTER OF INFORMATION ONLY AND CONFERS NO RIGHTS UPON THE CERTIFICATE HOLDER. THIS CERTIFICATE DOES NOT AFFIRMATIVELY OR NEGATIVELY AMEND, EXTEND OR ALTER THE COVERAGE AFFORDED BY THE POLICIES BELOW. THIS CERTIFICATE OF INSURANCE DOES NOT CONSTITUTE A CONTRACT BETWEEN THE ISSUING INSURER(S), AUTHORIZED REPRESENTATIVE OR PRODUCER, AND THE CERTIFICATE HOLDER.

IMPORTANT: If the certificate holder is an ADDITIONAL INSURED, the policy(ies) must have ADDITIONAL INSURED provisions or be endorsed. If SUBROGATION IS WAIVED, subject to the terms and conditions of the policy, certain policies may require an endorsement. A statement on this certificate does not confer rights to the certificate holder in lieu of such endorsement(s).

PRODUCER Wilkinson & Krause Agency Inc 75B Montauk Hwy Blue Point, NY 11715	CONTACT NAME: Jourdan Lopez PHONE (A/C, No, Ext): 631-567-1111 E-MAIL ADDRESS: Info@5starcoverage.com	FAX (A/C, No): 631-218-3411	
	INSURER(S) AFFORDING COVERAGE		NAIC #
INSURED The Noble Ninth Inc 149-39 11th Avenue Whitestone, NY 11357	INSURER A: U.S. UNDERWRITERS INSURANCE CO.		35416
	INSURER B:		
	INSURER C:		
	INSURER D:		
	INSURER E:		
	INSURER F:		

COVERAGES **CERTIFICATE NUMBER:** 00000000-264564 **REVISION NUMBER:** 2

THIS IS TO CERTIFY THAT THE POLICIES OF INSURANCE LISTED BELOW HAVE BEEN ISSUED TO THE INSURED NAMED ABOVE FOR THE POLICY PERIOD INDICATED. NOTWITHSTANDING ANY REQUIREMENT, TERM OR CONDITION OF ANY CONTRACT OR OTHER DOCUMENT WITH RESPECT TO WHICH THIS CERTIFICATE MAY BE ISSUED OR MAY PERTAIN, THE INSURANCE AFFORDED BY THE POLICIES DESCRIBED HEREIN IS SUBJECT TO ALL THE TERMS, EXCLUSIONS AND CONDITIONS OF SUCH POLICIES. LIMITS SHOWN MAY HAVE BEEN REDUCED BY PAID CLAIMS.

INSR LTR	TYPE OF INSURANCE	ADDL INSD	SUBR WVD	POLICY NUMBER	POLICY EFF (MM/DD/YYYY)	POLICY EXP (MM/DD/YYYY)	LIMITS	
A	<input checked="" type="checkbox"/> COMMERCIAL GENERAL LIABILITY <input type="checkbox"/> CLAIMS-MADE <input type="checkbox"/> OCCUR GEN'L AGGREGATE LIMIT APPLIES PER: <input checked="" type="checkbox"/> POLICY <input type="checkbox"/> PRO-JECT <input type="checkbox"/> LOC OTHER:	Y		NPP3552521	10/05/2017	10/05/2018	EACH OCCURRENCE	\$ 1,000,000
							DAMAGE TO RENTED PREMISES (Ea occurrence)	\$ 100,000
							MED EXP (Any one person)	\$ 5,000
							PERSONAL & ADV INJURY	\$ 1,000,000
							GENERAL AGGREGATE	\$ 2,000,000
							PRODUCTS - COM/OP AGG	\$ 2,000,000
								\$
	AUTOMOBILE LIABILITY <input type="checkbox"/> ANY AUTO <input type="checkbox"/> OWNED AUTOS ONLY <input type="checkbox"/> SCHEDULED AUTOS <input type="checkbox"/> HIRED AUTOS ONLY <input type="checkbox"/> NON-OWNED AUTOS ONLY						COMBINED SINGLE LIMIT (Ea accident)	\$
							BODILY INJURY (Per person)	\$
							BODILY INJURY (Per accident)	\$
							PROPERTY DAMAGE (Per accident)	\$
								\$
A	<input checked="" type="checkbox"/> UMBRELLA LIAB <input type="checkbox"/> OCCUR <input type="checkbox"/> EXCESS LIAB <input checked="" type="checkbox"/> CLAIMS-MADE DED RETENTION \$			XL1581858	10/05/2017	10/05/2018	EACH OCCURRENCE	\$ 2,000,000
							AGGREGATE	\$ 2,000,000
								\$
	WORKERS COMPENSATION AND EMPLOYERS' LIABILITY ANY PROPRIETOR/PARTNER/EXECUTIVE OFFICER/MEMBER EXCLUDED? (Mandatory in NH) If yes, describe under DESCRIPTION OF OPERATIONS below	Y/N	N/A				PER STATUTE	OTH-ER
							E.L. EACH ACCIDENT	\$
							E.L. DISEASE - EA EMPLOYEE	\$
							E.L. DISEASE - POLICY LIMIT	\$

DESCRIPTION OF OPERATIONS / LOCATIONS / VEHICLES (ACORD 101, Additional Remarks Schedule, may be attached if more space is required)
Certificate holder is named as additional insured

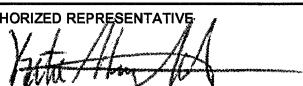
CERTIFICATE HOLDER TOWN OF ORANGETOWN PARKS & RECREATION 81 HUNT RD Orangeburg, NY 10962	CANCELLATION SHOULD ANY OF THE ABOVE DESCRIBED POLICIES BE CANCELLED BEFORE THE EXPIRATION DATE THEREOF, NOTICE WILL BE DELIVERED IN ACCORDANCE WITH THE POLICY PROVISIONS. AUTHORIZED REPRESENTATIVE  (JCL)
--	---

© 1988-2015 ACORD CORPORATION. All rights reserved.

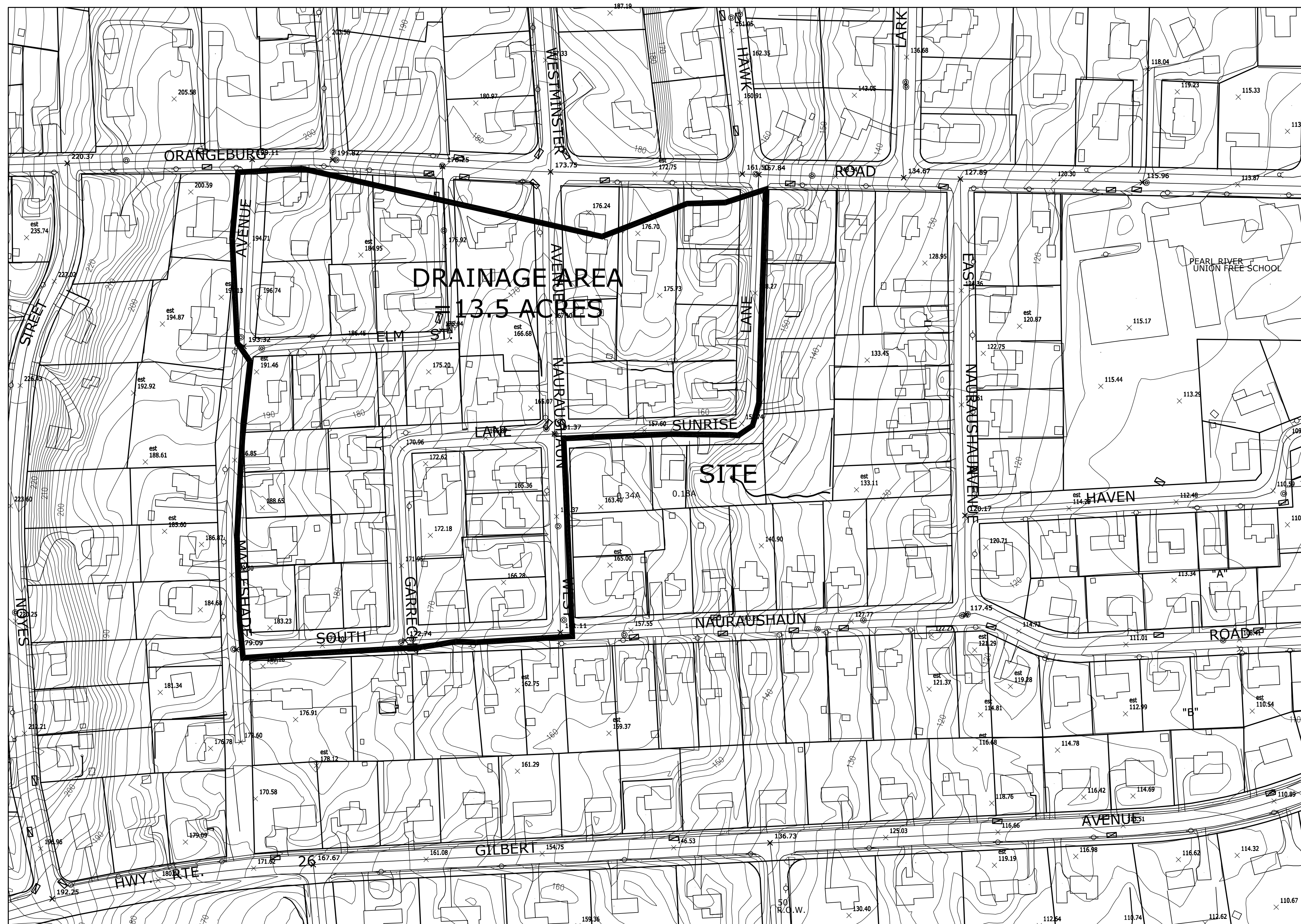

DRAINAGE AREA MAP

TAX MAP SECTION 69.18
 BLOCK 3, LOT 43.2
 PLOT PLAN
 FOR

KREIGER ESTATE

27 SUNRISE LANE
 HAMLET OF PEARL RIVER
 TOWN OF ORANGETOWN
 ROCKLAND COUNTY, NEW YORK

PAUL GDANSKI P.E., PLLC

25 RIVERSIDE DRIVE
 SUFFERN, N.Y. 10901
 TEL: (917) 418-0999

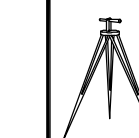

FILE 27SUNRISE

JAN. 06, 2018

AS SHOWN

1 OF 1

UNAUTHORIZED ALTERATION OR ADDITION TO THIS PLAN IS A VIOLATION OF SECTION 7209(2) OF THE NEW YORK STATE EDUCATION LAW. COPIES OF THIS MAP NOT HAVING THE SEAL OF THE SURVEYOR OR ENGINEER SHALL NOT BE VALID.

CERTIFICATIONS ARE NOT TRANSFERABLE TO ADDITIONAL INSTITUTIONS OR SUBSEQUENT OWNERS. USE OF UNSEALED COPIES OF THIS DOCUMENT IN ANY COURT, FINANCIAL, OR ANY TRANSACTION OR FILING WITH ANY PUBLIC AGENCY OR OFFICE IS AN UNAUTHORIZED USE AND A VIOLATION OF FEDERAL, STATE AND LOCAL LAWS.



REFERENCES:

BEING SHOWN AS LOT #2 ON A CERTAIN MAP ENTITLED FINAL KREIGER SUBDIVISION PLAN PREPARED BY ROBERT E. SORACE, PLS FILED IN THE ROCKLAND COUNTY CLERK'S OFFICE ON APRIL 18, 2017 IN BOOK #130 ON PAGE #100 AS MAP #8356.

NOTE:
1. AT LEAST ONE WEEK PRIOR TO COMMENCEMENT OF ANY WORK INCLUDING THE INSTALLATION OF EROSION CONTROL DEVICES OR THE REMOVAL OF TREES AND VEGETATION A PRE-CONSTRUCTION MEETING MUST BE HELD WITH THE TOWN OF ORANGETOWN DEPARTMENT OF ENVIRONMENTAL MANAGEMENT & ENGINEERING, SUPERINTENDENT OF HIGHWAYS AND THE OFFICE OF BUILDING, ZONING AND PLANNING ADMINISTRATION AND IT IS THE RESPONSIBILITY AND OBLIGATION OF THE PROPERTY OWNER TO ARRANGE SUCH A MEETING.
2. STORMWATER MANAGEMENT PHASE II REGULATIONS ADDITIONAL CERTIFICATION BY AN APPROPRIATE LICENSED OR CERTIFIED DESIGN PROFESSIONAL SHALL BE REQUIRED FOR ALL MATTERS BEFORE THE PLANNING BOARD INDICATING THAT THE DRAWINGS AND PROJECT ARE IN COMPLIANCE WITH THE STORMWATER MANAGEMENT PHASE II REGULATIONS.
3. THE TREE PROTECTION AND PRESERVATION GUIDELINES ADOPTED PURSUANT TO SECTION 21-24 OF THE LAND DEVELOPMENT REGULATIONS OF THE TOWN OF ORANGETOWN WILL BE IMPLEMENTED IN ORDER TO PROTECT AND PRESERVE BOTH INDIVIDUAL SPECIMEN TREES AND BUFFER AREA WITH MANY TREES. STEPS THAT WILL BE TAKEN TO RESERVE AND PROTECT EXISTING TREES TO REMAIN ARE AS FOLLOWS:
A. NO CONSTRUCTION EQUIPMENT SHALL BE PARKED UNDER TREE CANOPY.
B. THERE WILL BE NO EXCAVATION OR STOCKPILING OF EARTH UNDERNEATH THE TREES.
C. TREES DESIGNATED TO BE PRESERVED SHALL BE MARKED CONSPICUOUSLY ON ALL SIDES AT A 5 TO 10 FOOT HEIGHT.
D. THE TREE PROTECTION ZONE FOR TREES DESIGNATED TO BE PRESERVED WILL BE ESTABLISHED BY ONE OF THE FOLLOWING METHODS:
- ONE (1) FOOT RADIUS FROM TRUNK PER INCH DBH - DRIP LINE OF THE TREE CANOPY.
THE METHOD CHOSEN SHOULD BE BASED ON PROVIDING THE MAXIMUM PROTECTION ZONE POSSIBLE. A BARRIER OF SNOW FENCE OR QUAL IS TO BE PLACED AND MAINTAINED ONE YARD BEYOND THE ESTABLISHED TREE PROTECTION ZONE. IF IT IS ASCERTAINED THAT THE TREE PROTECTION ZONE OF A SELECTED TREE MUST BE VIOLATED, ONE OF THE FOLLOWING METHODS MUST BE EMPLOYED TO MITIGATE THE IMPACT:
- LIGHT TO HEAVY IMPACTS - MINIMUM OF EIGHT INCHES OF WOOD CHIPS INSTALLED IN THE AREA TO BE PROTECTED. CHIPS SHALL BE REMOVED UPON COMPLETION OF WORK.
- LIGHT IMPACTS ONLY - INSTALLATION OF 5/4" OF PLYWOOD OR BOARDS, OR EQUAL OVER THE AREA TO BE PROTECTED.
THE BUILDER OR ITS AGENT MAY NOT CHANGE GRADE WITHIN THE TREE PROTECTION ZONE OF A PRESERVED TREE UNLESS SUCH GRADE CHANGE HAS RECEIVED FINAL APPROVAL FOR THE PLANNING BOARD. IF THE GRADE LEVEL IS TO BE CHANGED MORE THAN (6) SIX INCHES, TREES DESIGNATED TO BE PRESERVED SHALL BE WELLED AND/OR PRESERVED IN A RAISED BED WITH THE TREE PROTECTION ZONE OF THREE (3) FEET LARGER THAN THE TREE CANOPY.
4. ALL LANDSCAPING SHOWN ON THE SITE PLANS SHALL BE MAINTAINED IN A VIGOROUS GROWING CONDITION THROUGHOUT THE DURATION OF THE USE OF THE SITE. ANY PLANTS NOT SO MAINTAINED SHALL BE REPLACED WITH NEW PLANTS AT THE BEGINNING OF THE NEXT IMMEDIATELY FOLLOWING GROWING SEASON.
5. PRIOR TO THE COMMENCEMENT OF ANY SITE WORK INCLUDING THE REMOVAL OF TREES THE APPLICANT SHALL INSTALL SOIL EROSION AND SEDIMENTATION CONTROL AS REQUIRED BY THE PLANNING BOARD.
PRIOR TO THE AUTHORIZATION TO PROCEED WITH ANY PHASE OF THE SITE WORK, THE TOWN OF ORANGETOWN DEPARTMENT OF ENVIRONMENTAL MANAGEMENT AND ENGINEERING SHALL AT LEAST 48 HOURS IN ADVANCE OF AN INSPECTION.
6. THE CONTRACTOR'S TRAILER, IF ANY IS PROPOSED, SHALL BE LOCATED AS APPROVED BY THE PLANNING BOARD.
7. IF THE APPLICANT, DURING THE COURSE OF CONSTRUCTION ENCOUNTERS SUCH CONDITIONS AS FLOOD AREAS, UNDERGROUND WATER, SOFT OR SILTY AREAS, IMPROPER DRAINAGE, OR ANY OTHER UNUSUAL CIRCUMSTANCES OR CONDITIONS THAT WERE NOT FORESEEN IN THE ORIGINAL PLANNING, SUCH CONDITIONS SHALL BE REPORTED IMMEDIATELY TO DENE. THE APPLICANT SHALL SUBMIT THEIR RECOMMENDATIONS AS TO THE SPECIAL TREATMENT TO BE GIVEN SUCH AREAS TO SECURE ADEQUATE PERMANENT AND SATISFACTORY CONSTRUCTION. DENE SHALL INVESTIGATE THE CONDITIONS, AND SHALL EITHER APPROVE THE APPLICANT'S RECOMMENDATIONS TO CORRECT THE CONDITIONS, OR ORDER A MODIFICATION THEREOF. IN THE EVENT OF THE APPLICANT'S DISAGREEMENT WITH THE DECISION OF DENE, OR IN THE EVENT OF A SIGNIFICANT CHANGE RESULTING TO THE SUBDIVISION PLAN OR SITE PLAN OR ANY CHANGE THAT INVOLVES A WETLAND REGULATED AREA, THE MATTER SHALL BE DECIDED BY THE AGENCY WITH JURISDICTION IN THAT AREA, THE NEW YORK STATE DEPARTMENT OF ENVIRONMENTAL CONSERVATION.
8. PERMANENT VEGETATION COVER OF DISTURBED AREAS SHALL BE ESTABLISHED ON THE SITE WITHIN THIRTY(30) DAYS OF THE COMPLETION OF CONSTRUCTION.
9. PRIOR AT LEAST (14) DAYS TO THE PLACING OF ANY ROAD SUB-BASE, THE APPLICANT SHALL PROVIDE THE TOWN OF ORANGETOWN SUPERINTENDENT OF HIGHWAYS AND DENE WITH A PLAN AND PROFILE OF THE GRADED ROAD TO BE PAVED IN ORDER THAT THESE DEPARTMENTS MAY REVIEW THE DRAWINGS AND APPROVE THE APPROVED CONSTRUCTION PLANS AND THE TOWN STREET SPECIFICATIONS.
10. THE PLANNING BOARD SHALL RETAIN JURISDICTION OVER LIGHTING, LANDSCAPING, SIGNS AND REFUSE CONTROL.
11. ZONE: R-15
12. DISTRICTS:
PEARL RIVER FIRE DISTRICT
PEARL RIVER SCHOOL DISTRICT
SUEZ WATER SEWER TOWN OF ORANGETOWN

UNAUTHORIZED ALTERATION OR ADDITION TO THIS PLAN IS A VIOLATION OF SECTION 209(2) OF THE NEW YORK STATE EDUCATION LAW. COPIES OF THIS MAP NOT HAVING THE SEAL OF THE SURVEYOR OR ENGINEER SHALL NOT BE VALID.
CERTIFICATIONS ARE NOT TRANSFERABLE TO ADDITIONAL INSTITUTIONS OR SUBSEQUENT OWNERS.
USE OF UNSEAL OR UNREGISTERED DOCUMENT OR FILING WITH THE OFFICE OF FEDERAL LAND MANAGEMENT AND RECLAMATION IS PROHIBITED.
PAUL GDANSKI PROFESSIONAL ENGINEER NO. 07890 ©

USE 2
UNDERGROUND UTILITIES ARE SHOWN IN AN APPROXIMATE WAY FROM AVAILABLE INFORMATION. THE CONTRACTOR SHALL CALL THE LOCAL UNDERGROUND UTILITIES PROTECTIVE ORGANIZATION TO HAVE ALL UNDERGROUND UTILITIES MARKED IN THE FIELD PRIOR TO ANY CLEARING OR ANY CONSTRUCTION. THE CONTRACTOR SHALL ALSO VERIFY THE LOCATION, SIZE AND INVERT OF ALL UTILITIES PRIOR TO ANY CONSTRUCTION. ANY UTILITY FOR WHICH NO EVIDENCE CAN BE SEEN ON THE SURFACE OF THE LANDS MAY NOT BE SHOWN ON THIS DRAWING.

BULK REQUIREMENTS ZONE: R-15

USE GROUP	MINIMUM LOT AREA	LOT WIDTH (FEET)	FRONT YARD (FEET)	SIDE YARD (FEET)	TOTAL SIDE YARD (FEET)	REAR YARD (FEET)	STREET FRONTAGE (FEET)	MAXIMUM HEIGHT (FEET)	FLOOR AREA RATIO (FAR)
REQ'D	15,000 SF	100	30	20	50	35	75	1 FT. FT. FROM LOT LINE	0.20
PROD.	16,434 SF	120	30.0	20.0	72.5	35.0	110.0	430	0.19

FAR CALCULAS PER ARCH
1ST FLOOR=1.767 SF
2ND FLOOR=1.406 SF
TOTAL=3173/16434=1.931=19

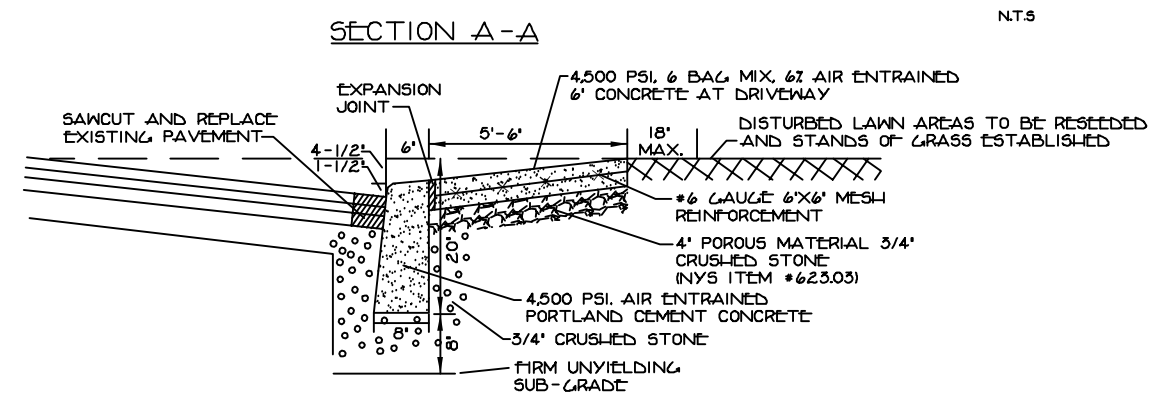
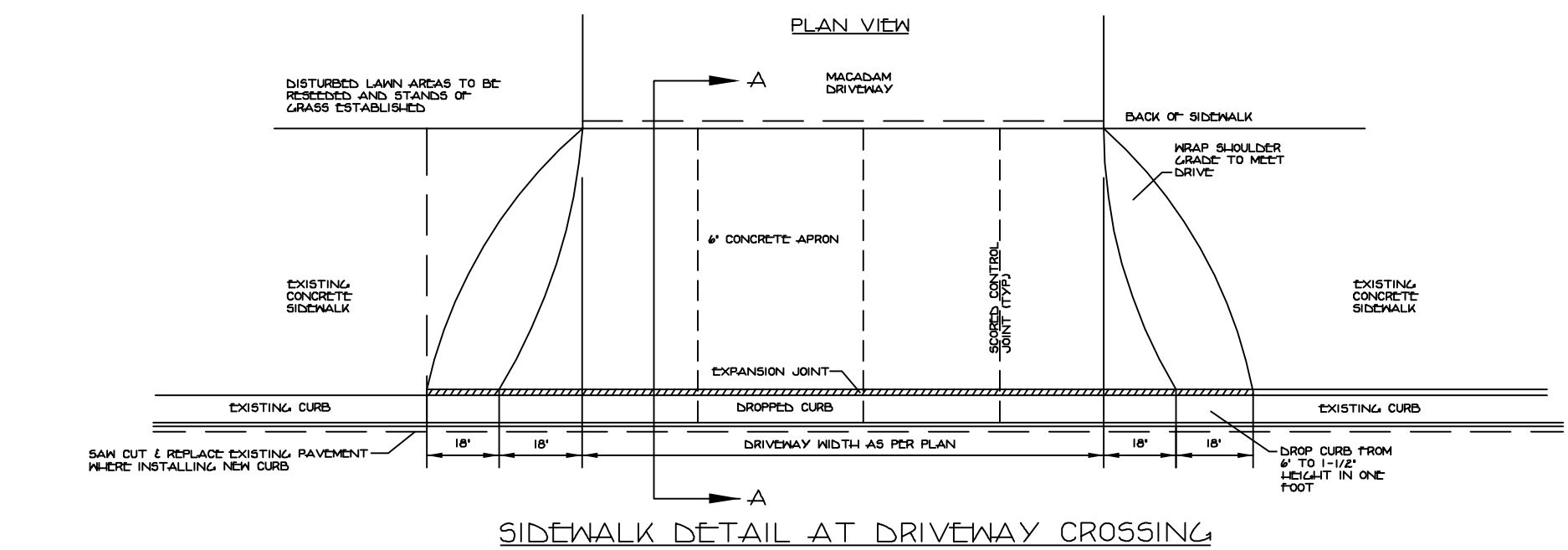

Drywell Design

- DEVELOPMENT SIZE = 0.0668 ACRE
- UNDEVELOPED SC5 CURVE NO = 74,0000
- DEVELOPED SC5 CURVE NO = 98,0000
- 1. SELECT DESIGN STORM: 100 YEAR, 24-HOUR: 9.30
- 2. TYPE OF SUBSURFACE DISPOSAL SYSTEM: PRECAST DRYWELL WITH 3-5/4 CRUSHED STONE
- 3. DETERMINE PERCOLATION RATE: PERCOLATION RATE: 1.0000 INCHES/50.0000 MINUTES
- 4. AREA OF PERCOLATION (AP): SURFACE AREA OF CYLINDER AC=PI*D*H*V.G
- 5. CALCULATE VOLUME PER DRYWELL: VW=PI*R²*HEIGHT
- 6. CALCULATE 24-HOUR PERCOLATION VOLUME PER DRYWELL (VP): VP=SIDE SURFACE AREA OF DRYWELL*SOIL PERCOLATION RATE(SR)
- 7. CALCULATE THE TOTAL 24-HOUR VOLUME PER DRYWELL (VT): VT=VOLUME OF DRYWELL(VW)/PERCOLATION VOLUME(VP)
- 8. DETERMINE NUMBER OF DRYWELLS REQUIRED (DNR): DNR=TOTAL VOL. PER DRYWELL(VT)/DNR=1.9493

STABILIZED CONSTRUCTION ENTRANCE

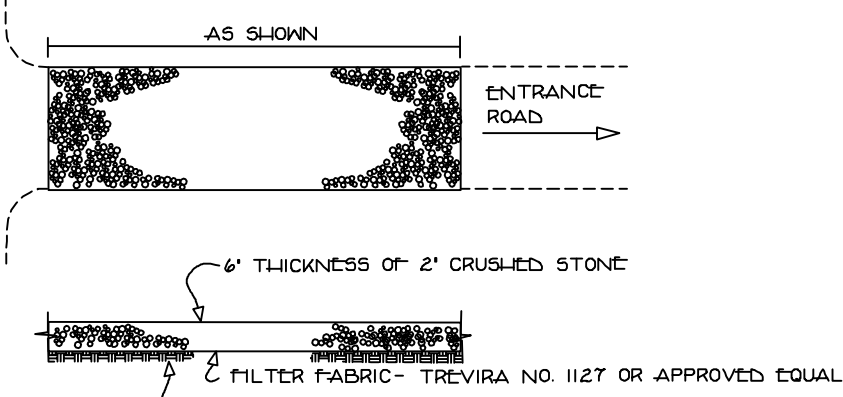

GRAPHIC SCALE

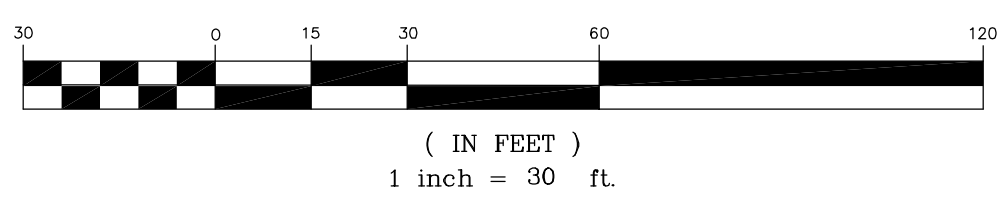

NOTES CONT'D:

- ALL ROOF LEADERS TO BE DISCHARGED TO THE DRYWELLS.
- AREA OF DISTURBANCE-9500 SF.
- PERCOLATION TEST TO BE PERFORMED PRIOR TO FINAL APPROVAL.
- AS PER ROBERT TORGERSEN, THERE ARE NO WETLANDS LOCATED ON SITE. ACCORDING TO FEMA MAPS THERE IS NO FLOODPLAIN LOCATED ON SITE.
- NO WATER SUPPLY IMPROVEMENTS ARE NECESSARY.
- LOT DRAINAGE SHOWN SHALL CONSTITUTE EASEMENTS RUNNING WITH THE LAND & SHALL NOT BE DISTURBED.
- ALL UTILITIES INCLUDING ELECTRIC & TELEPHONE SERVICE SHALL BE INSTALLED UNDERGROUND.
- THIS PLAN DOES NOT CONFLICT WITH THE COUNTY OFFICIAL MAP & HAS BEEN APPROVED IN THE MANNER SPECIFIED BY SECTION 259 L & M OF THE GENERAL MUNICIPAL LAW OF THE STATE OF NEW YORK.
- ELEVATION DATUM IS GPS DERIVED NAVD88. SITE BENCHMARK IS RIM ELEVATION OF 152.0 OF SANITARY SEWER MANHOLE ON ADJACENT TAXLOT #6918-3-431.
- CROSSING OF THE EXISTING SANITARY SEWER EASEMENT BY MACHINERY MUST ONLY OCCUR OVER THE DEFINED STEEL PLATED AREA (SEE DETAIL). THE SIZE OF THE STEEL PLATING SHALL BE AS PER DETAIL OR A.O.B.E. ONCE CROSSING MACHINERY HAS BEEN DETERMINED. ONCE THE CROSSING MACHINERY HAS BEEN DETERMINED, THE FINAL STEEL PLATE DESIGN SHALL BE SUBMITTED TO THE DEPARTMENT OF ENVIRONMENTAL MANAGEMENT AND ENGINEERING FOR REVIEW AND APPROVAL. NO CONSTRUCTION FILL SHALL BE PLACED OVER EASEMENT UNTIL THE FINAL CROSSING DETAILS AND PLATE DESIGN HAVE BEEN REVIEWED AND APPROVED BY THE DENE. THE APPLICANT SHALL CONTACT THE TOWN OF ORANGETOWN'S SEWER INSPECTOR TO COORDINATE THE CROSSING OF THE SEWER EASEMENT.
- THE APPLICANT/BUILDER/SITE OPERATOR SHALL CONTACT THE TOWN SEWER INSPECTOR AT LEAST 48 HOURS PRIOR TO ANY WORK BEING PERFORMED IN OR AROUND THE EXISTING SANITARY SEWER MAIN. THIS SHALL INCLUDE TELEVISIONING THE LINE, LANDSCAPING, INSTALLATION OF DRAINAGE PIPE, CROSSING THE SANITARY SEWER MAIN, INSTALLATION OF THE SANITARY SEWER CONNECTION, REGRADING, ETC.
- THE EXISTING SANITARY SEWER MAIN, WHICH CURRENTLY RUNS THROUGH THE PROPERTY, SHALL BE TELEVISIONED FROM THE EXISTING MANHOLE IN SUNRISE TO THE MANHOLE IN THE REAR ION LOT #6918-3-391. IT SHALL BE TELEVISIONED PRIOR TO CONSTRUCTION AND AFTER, IT SHALL BE TELEVISIONED UPON COMPLETION OF ALL THE IMPROVEMENTS TO ENSURE THAT NO DAMAGE IS DONE TO THE LINE DUE TO THE PROPOSED CONSTRUCTION. THE APPLICANT SHALL SUBMIT THE NAME OF THE COMPANY WHICH INTENDS TO PERFORM THE TELEVISIONING OF THE LINE TO THE TOWN OF ORANGETOWN FOR APPROVAL.
- THE APPLICANT OR THEIR REPRESENTATIVE SHALL COORDINATE THE 'TYPING' OF THE SANITARY SEWER MAIN WITH THE TOWN'S SEWER DEPARTMENT/INSPECTOR, SO THAT THE DEPARTMENT/INSPECTOR CAN WITNESS THE TELEVISIONING.

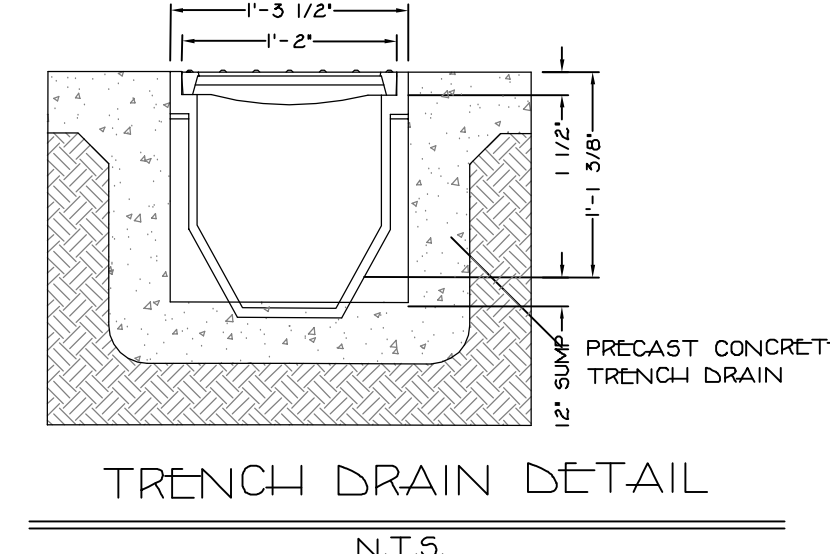
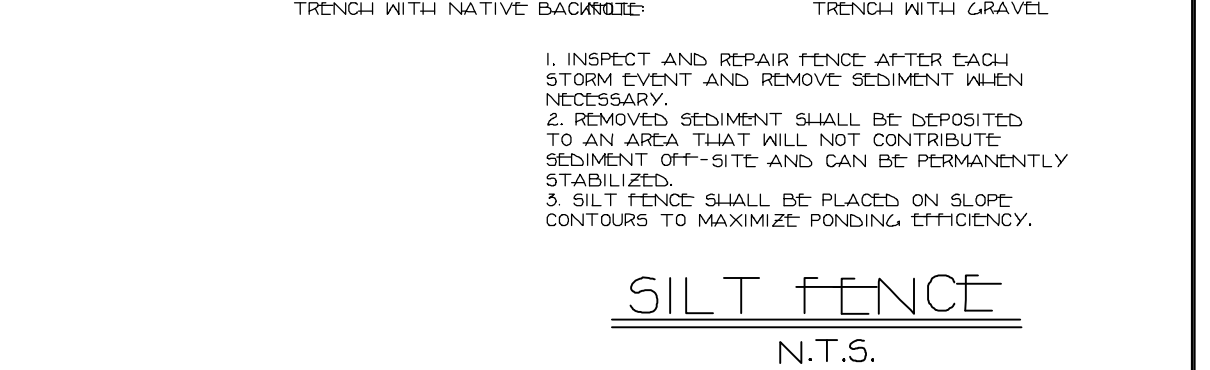
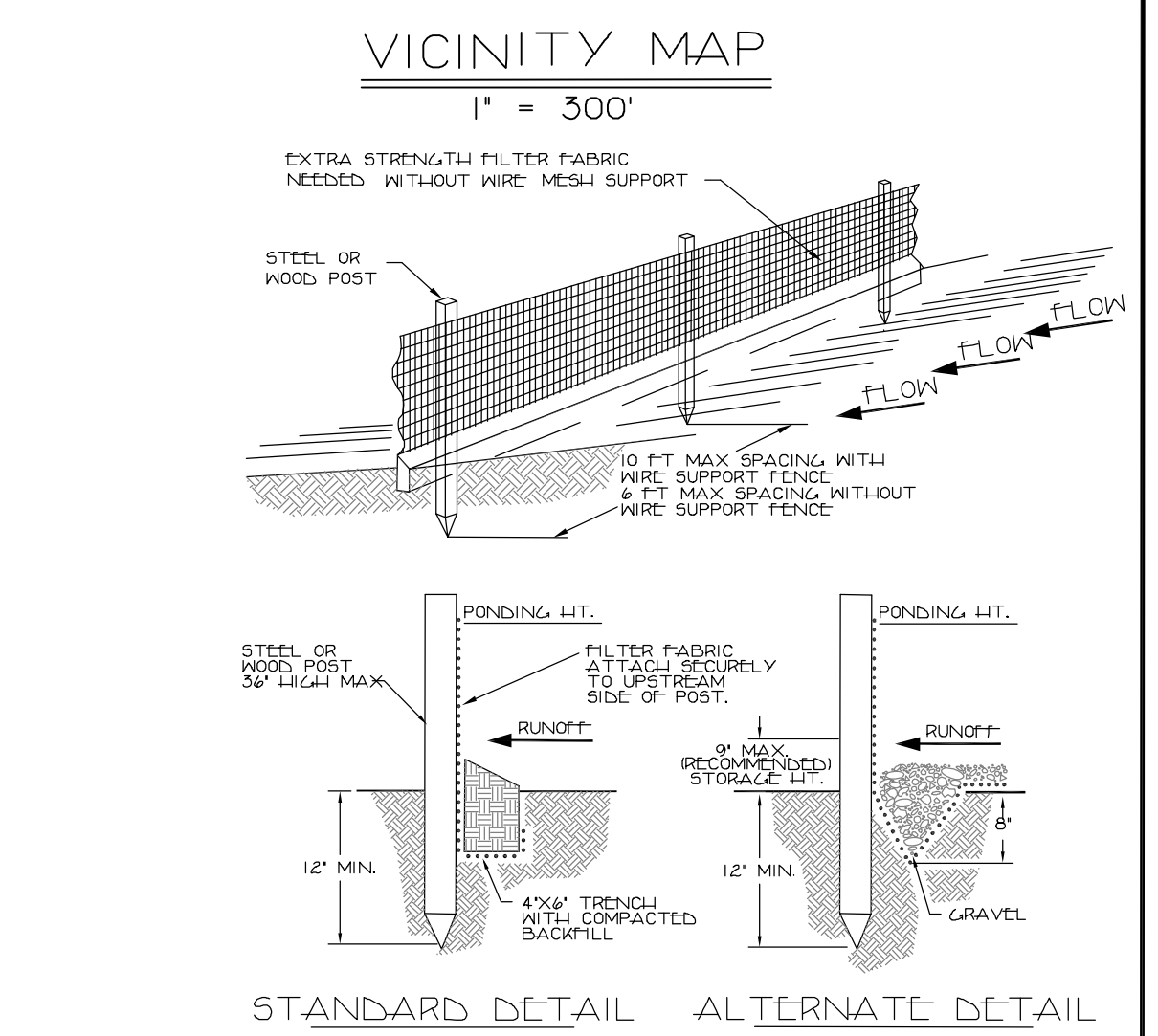
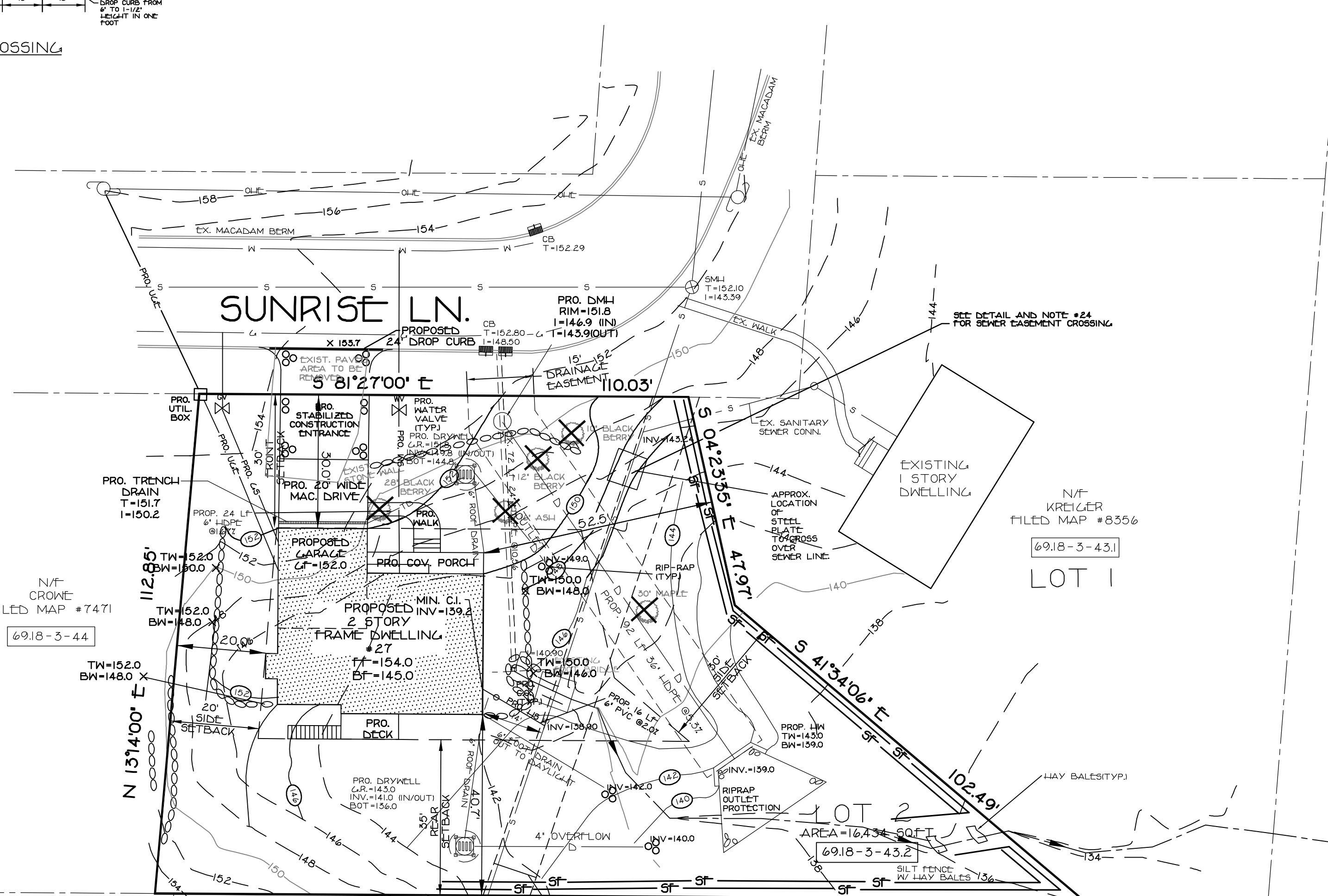
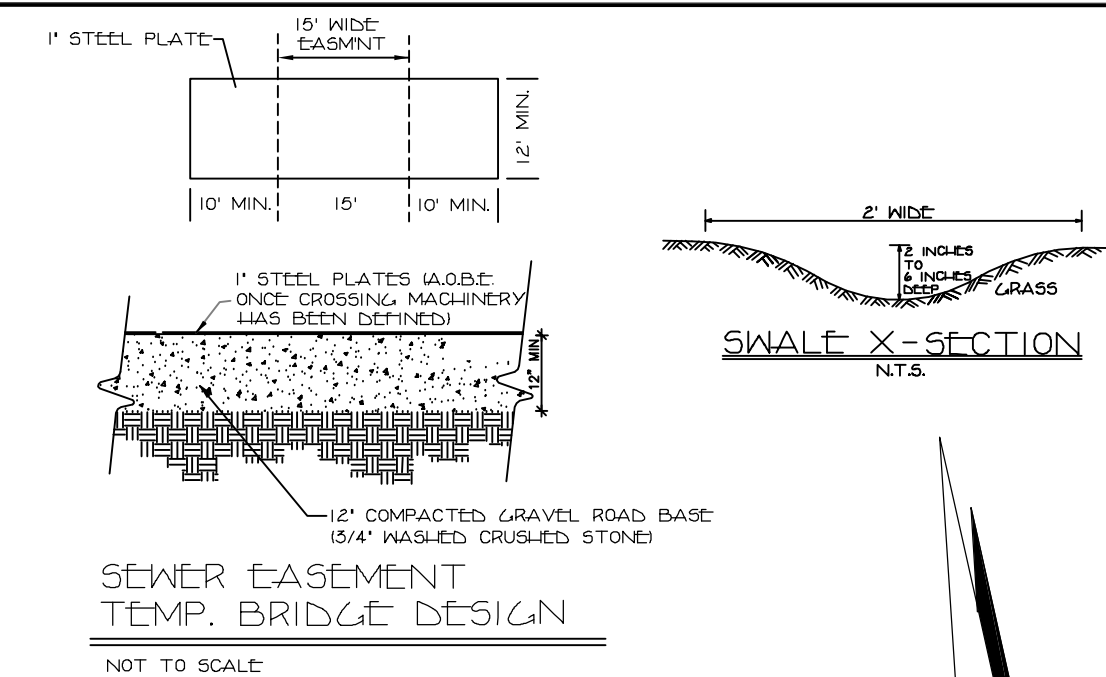

NOTE: PROVIDE 12\"/>

- 4-8-11-16 REVISE DRAINAGE
- 3-6-22-18 ADD WALL
- 2-5-24-18 REVISE AS PER COMMENTS
- 1-4-27-18 REVISE AS PER COMMENTS

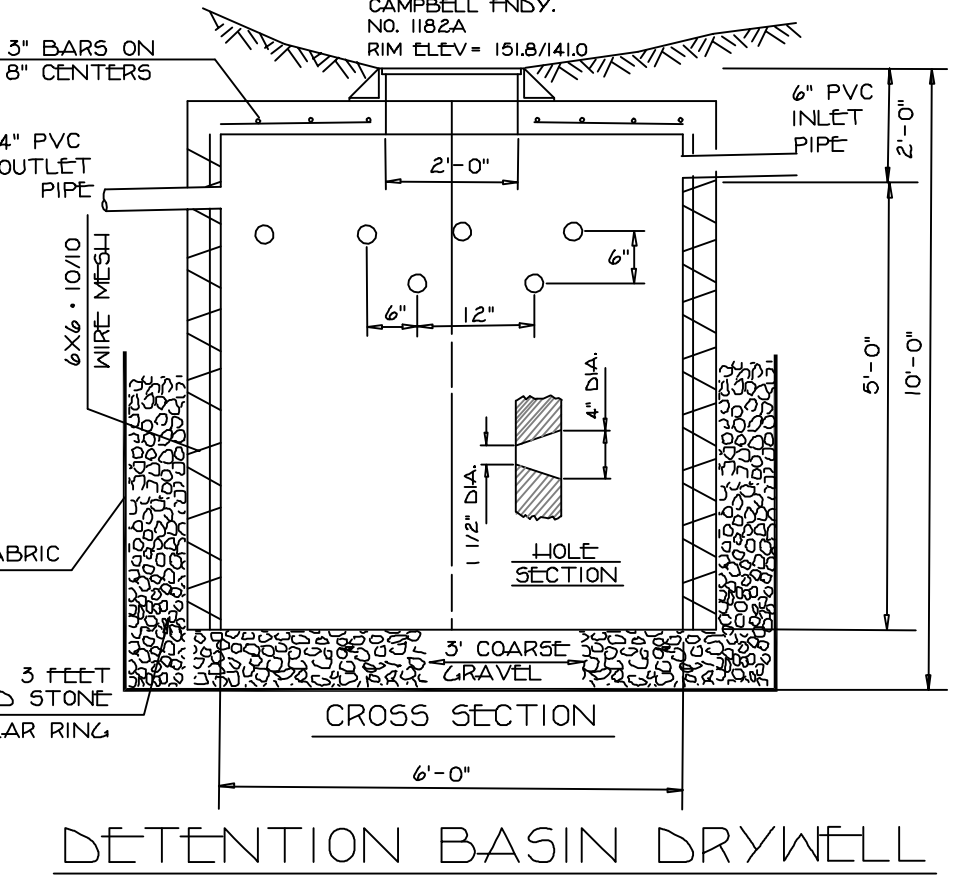

DETECTION BASIN DRYWELL

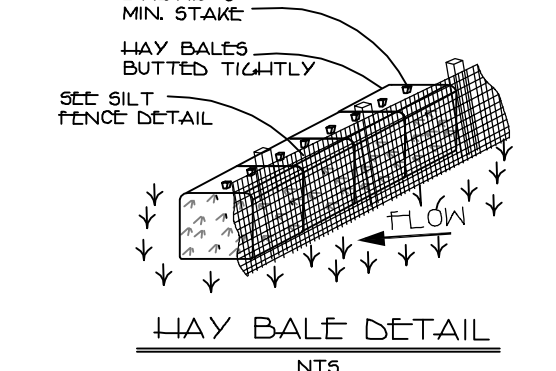

TAX MAP SECTION 69.18
BLOCK 3, LOT 43.2
PLOT PLAN
FOR
KREIGER ESTATE
27 SUNRISE LANE
HAMLET OF PEARL RIVER
TOWN OF ORANGETOWN
ROCKLAND COUNTY, NEW YORK

PAUL GDANSKI P.E., PLLC
25 RIVERSIDE DRIVE
SUFFERN, N.Y. 10901
TEL: (917) 418-0999

275UNRISE
JAN. 06, 2018
1\"/>



1 FRONT ELEVATION
SCALE: 1/4" = 1'-0"



2 RIGHT ELEVATION
SCALE: 1/4" = 1'-0"



3 REAR ELEVATION
SCALE: 1/4" = 1'-0"

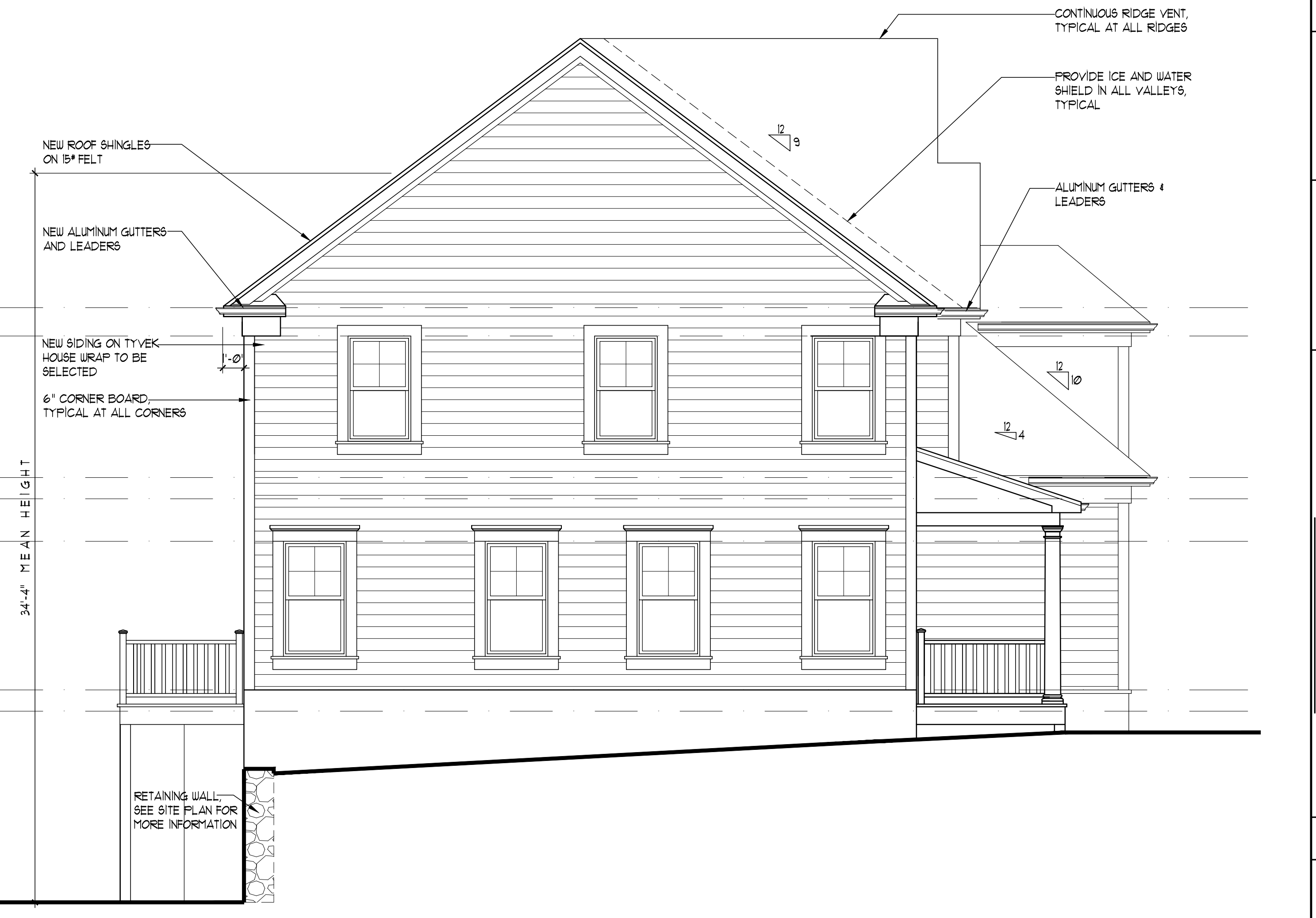

4 LEFT ELEVATION
SCALE: 1/4" = 1'-0"

date	issue	description
02-08-2018	A	ISSUED FOR PERMIT
07-11-2018	B	BUILDING MEAN HEIGHTS

ELEVATIONS
NEW RESIDENCE
SUNRISE LANE LOT # 2
ORANGETOWN, NEW YORK

DRAWN	CHECKED	DATE	SCALE
FN	ROBERT HOENE	3-5-2013	AS NOTED

ROBERT HOENE, AIA	
<input type="checkbox"/> Colorado	402808
<input type="checkbox"/> Connecticut	7640
<input type="checkbox"/> Florida	91918
<input type="checkbox"/> New Jersey	09507
<input checked="" type="checkbox"/> New York	017612

ROBERT HOENE
ARCHITECT
— A.I.A. —
379 PIERMONT AVENUE
PIERMONT, NEW YORK 10968
(845) 359-6723 www.hoenearchitects.com

JOB# 1805
A1.0
1 of 3

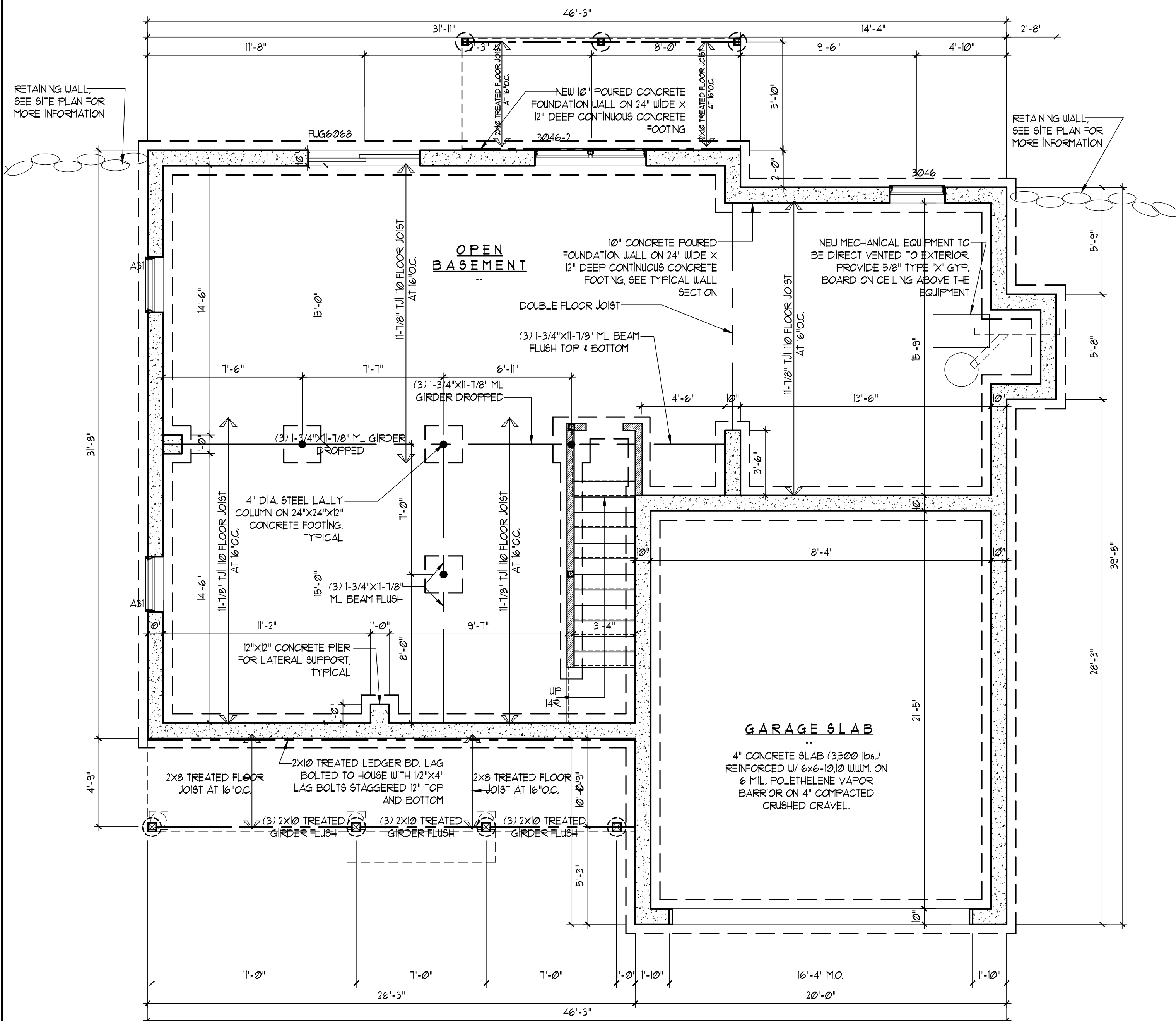

1 BASEMENT / FOUNDATION FLOOR PLAN
SCALE: 1/4" = 1'-0"

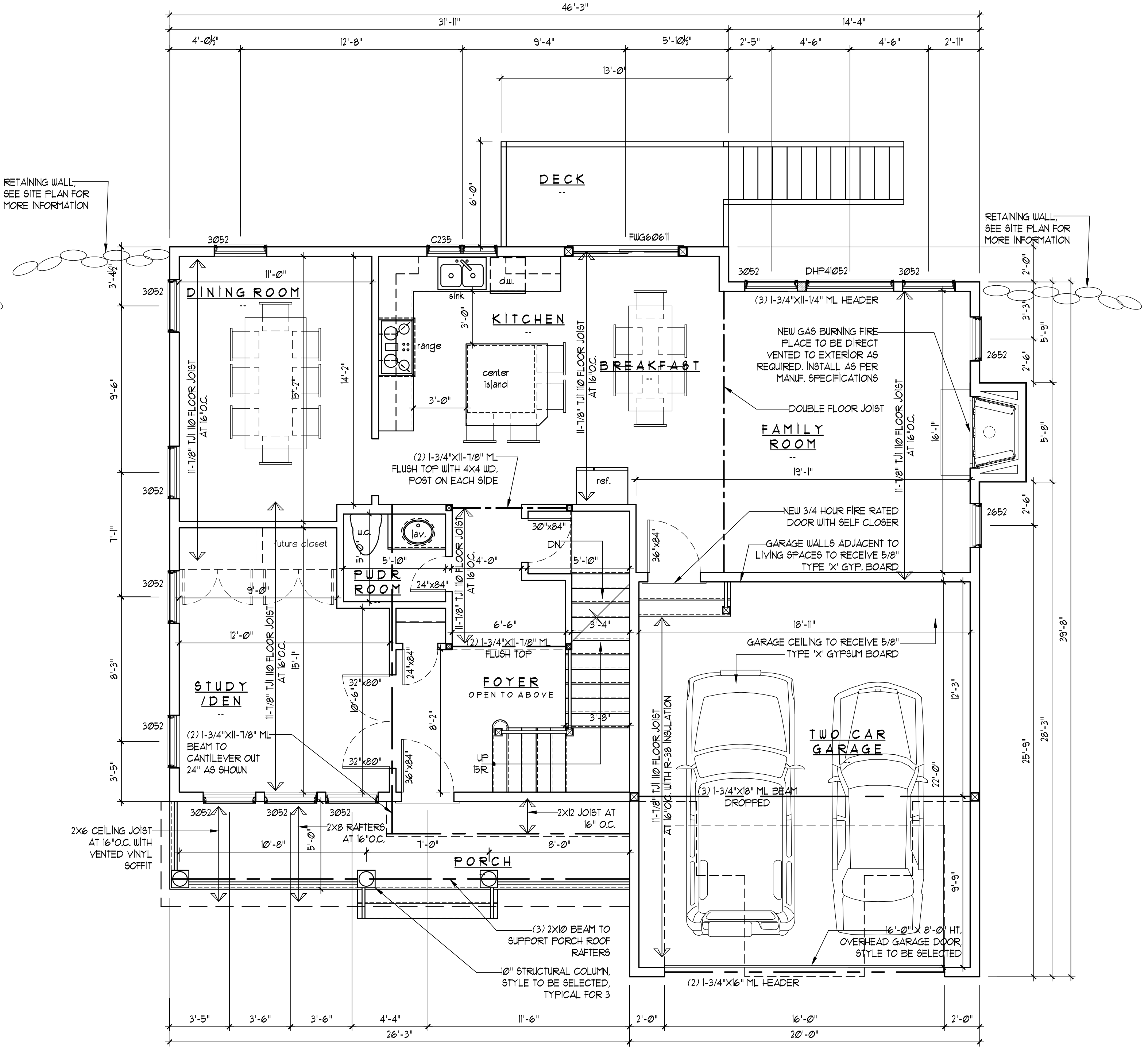

2 FIRST FLOOR PLAN
SCALE: 1/4" = 1'-0"

date	issue	description	by
02-08-2018	A	ISSUED FOR PERMIT	FN

FOUNDATION PLAN & FIRST FLOOR PLAN
NEW RESIDENCE
SUNRISE LANE LOT #2
ORANGETOWN, NEW YORK

DRAWN:	FN
CHECKED:	ROBERT HOENE
DATE:	3-5-2013
SCALE:	AS NOTED

ROBERT HOENE, AIA

- Colorado 402808
- Connecticut 7640
- Florida 91918
- New Jersey 09507
- New York 017612

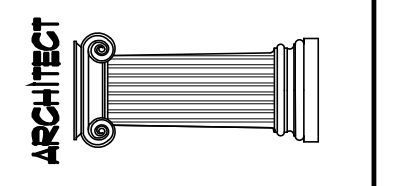

ROBERT HOENE
ARCHITECT
—A.I.A.—
379 PIERMONT AVENUE
PIERMONT, NEW YORK 10968
(845) 359-6723 www.hoenearchitects.com

JOB# 1805

A2.0

GENERAL NOTES

- GENERAL:**
 1. All work performed shall comply with all requirements of the New York state building and energy code.
 2. Contractor to verify all dimensions and conditions prior to starting construction. Any discrepancies shall be reported to the architect.
 3. It shall be understood that the scope of these drawings, include only basic structural and architectural information and that no further liability will be assumed beyond the contents of these signed and sealed documents.
 4. For design purposes, load values for these plans were taken from Table R401.4 under "sand sily sand, clayey sand, silty gravel, and clayey gravel" having a minimum load bearing pressure of 2000 PSF. Site with soil values appearing less than 2000 lbs shall be tested to locate virgin soil with approved bearing value prior to footing installation. Garage slabs are to be 3500 lbs as per table R402.2. The architect shall be notified of these findings for redesign of footings, foundation and slab where applicable.
 5. All concrete work shall be transit mixed concrete developing a strength of 3000 PSI at 28 days.
 6. All lumber shall be sound dry material. All lumber shall be construction grade Douglas fir or KD Spruce with the following min. stress: Fb+ 1500 PSI, and E+ 1700000.
 7. All electrical work shall conform to the requirements of the NECA and the local utility company.
 8. All plumbing work shall conform to all state and local codes.
 9. All heating work shall conform to all state and local codes.
 10. The contractor shall be responsible to notify the architect and the owner in case of any discrepancies between removal noted on the drawings, and that which would be required for completion of the project or that might jeopardize the structural integrity of the building. All structure shall be carefully supported throughout the removal of any bearing walls, so that the building experiences no loss of integrity.
 11. Headers over all doors, windows, and other openings under 6'-0" shall be (2) 2x10 (unless otherwise noted. Header openings 6' to 8' shall receive (3) 2x10 or (2) 2x12 headers in exterior walls unless otherwise noted.
 12. Provide double floor joist below parallel partitions.
 13. Install CO2 detectors as required by code.
SMOKE DETECTORS:
 Provide smoke detectors (hard wired) in all bedrooms, hall areas (near bedrooms), attic, and basement.
 Installation to meet all codes. Provide carbon monoxide detectors in location as required by code.
BUILDING THERMAL ENVELOPE REQUIREMENTS:
 The building thermal envelope shall be sealed to limit infiltration. Refer to section N102.41 of the "NEW YORK STATE RESIDENTIAL CODE" regarding areas requiring caulking, weatherstripping, 4 or other suitable air barrier materials.
VAPOR RETARDERS:
 "NEW YORK STATE RESIDENTIAL CODE" N102.5 Class 1 (Rockland County NY + Zone 5)
 Provide sheet polyethylene, non-perforated aluminum foil on basement / garage stud walls.
STAIR NOTES:
 TYPICAL EXTERIOR STAIR / HANDRAIL REQUIREMENTS (MEET NEW YORK STATE CODE REQUIREMENTS):
 1. Max Riser height 8-1/4 inches.
 2. Minimum tread depth 9 inches. Minimum nosing 3/4 inch.
 3. Handrails 36" AFF. (above finished floor).
 4. Spindle spacing to be 4" O.C. (on center).
 N101.4 - ZONE 5 (ROCKLAND COUNTY, NY) - N101.5 - addressed in energy calculations (rescheck).
 N102.5.3 - All minimum clear air spaces and vented openings for vented cladding shall comply.
 N103 - All systems shall comply with this section.
 M401.3 - All mechanical information shall be provided by the mechanical contractor.
NEW YORK STATE ENERGY EFFICIENCY RELATED REQUIREMENTS FOR DETACHED ONE AND TWO FAMILY DWELLINGS
 THIS RESIDENCE AND OR ADDITION WAS DESIGNED TO COMPLY WITH THE LATEST ENERGY CONSERVATION CODE 2015 WITH 2011 ENERGY CODE SUPPLEMENTS
TABLE N102.1 CLIMATE ZONE 5

LOCATION	PERFORMANCE REQUIRED	PERFORMANCE PROVIDED
CEILING	R-25	R-35
FLOOR	R-20	R-30
GLAZING	U-35	U-35
BASEMENT WALL	R-15	R-15
SLAB EDGE (ON GRADE)	R-10	NOT APPLICABLE
CRACK SPACE	R-5	NOT APPLICABLE

TABLE R 302.1(1)

ground snow load (psf)	wind design	subject to damage from	ice barrier	flood	air	mean
30 psf / 1.0 kN/m²	topographic effects	roof line	required	hazardous	nodes	annual temp
30 psf / 1.0 kN/m²	30 psf / 1.0 kN/m²	30 psf / 1.0 kN/m²	30 psf / 1.0 kN/m²	30 psf / 1.0 kN/m²	30 psf / 1.0 kN/m²	30 psf / 1.0 kN/m²

BUILDING CODE:
 Current 2015 International Residential Code and 2015 International Building Code of New York State with 2011 uniform construction code supplements New York State
 Current 2015 Energy Conservation Code of New York State with 2011 energy code supplements

STRUCTURAL DESIGN LOADING:
 Drawings are designed to comply per these requirements.
TABLE R301.5

Attic:	20 lbs/sf LL + 10 lbs/sf DL = 30 PSF.
Exterior Balconies:	60 lbs/sf LL + 10 lbs/sf DL = 70 PSF.
Fire Escapes:	40 lbs/sf LL + 10 lbs/sf DL = 50 PSF.
Guardrail 4 handrails:	200 lbs/sf LL + 10 lbs/sf DL = 210 PSF.
Guardrail in fill comp.:	50 lbs/sf LL + 10 lbs/sf DL = 60 PSF.
Passenger vehicle garages:	20 lbs/sf LL + 10 lbs/sf DL = 30 PSF.
Rooms other than sleeping rms.:	40 lbs/sf LL + 10 lbs/sf DL = 50 PSF.
Sleeping rooms:	30 lbs/sf LL + 10 lbs/sf DL = 50 PSF.
Stairs:	40 lbs/sf LL + 10 lbs/sf DL = 50 PSF.
Deck:	40 lbs/sf LL + 10 lbs/sf DL = 50 PSF.

TABLE R301.6

ROOF SLOPE	tributary loaded area in square feet for any structural member
Flat or rise less than 4" per foot (1:3)	0 to 200 201 to 600 over 600
Rise 4" per foot (1:3) to less than 12" per foot (1:1)	16 14 12
Rise 12" per foot (1:1) and greater	12 12 12

TABLE R301.7
 Rafters having slope greater than a 3/12 with no finished ceiling attached to rafters L/180
 Interior walls and partitions H/180
 Floors 4 Plastered ceilings L/360
 All other structural members L/240
 Exterior walls with plaster or stucco finish H/360

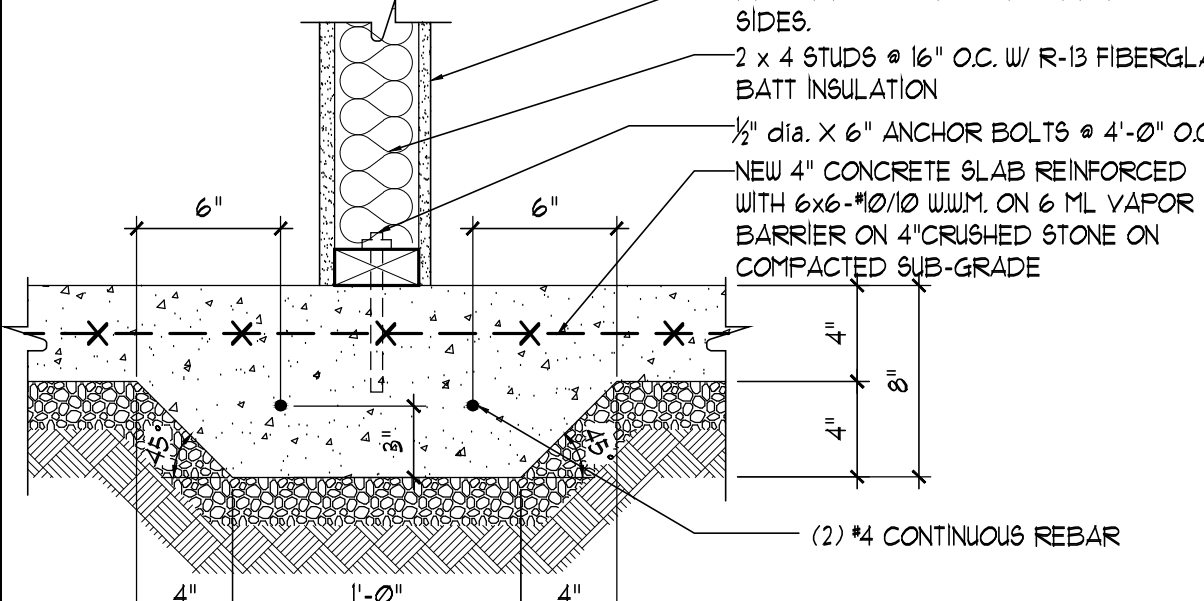

A DETAIL AT BEARING WALL SCALE: 1/2" = 1'-0"

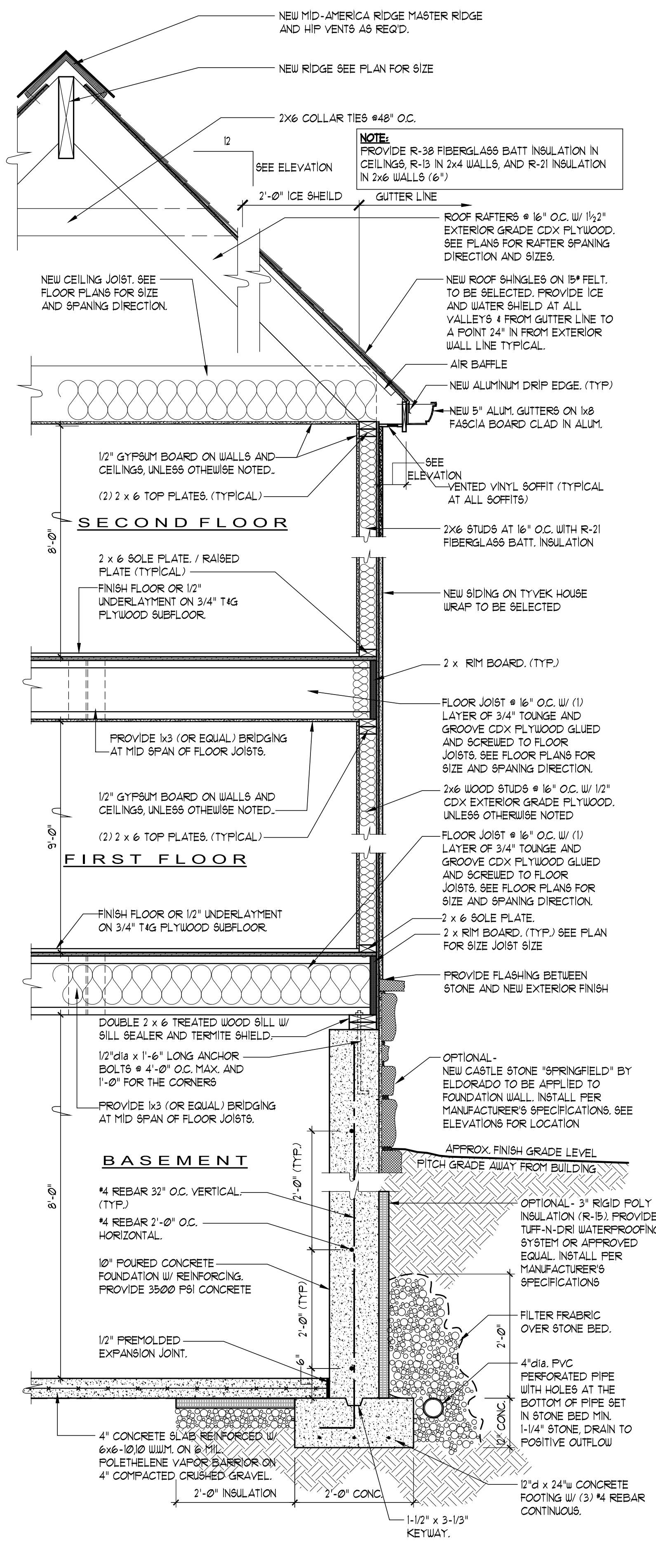

B TYPICAL WALL SECTION SCALE: 3/4" = 1'-0"

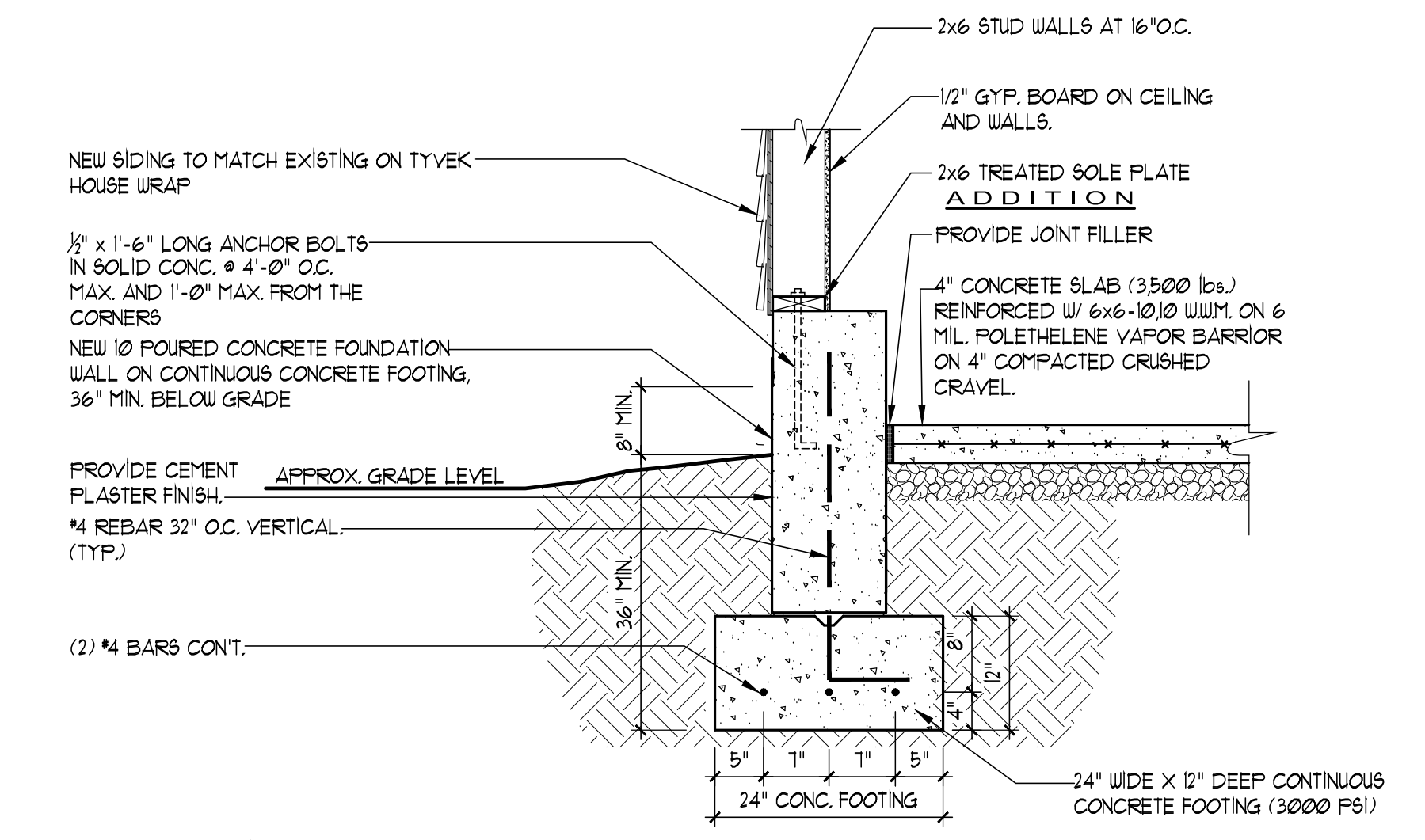

C SECTION THRU GARAGE SLAB SCALE: 3/4" = 1'-0"

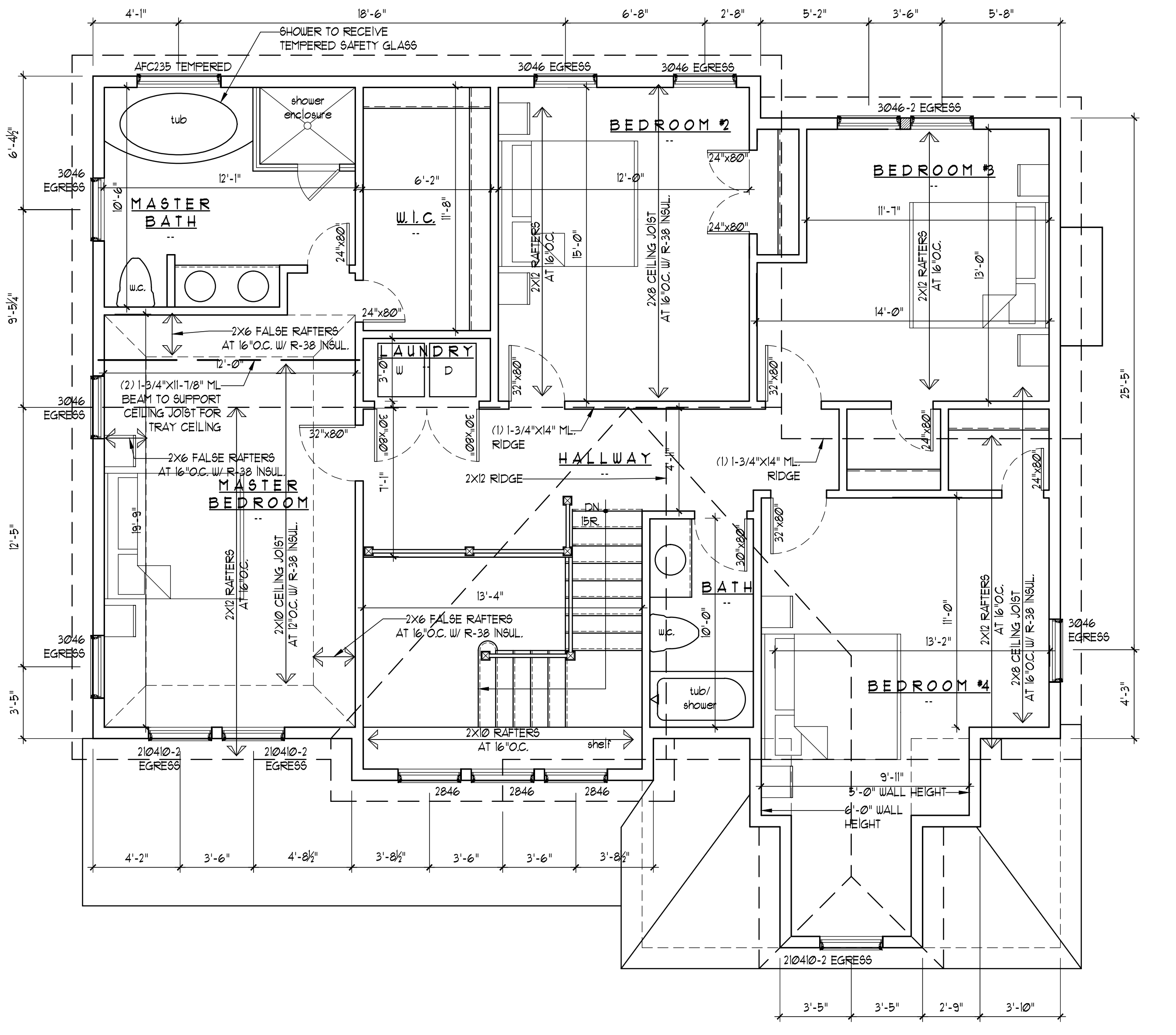

1 SECOND FLOOR PLAN SCALE: 1/4" = 1'-0"

date	issue	description
02-08-2018	1	ISSUED FOR PERMIT

GENERAL NOTES & SECOND FLOOR PLAN
NEW RESIDENCE
SUNRISE LANE LOT # 2
ORANGETOWN, NEW YORK

ROBERT HOENE, AIA
 DRAWN: FN
 CHECKED: ROBERT HOENE
 DATE: 02-08-2018
 SCALE: AS NOTED

- Colorado 402808
- Connecticut 7640
- Florida 91918
- New Jersey 09507
- New York 017612

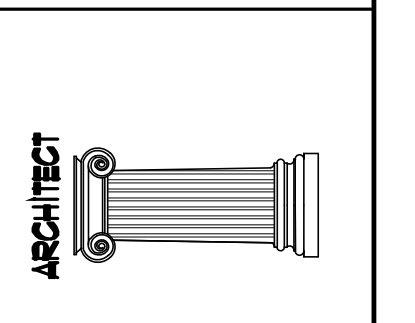

ROBERT HOENE
ARCHITECT
 — A.I.A. —
 379 PIERMONT AVENUE
 PIERMONT, NEW YORK 10968
 (845) 359-6723 www.lucarchitects.com

JOB# 1805
A3.0
 3 of 3

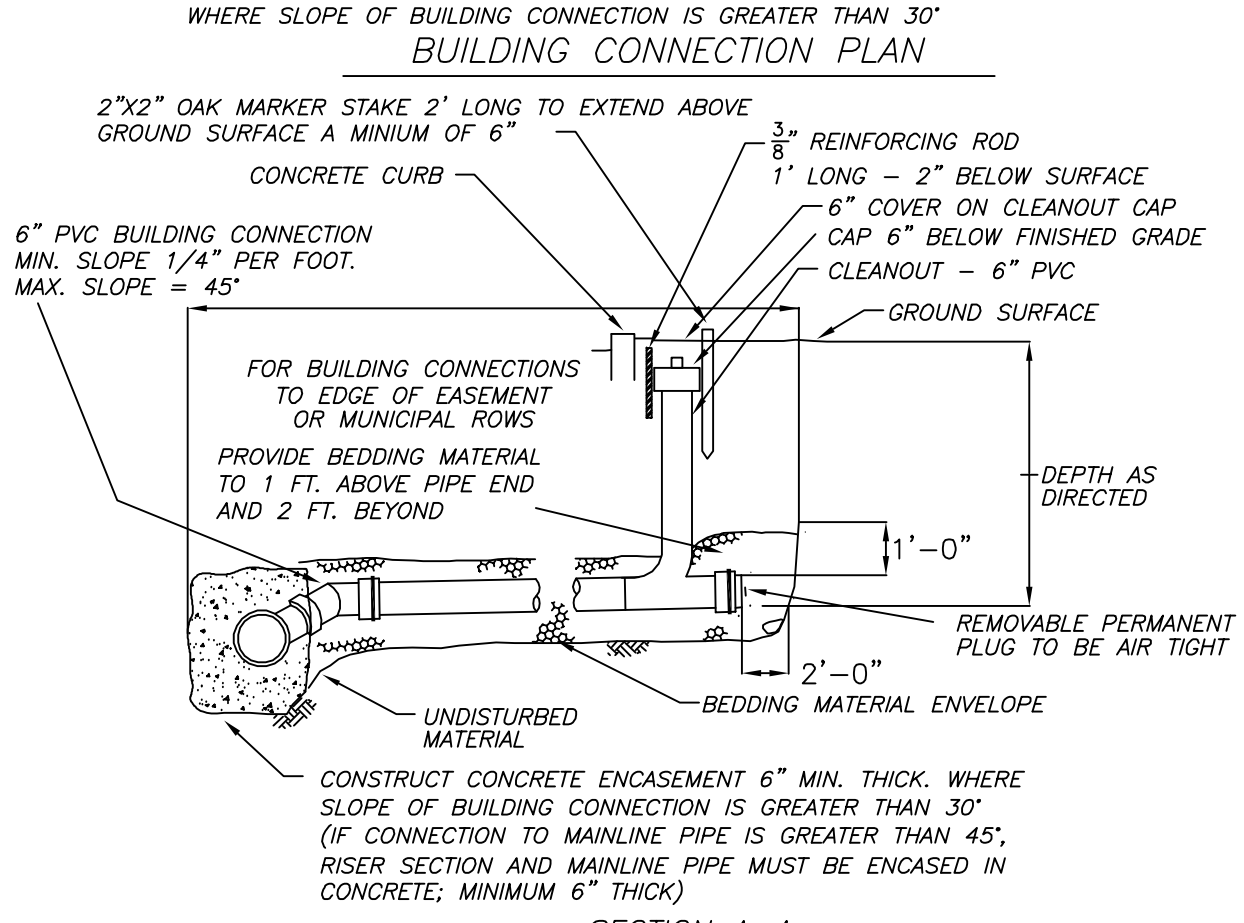
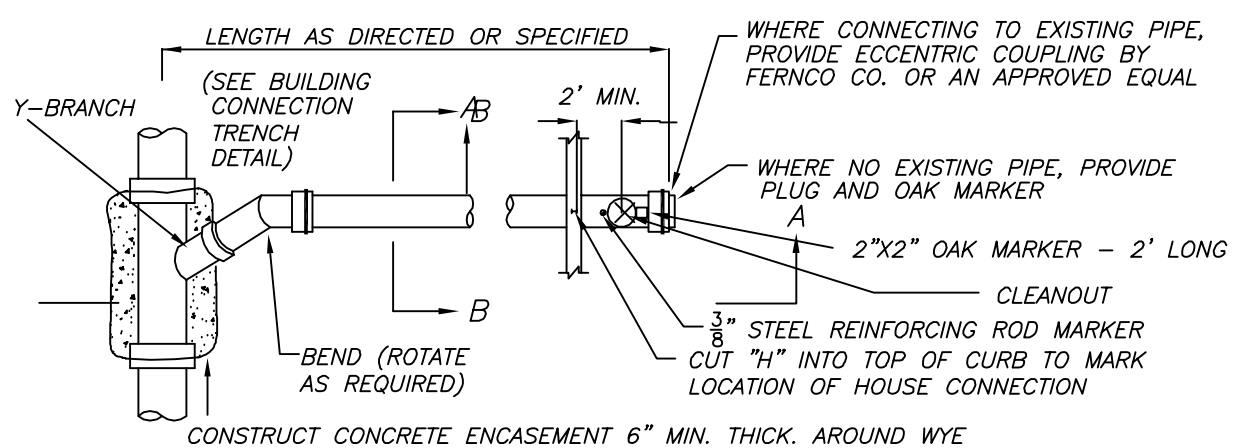

BUILDING CONNECTION ELEVATION
TOWN OF ORANGETOWN
BUILDING CONNECTION DETAIL
N.T.S.

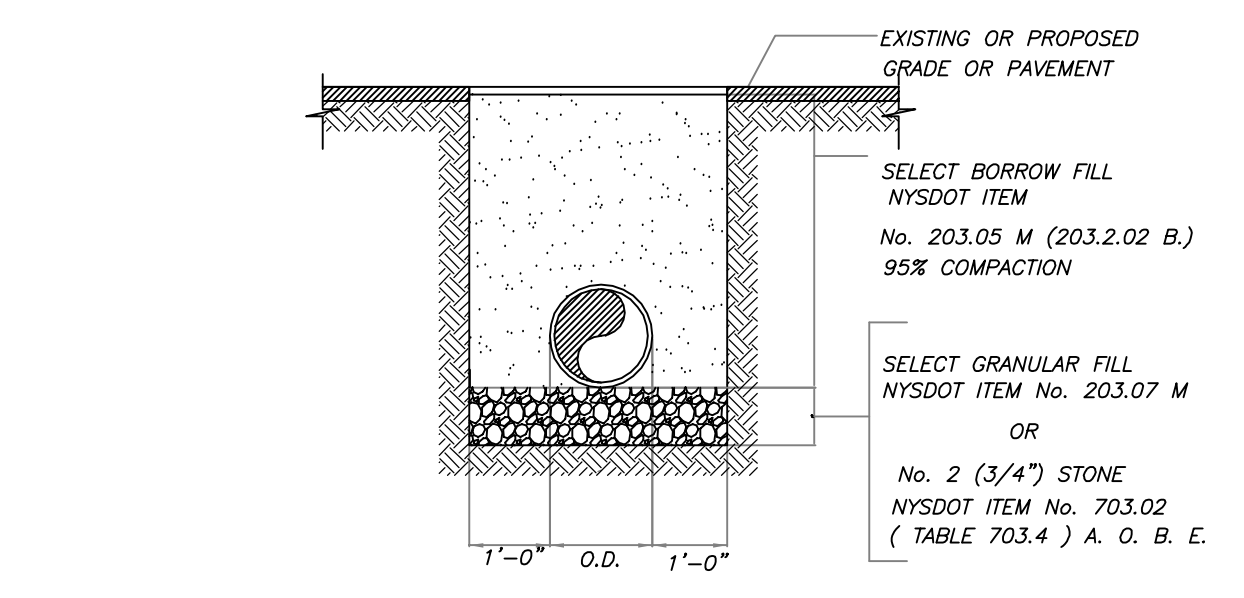

POLYETHYLENE PIPE ADS-N12 PIPE TRENCH DETAIL

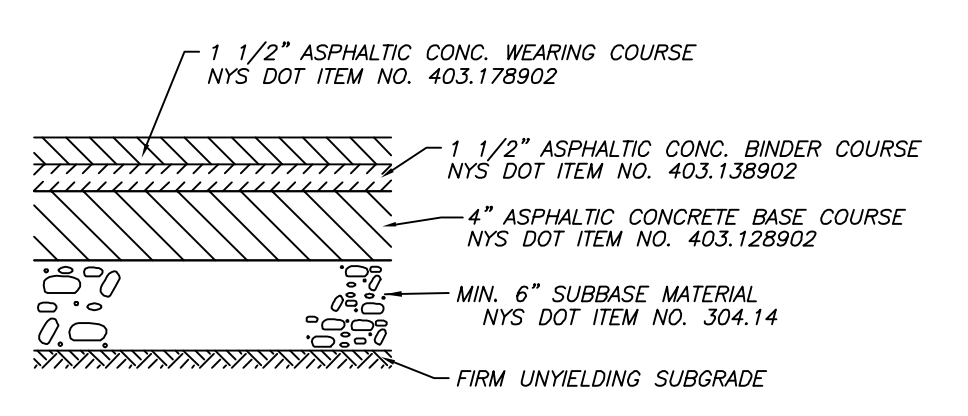

TYPICAL ROAD PAVEMENT DETAIL
N.T.S.
(PER ORANGETOWN SUBURBAN STREET SPECS)

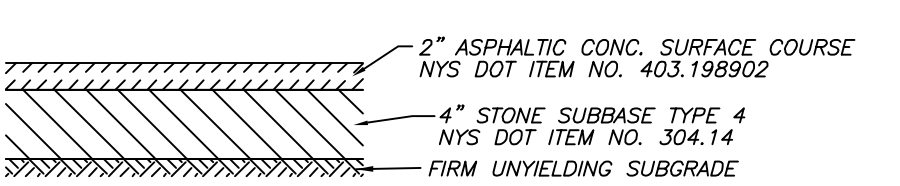

TYPICAL DRIVEWAY PAVEMENT DETAIL
N.T.S.

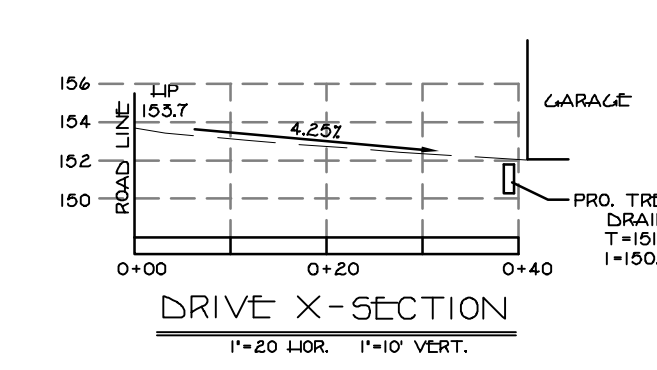

DRIVE X-SECTION
1"=20' HOR. 1"=10' VERT.

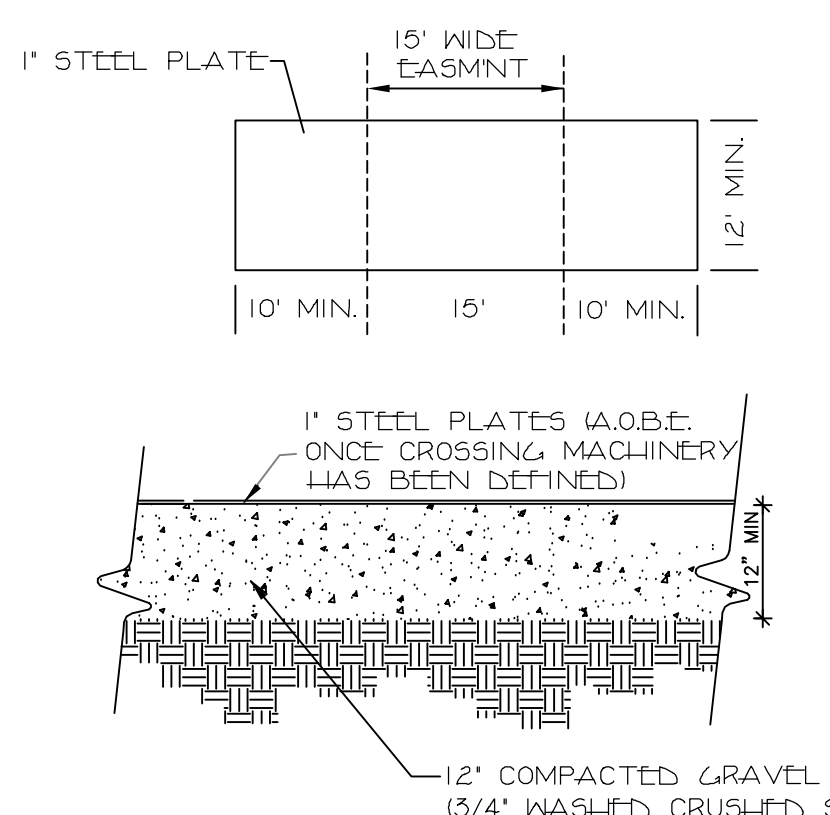

SEWER EASEMENT TEMP. BRIDGE DESIGN
NOT TO SCALE

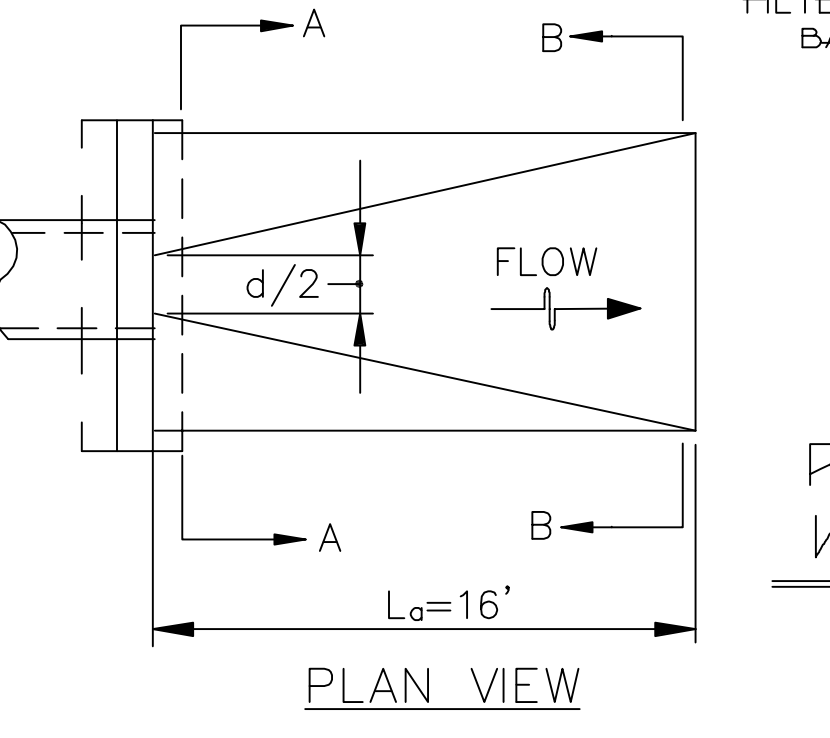

PLAN VIEW
N.T.S.

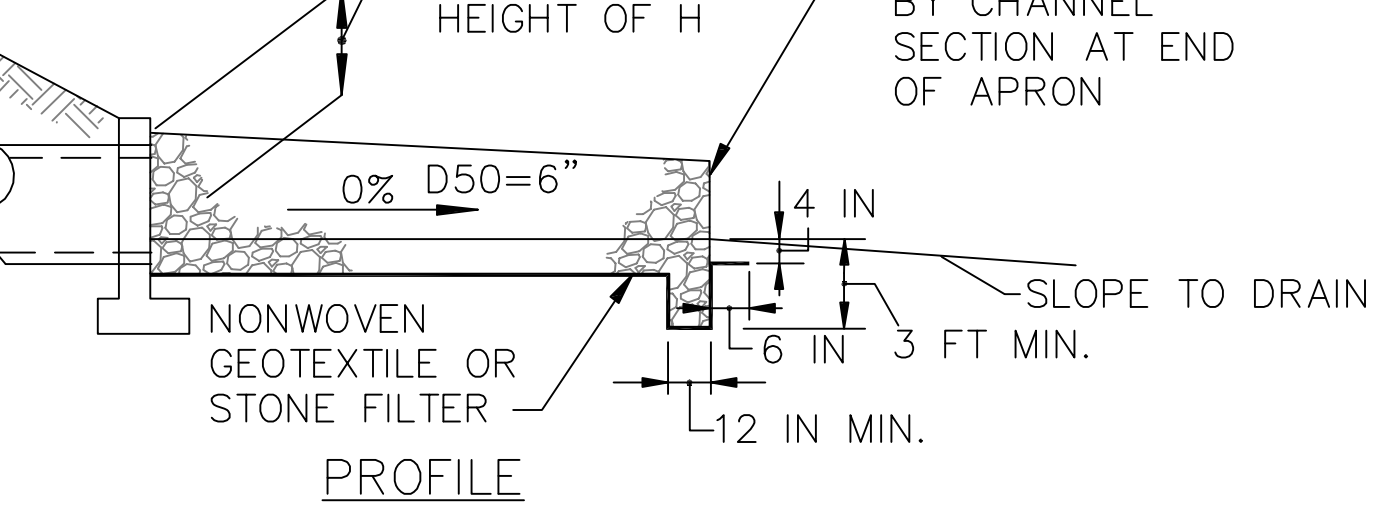

PROFILE

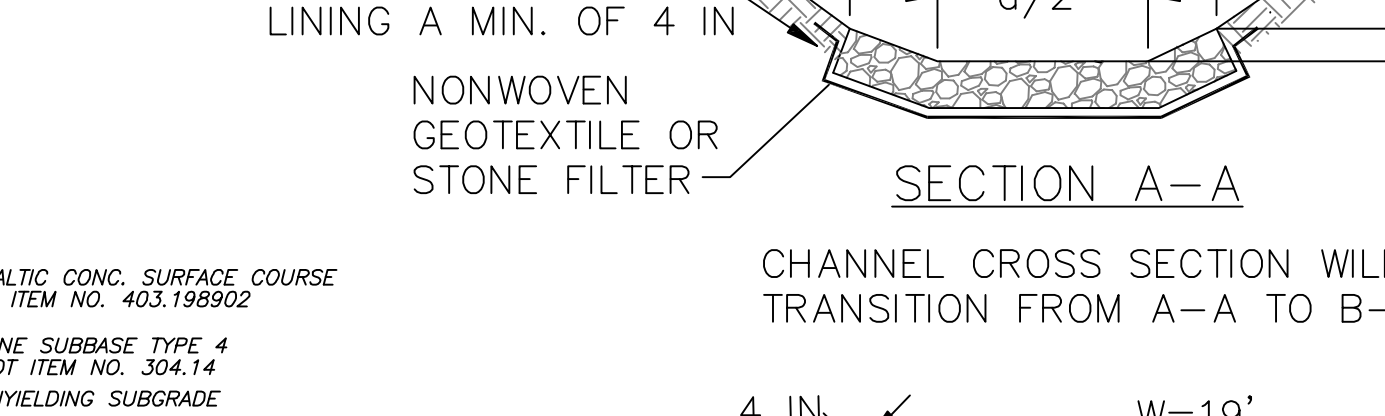

SECTION A-A
CHANNEL CROSS SECTION WILL TRANSITION FROM A-A TO B-B



SECTION B-B

RIPRAP	
CLASS	THICKNESS (T)
I	19 IN
II	32 IN
III	46 IN

ROCK OUTLET PROTECTION I

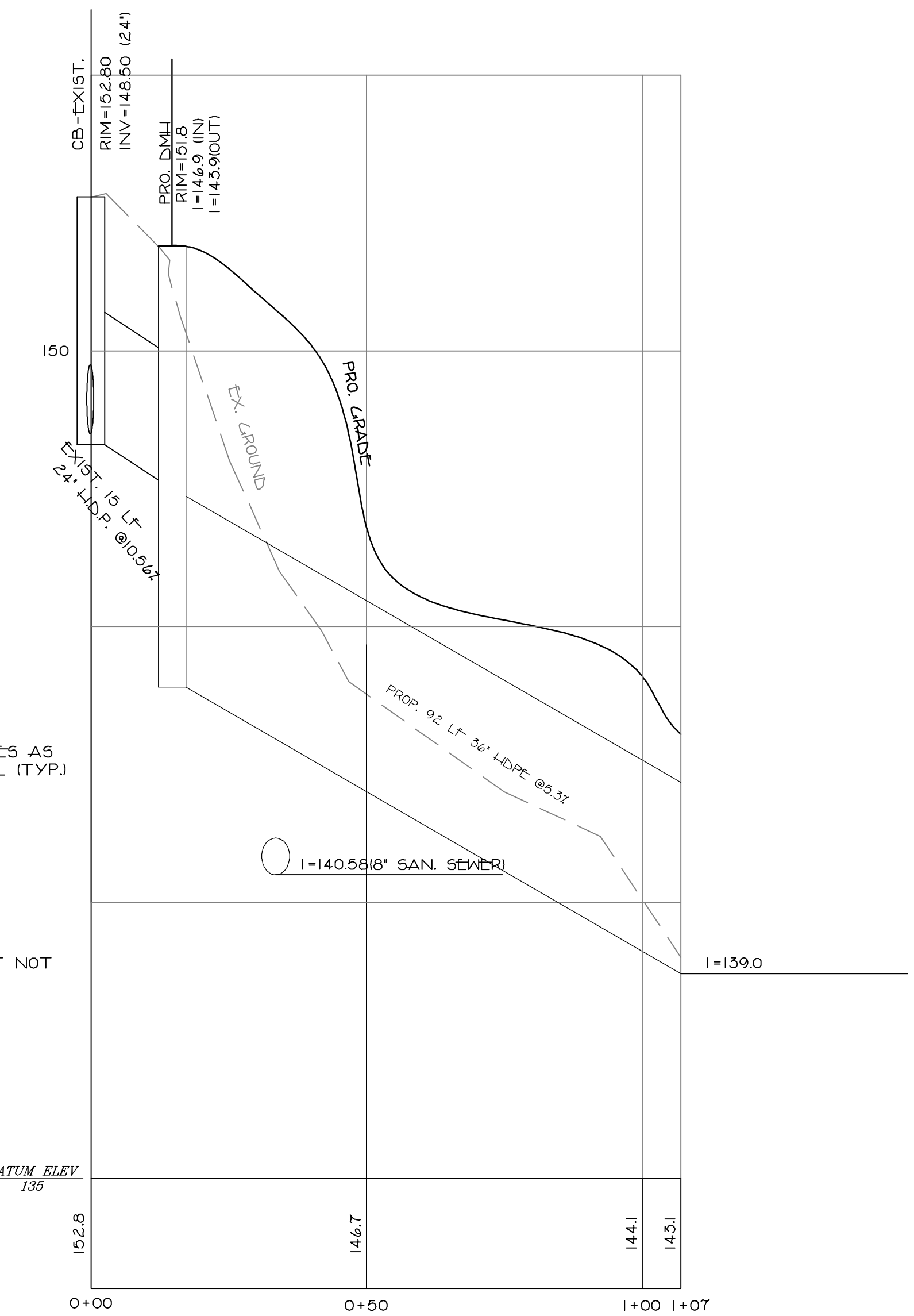

PROPOSED DRAINAGE PROFILE
1"=20' HOR. 1"=2' VERT.

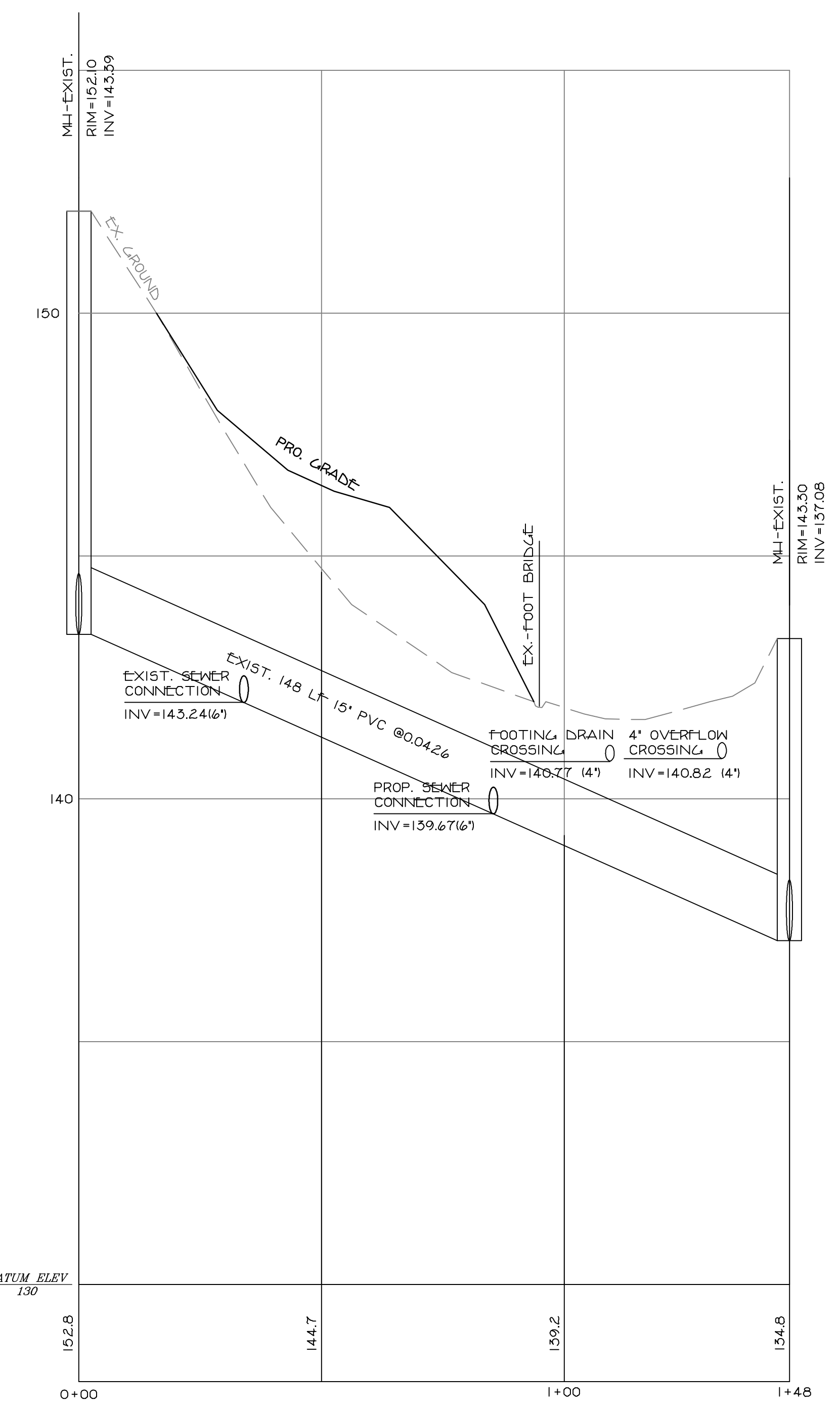

EXISTING SEWER PROFILE
1"=20' HOR. 1"=2' VERT.

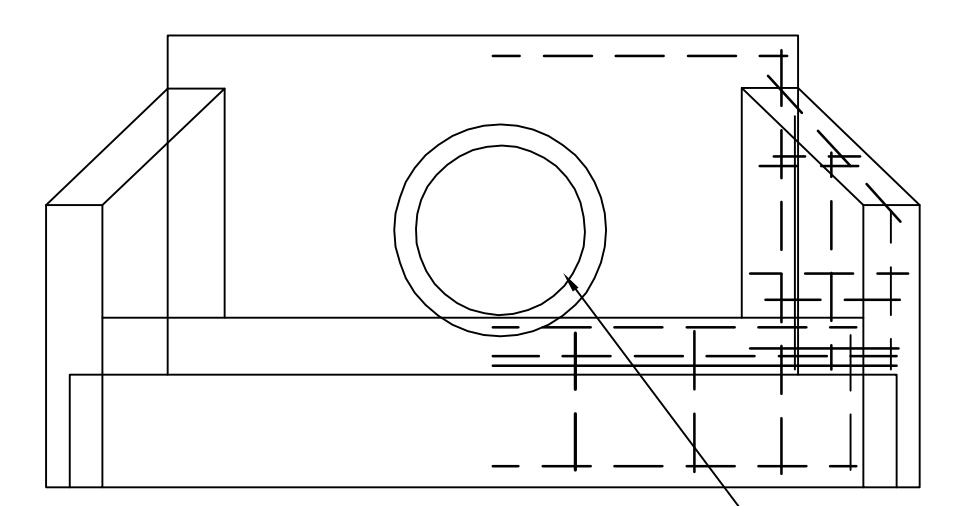

ELEVATION VIEW

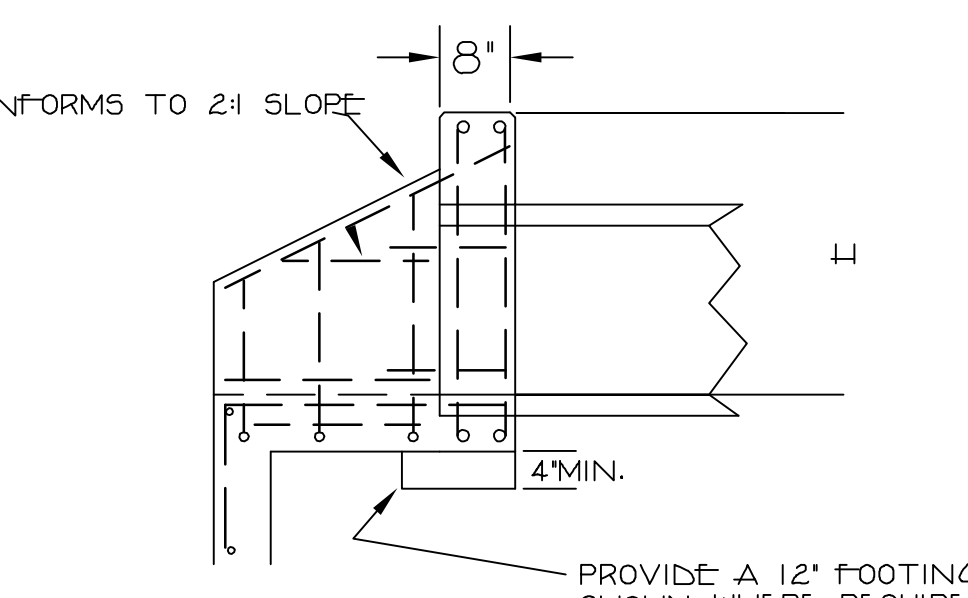

WING ELEVATION
CONCRETE HEADWALL DETAIL

NOTE:
1. SHIP DRAWINGS TO BE PROVIDED PRIOR TO INSTALLATION TO TOWN ENGINEER FOR REVIEW.
SCALE: N.T.S.

- 4-8-11-16 REVISE DRAINAGE
- 3-6-22-18 ADD WALL
- 2-5-24-18 REVISE AS PER COMMENTS
- 1-4-27-18 REVISE AS PER COMMENTS

TAX MAP SECTION 6918
BLOCK 3, LOT 43.2
PLOT PLAN
FOR
KREIGER ESTATE
27 SUNRISE LANE
HAMLET OF PEARL RIVER
TOWN OF ORANGETOWN
ROCKLAND COUNTY, NEW YORK

PAUL GDANSKI P.E., PLLC
25 RIVERSIDE DRIVE
SUFFERN, N.Y. 10901
TEL: (917) 418-0999

275UNRISE
JAN. 06, 2018
AS SHOWN
2 OF 2

UNAUTHORIZED ALTERATION OR ADDITION TO THIS PLAN IS A VIOLATION OF SECTION 7209(2) OF THE NEW YORK STATE EDUCATION LAW. COPIES OF THIS MAP NOT LEAVING THE SEAL OF THE SURVEYOR OR ENGINEER SHALL NOT BE VALID. CERTIFICATIONS ARE NOT TRANSFERABLE TO ADDITIONAL INSTITUTIONS OR SUBSEQUENT OWNERS. USE OF UNSEALED THIS DOCUMENT IN ANY COURT, TRANSACTION OR FILING WITH ANY OFFICE IS AN UNAUTHORIZED VIOLATION OF FEDERAL LAW.

PAUL GDANSKI
REGISTERED PROFESSIONAL ENGINEER
NO. 07590

PIPE CALCULATIONS

Prepared for

27 SUNRISE

TOWN OF ORANGETOWN
ROCKLAND COUNTY, NEW YORK

Paul Gdanski, PE, PLLC
25 Riverside Drive
Suffern, NY 10901



DATE: August 11, 2018

RAINFALL INTENSITY CURVES FOR ROCKLAND COUNTY, NEW YORK

STORM DURATIONS - 5 MINUTES TO 120 MINUTES
RETURN PERIODS - 2 YEARS TO 100 YEARS

NUSSBAUMER, CLARKE & VELZY
CONSULTING ENGINEERS

INTENSITY (INCHES PER HOUR)

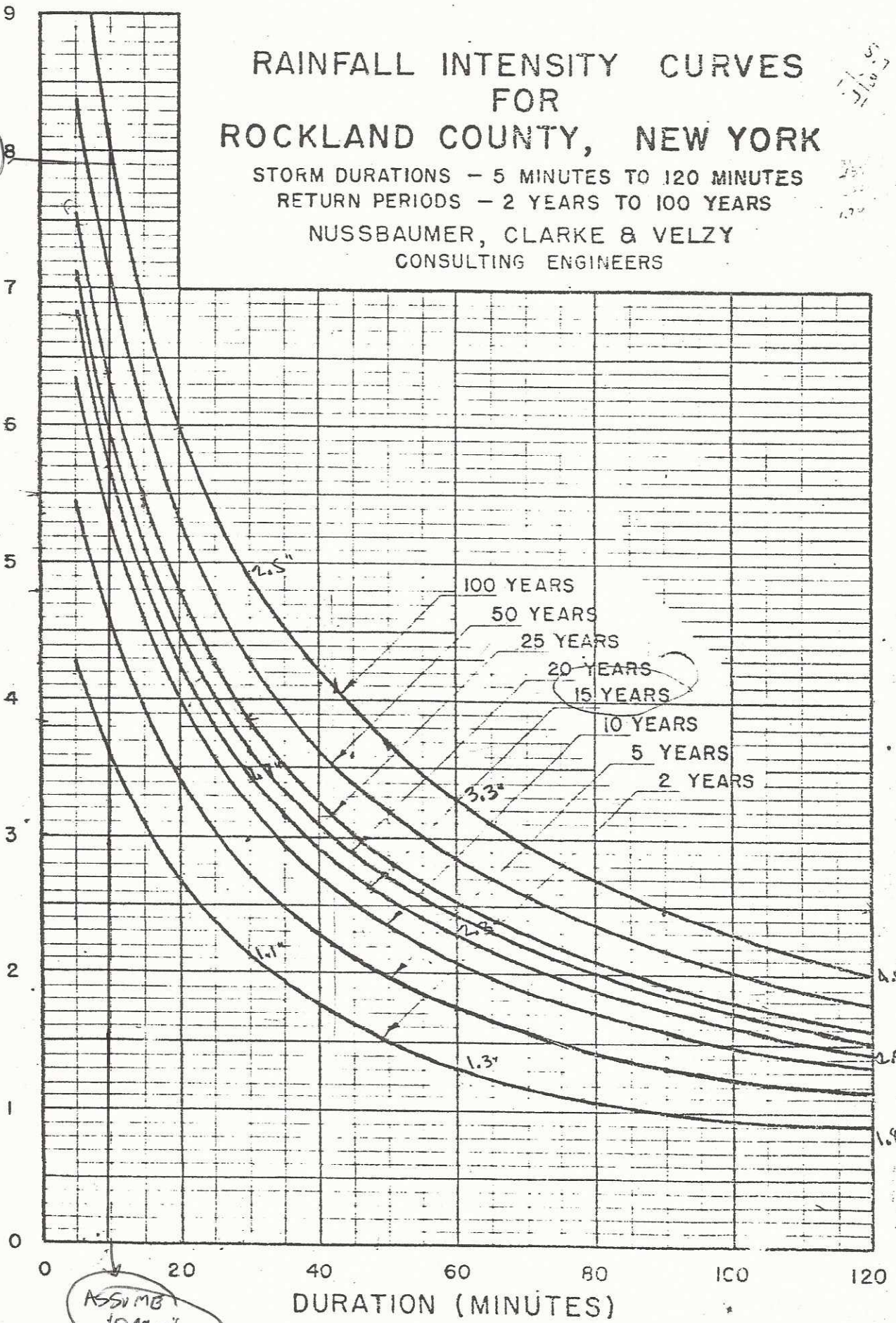

SLOPE FACTOR NOMOGRAM AND RUNOFF COEFFICIENTS

NUSSBAUMER, CLARKE & VELZY
CONSULTING ENGINEERS

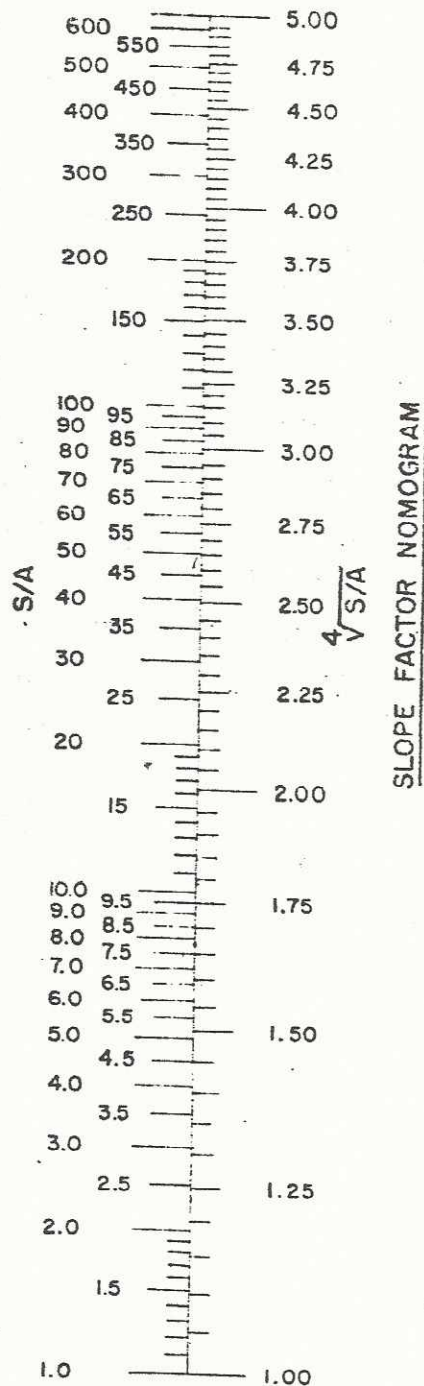

COEFFICIENTS OF IMPERVIOUSNESS

Roofs	0.90
Pavements and Sidewalks	
Concrete	0.90
Bituminous Macadam	0.85
Earth	0.50
Gravel	0.30
Gardens and Lawns	0.20 ✓
Farm Land and Meadow	0.15
Flat Wooded Areas	0.10

RECOMMENDED MINIMUM RUNOFF COEFFICIENTS FOR VARIOUS CATEGORIES OF LAND USE

Land Use	Runoff Coefficient "C"
Residential	
Lot Sizes	
80,000 Sq.Ft. and over	0.15
15,000 " " " "	0.30
7,000 " " " "	0.40
Industrial	0.60
Commercial	0.75

↓
 16,000 SF
 LOTS - USE
 TO BE
 CONSERVATIVE

Pipe flowing full:

$$Q=1.486/n*((\pi*D^2)/4)^{2/3}*S^{1/2}$$

n= 0.011
D= 3 FT
S= 0.053

Q= 124.8221 CFS

Drainage Area Flow Calculation:(Existing 100 Year Flow)

$$Q=CIA$$

C= 0.4
I= 7.8 In/Hr
A= 13.5 Acres
Q= 42.12 CFS

RIP RAP
CALC.

Figure 3.16
Outlet Protection Design—Minimum Tailwater Condition Chart
 (Design of Outlet Protection from a Round Pipe Flowing Full,
 Minimum Tailwater Condition: $T_w < 0.5D_o$) (USDA - NRCS)

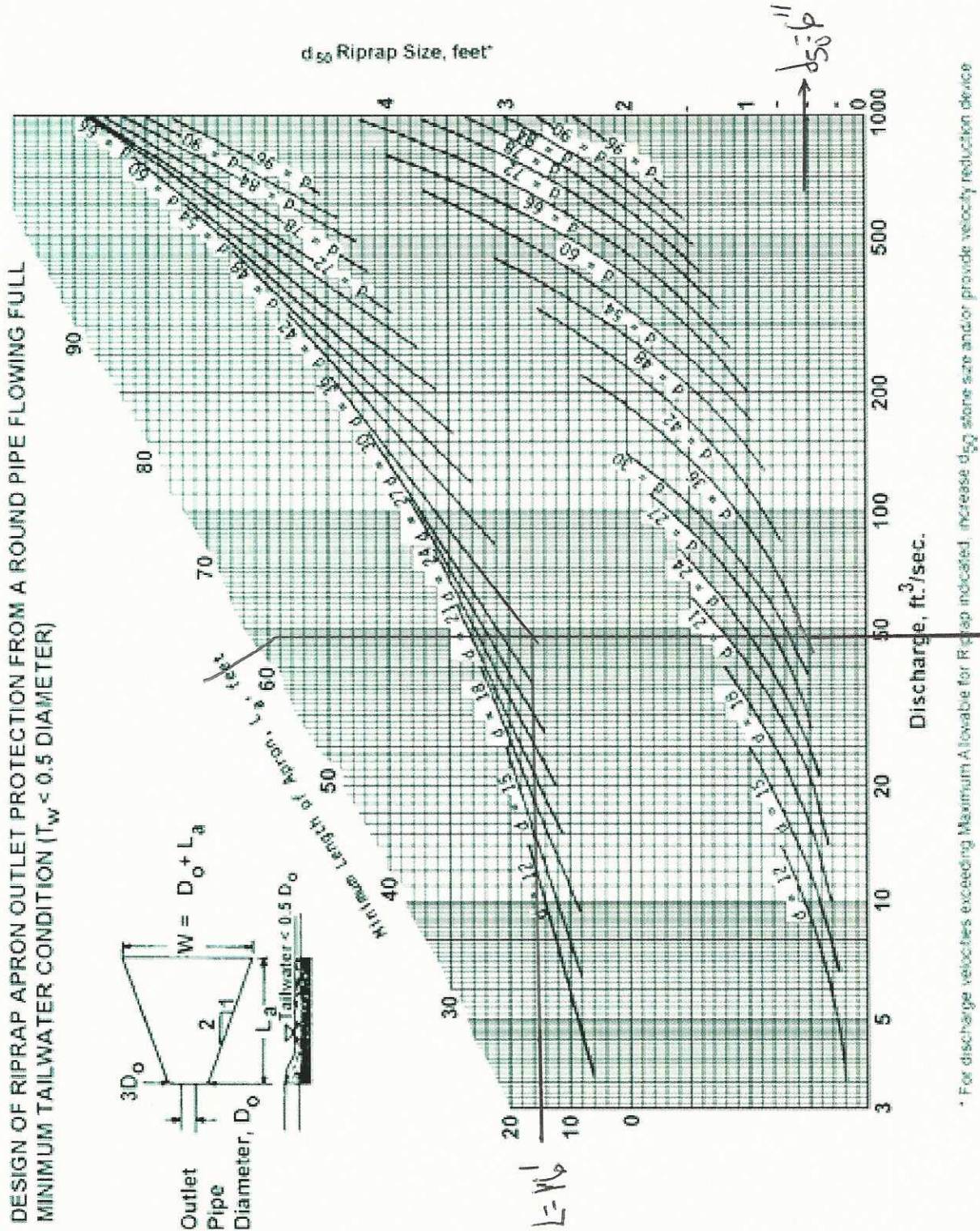

Montalbano, Condon & Frank, P.C.

Richard H. Sarajian*
Alan G. Rosenblatt
Brian J. Quinn
John E. Finnegan
David Warren*
Charlotte G. Swift*
Lino J. Sciarretta*

ATTORNEYS AND COUNSELORS AT LAW

67 North Main Street • New City, New York 10956-8070

PHONE (845) 634-7010 FAX (845) 634-8993

*Kurt E. Johnson
Martin Butcher
**Andrew Ross
Rudolph O.Zodda, III

OF COUNSEL:
Anthony Montalbano
Thomas A. Condon
William Frank

*ADMITTED IN NY & NJ
**ADMITTED IN NY & MA

August 30, 2018

Via Federal Express

Hon. Rosanna Sfraga
Town Clerk
Town of Orangetown
26 W. Orangeburg Road
Orangeburg, NY 10962

RE: Town Code Chapter 41 – Watercourse Diversion Permit
27 Sunrise Lane, Pearl River, NY (the “Property”)
Kreiger Estate – Section 69.18, Block 3, Lot 43.2

Dear Town Clerk Sfraga:

We represent Steven Griffin in connection with the above-referenced matter. Enclosed are eight (8) sets of plans, pipe calculations, and check in the amount of \$100 payable to the Town of Orangetown for a watercourse diversion permit.

The Property, which is pending before the Planning Board, is for the construction of a single-family residence. In connection with the site plan approval, Griffin has been asked by the Town Highway Department and Department of Environmental Management and Engineering to relocate an existing 24-inch storm water pipe away from the proposed residence. To that end, Griffin proposes to install a new 36' drainage pipe running approximately 92-feet into a RIPRAP outlet protection. This proposed pipe will be more than 15 feet away from the proposed residence. This new drainage system will eliminate an open ditch condition presently on the site.

We respectfully request that this item be placed on the Town Board agenda for consideration. Please let us know the date of that Town Board meeting. We thank you for your consideration and attention to this mater.

August 30, 2018
Page 2

Very truly yours,

MONTALBANO, CONDON & FRANK, P.C.



LINO J. SCIARRETTA

LS/br

Enclosures

cc: James Dean, Superintendent of Highways (w/ enclosures)
Joseph Moran, Commissioner DEME (w/ enclosures)
Robert Magrino, Town Attorney (w/o enclosures)

MONTALBANO CONDON & FRANK PC

4424

714.0034 Town of Orangetown
08/30/18 9595.1 Griff - Application Fee

100.00

100.00

08/30/18 4424 Gross: 100.00 Ded: 0.00 Net: 100.00

4424

MONTALBANO CONDON & FRANK PC
OPERATING ACCOUNT
67 N MAIN ST # 3
NEW CITY, NY 109563700

M&T Bank

10-4/220

DATE
08/30/18

AMOUNT
****\$100.00

*** ONE HUNDRED & 00/100 DOLLARS

PAY

TO THE ORDER OF:
Town of Orangetown
26 Orangeburg Road
Orangeburg NY 10962



John E. Finnegan
AUTHORIZED SIGNATURE

Security features. Details on back.

⑈004424⑈

⑆022000046⑆

9861067784⑈

PROPOSAL

Traffic Signal Design & Construction Inspection Services For Project to Improve 10 Traffic Signals at Various Locations Orangetown, New York.

➤ **PROPOSAL TO BE SUPPLIED ON THIS PAGE ONLY AND IS NOT TO BE REVISED**

1. Design Phase, 10 Traffic Signals at Various Locations
RFP Items # 1 thru #8
(Fee Schedule to Also Be Attached)

\$183,830.00

One hundred eighty-three thousand eight hundred thirty dollars
Written Dollar Amount for Design Phase

2. Construction Inspection Services and Related Activities RFP Item #9
(Fee Schedule for Hourly Rates and Daily Rates to Be Attached)

John T. Collins - Exec. Principal
NAME & TITLE

8/31/18
DATE

[Signature]
SIGNATURE

Mazen Consulting
COMPANY NAME

400 Columbus Ave - Valhalla NY 10595
ADDRESS

914 347-7500
CONTACT TELEPHONE NUMBER

RECEIVED

SEP 12 2018

TOWN OF ORANGETOWN
HIGHWAY DEPARTMENT

TOWN OF ORANGETOWN
SPECIAL USE PERMIT FOR USE OF TOWN PROPERTY

PERMIT # 18-57-52

RECEIVED
SEP 19 2018
Orangetown Police Department

EVENT NAME: South Orangetown Day

APPLICANT NAME: Marisa Marrone

ADDRESS: 29 Fairview lane Orangetown, NY 10902

PHONE #: - CELL # (914) 629-7508 FAX # -

CHECK ONE: PARADE - RACE/RUN/WALK - OTHER Event

The above event will be held on Oct. 13th from 11 am to 5 pm RAIN DATE: -

Location of event: The Greens at the Manse Barn Tappan, NY

Sponsored by: S.O.D. Committee Telephone #: (914) 629-7508

Address: -

Estimated # of persons participating in event: 300 vehicles 150

Person (s) responsible for restoring property to its original condition: Name-Address-Phone #:

Marisa Marrone 29 Fairview lane Orangetown, NY 10902

Signature of Applicant: Marisa Marrone Date: 9/12/2018

GENERAL INFORMATION REQUIRED: (HIGHWAY/PARKS)

Letter of Request to Town Board requesting aid for event - Received On: 9.12.18

Certificate of Insurance - Received On: 9.12.18

FOR HIGHWAY DEPARTMENT USE ONLY:

Road Closure Permit: Y Received On: 9.17.18

Rockland County Highway Dept. Permit: Y Received On: -

NYS DOT Permit: Y Received On: -

Route/Map/Parking Plan: Y Received On: -

RFS #: 42593 BARRICADES: Y CONES: Y TRASH BARRELS: Y OTHER: bins/bags Message Board

APPROVED: [Signature] DATE: 9.17.18
Superintendent of Highways

FOR PARKS & RECREATION DEPARTMENT USE ONLY:

Showmobile: Y Application Required: - Fee Paid - Amount/Check # -

Port-o-Sans: Y (2) one handicapped Other: -

APPROVED: [Signature] DATE: 9/18/18
Superintendent of Parks & Recreation

FOR POLICE DEPARTMENT USE ONLY:

APPROVED: [Signature] DATE: 9/19/18
Chief of Police

** (Please return to the Highway AND/OR Parks Department to be placed on the Town Board Agenda) **

Workshop Agenda Date: - Approved On: - TBR #: -

RECEIVED

SEP 20 2018

TOWN OF ORANGETOWN
HIGHWAY DEPARTMENT

RECEIVED

sent to RCAD - 9.17.18

SEP 17 2018

JAMES J. DEAN
Superintendent of Highways
Roadmaster II

TOWN OF ORANGETOWN
HIGHWAY DEPARTMENT

HIGHWAY DEPARTMENT
TOWN OF ORANGETOWN
119 Route 303 • Orangeburg, NY 10962
(845) 359-6500 • Fax (845) 359-6062
E-mail - highwaydept@oragetown.com



Orangeburg Representative
R.C. Soil & Water Conservation Dist.-Chairman
Member:
American Public Works Association NY Metro Chapter
NYS Association of Town Superintendents of Highways
Hwy. Superintendents' Association of Rockland County

ROAD CLOSING PERMIT APPLICATION
Section 139 Highway Law

NAME Marisa Marrone DATE 9/14/2018
COMPANY South Orangeburg Day
ADDRESS 29 Fairview Lane Orangeburg NY 10962
TELEPHONE (914) 629-7508
(INCLUDE 24 HOUR EMERGENCY NUMBERS)

ABOVE MENTIONED PARTY REQUESTS PERMISSION TO CLOSE:

Greenbush Road / Main Street (one way road)
(Address number and name of road)

Old Tappan Road, Kings Hwy.
(Intersecting streets and/or description of exact location)

REASON FOR CLOSING South Orangeburg Day Event - location of stage

DATE OF CLOSING 10/13/2018 RAIN DATE N/A

TIME ROAD WILL BE CLOSED 10 AM

WILL ROAD BE OPEN TO LOCAL TRAFFIC? NO

WILL ROAD BE OPEN TO EMERGENCY VEHICLES? NO

PLEASE PROVIDE A DETAILED MAP AND DESCRIPTION OF DETOUR IF TRAVEL WILL BE RESTRICTED.

PRELIMINARY APPROVAL [Signature] DATE 9.17.18

JAMES J. DEAN
SUPERINTENDENT OF HIGHWAYS

This permit application will be forwarded to the Rockland County Superintendent of Highways, County of Rockland, 23 New Hempstead Road, New City, NY, 10956. You will receive written confirmation from that office.

8-13-02bjd

HAMLETS: PEARL RIVER • BLAUVELT • ORANGETOWN • TAPPAN • SPARKILL • PALISADES • UPPER GRANDVIEW



CLEAN STREETS-CLEAN STREAMS

Helen Wilson

SEP 12 2018

From: Marisa Marrone <marisamarrone@gmail.com>
Sent: Wednesday, September 12, 2018 2:06 PM
To: Katherine Fairclough; Stephen Munno; Helen Wilson
Subject: Fwd: FW: Request for Attachment: NORTHERN COMFORT HOSPITALITY GROUP-01SBMAT3842
Attachments: BISF-20351101_01SBMAT3842-962017_09052018 100322.pdf; BISF-20351101_01SBMAT3842-09062018_09052018 100537.pdf; image1.jpg; SOD Flyer 18pdf.pdf; SODvaso2018 pdf.pdf; 2018 Showmobile Application.pdf

TOWN OF ORANGETOWN
HIGHWAY DEPARTMENT

To Town Board,

Please see the attached proof of insurance for South Orangetown Day taking place on October 13th at the Tappan Reformed Church on the Manse Lawn from 11-5pm.

This email is to request both town and highway department to attend the event and distribute leaf bags, recycling bins as well as other recycling information. *HW*

The event would also like to request the road closure of the one way on Greenbush Rd. and Main Street so the *Perks* showmobile has a spot. It seemed to work perfectly as measurements were taken last year.

We also like to request several barricades, cones to close off parking sections, six trash barrels, *Perks* two ports sans, one being for handicapped.

We would greatly appreciate promoting the event like in the past with the Electric sign in front of Town Hall.

Please let me know what else you need to expedite all the requests.

Thank you so much for your support,

Marisa Marrone

S.O.D Committee

(914)629-7508

----- Forwarded message -----

From: **Marisa Marrone** <marisamarrone@gmail.com>

Date: Wed, Sep 12, 2018 at 10:10 AM

Subject: Fwd: FW: Request for Attachment: NORTHERN COMFORT HOSPITALITY GROUP-01SBMAT3842

To: Mark Albert <malbert@orangetown.com>

Here is the Insurance certificate for South Orangetown Day.

Marisa

----- Forwarded message -----

From: **Joe Agnello** <joe@nococatering.com>

Date: Fri, Sep 7, 2018 at 4:55 PM

Subject: FW: Request for Attachment: NORTHERN COMFORT HOSPITALITY GROUP- 01SBMAT3842

To: <marisamarrone@gmail.com>

Joe Agnello

RECEIVED

NoCo Catering

SEP 12 2018

845-445-7332

TOWN OF ORANGETOWN
HIGHWAY DEPARTMENT

www.nococatering.com

Download Our Mobile App for Discounts Specials and Event Schedules:

From: agency.service@thehartford.com [mailto:agency.service@thehartford.com]

Sent: Wednesday, September 05, 2018 10:06 AM

To: JOE@NOCOCATERING.COM; MALBERT@ORANGETOWN.COM

Subject: Request for Attachment: NORTHERN COMFORT HOSPITALITY GROUP- 01SBMAT3842



September 5, 2018

Account Name : NORTHERN COMFORT HOSPITALITY GROUP

Comments :

Per Your Request.

Please do not reply back to this email. You may contact us directly at the phone number or e-mail address noted below.

Thank you.

Your Hartford Services Team,

(877)853-2582 (Agency Callers)

(866)467-8730 (Policyholders)

Agency.Services@TheHartford.com (All Customers)



CERTIFICATE OF LIABILITY INSURANCE

DATE (MM/DD/YYYY)
9/5/2018

THIS CERTIFICATE IS ISSUED AS A MATTER OF INFORMATION ONLY AND CONFERS NO RIGHTS UPON THE CERTIFICATE HOLDER. THIS CERTIFICATE DOES NOT AFFIRMATIVELY OR NEGATIVELY AMEND, EXTEND OR ALTER THE COVERAGE AFFORDED BY THE POLICIES BELOW. THIS CERTIFICATE OF INSURANCE DOES NOT CONSTITUTE A CONTRACT BETWEEN THE ISSUING INSURER(S), AUTHORIZED REPRESENTATIVE OR PRODUCER, AND THE CERTIFICATE HOLDER.

IMPORTANT: If the certificate holder is an ADDITIONAL INSURED, the policy(ies) must have ADDITIONAL INSURED provisions or be endorsed. If SUBROGATION IS WAIVED, subject to the terms and conditions of the policy, certain policies may require an endorsement. A statement on this certificate does not confer rights to the certificate holder in lieu of such endorsement(s).

PRODUCER		CONTACT NAME:	
NORTHEAST AGENCIES INC/PHS		PHONE (A/C, No, Ext): (866) 467-8730	FAX (A/C, No): (888) 443-6112
210619 P:(866) 467-8730 F:(888) 443-6112		E-MAIL ADDRESS:	
301 WOODS PARK DRIVE		INSURER(S) AFFORDING COVERAGE	
CLINTON NY 13323		INSURER A: Sentinel Ins Co LTD	
		NAIC# 11000	
INSURED		INSURER B:	
NORTHERN COMFORT HOSPITALITY GROUP		INSURER C:	
22 GREENBUSH RD		INSURER D:	
TAPPAN NY 10983		INSURER E:	
		INSURER F:	

RECEIVED

SEP 12 2018

TOWN OF ORANGETOWN
HIGHWAY DEPARTMENT

COVERAGES CERTIFICATE NUMBER: REVISION NUMBER:

THIS IS TO CERTIFY THAT THE POLICIES OF INSURANCE LISTED BELOW HAVE BEEN ISSUED TO THE INSURED NAMED ABOVE FOR THE POLICY PERIOD INDICATED. NOTWITHSTANDING ANY REQUIREMENT, TERM OR CONDITION OF ANY CONTRACT OR OTHER DOCUMENT WITH RESPECT TO WHICH THIS CERTIFICATE MAY BE ISSUED OR MAY PERTAIN, THE INSURANCE AFFORDED BY THE POLICIES DESCRIBED HEREIN IS SUBJECT TO ALL THE TERMS, EXCLUSIONS AND CONDITIONS OF SUCH POLICIES. LIMITS SHOWN MAY HAVE BEEN REDUCED BY PAID CLAIMS.

INSR LTR	TYPE OF INSURANCE	ADDL INSR	SUBR WVD	POLICY NUMBER	POLICY EFF (MM/DD/YYYY)	POLICY EXP (MM/DD/YYYY)	LIMITS	
A	COMMERCIAL GENERAL LIABILITY			01 SBM AT3842	09/06/2018	09/06/2019	EACH OCCURRENCE	\$1,000,000
	<input type="checkbox"/> CLAIMS-MADE <input checked="" type="checkbox"/> OCCUR						DAMAGE TO RENTED PREMISES (Ea occurrence)	\$1,000,000
	<input checked="" type="checkbox"/> General Liab	X					MED EXP (Any one person)	\$10,000
	GEN'L AGGREGATE LIMIT APPLIES PER: <input type="checkbox"/> POLICY <input type="checkbox"/> PRO-JECT <input checked="" type="checkbox"/> LOC OTHER:						PERSONAL & ADV INJURY	\$1,000,000
A	AUTOMOBILE LIABILITY			01 SBM AT3842	09/06/2018	09/06/2019	COMBINED SINGLE LIMIT (Ea accident)	\$1,000,000
	ANY AUTO OWNED AUTOS ONLY						BODILY INJURY (Per person)	\$
	<input checked="" type="checkbox"/> HIRED AUTOS ONLY <input checked="" type="checkbox"/> SCHEDULED AUTOS NON-OWNED AUTOS ONLY						BODILY INJURY (Per accident)	\$
							PROPERTY DAMAGE (Per accident)	\$
	UMBRELLA LIAB						EACH OCCURRENCE	\$
	EXCESS LIAB						AGGREGATE	\$
	DED	RETENTION \$						\$
	WORKERS COMPENSATION AND EMPLOYERS' LIABILITY						PER STATUTE	OTH-ER
	ANY PROPRIETOR/PARTNER/EXECUTIVE OFFICER/MEMBER EXCLUDED? (Mandatory in NH)		N/A				E.L. EACH ACCIDENT	\$
	If yes, describe under DESCRIPTION OF OPERATIONS below						E.L. DISEASE - EA EMPLOYEE	\$
							E.L. DISEASE - POLICY LIMIT	\$

DESCRIPTION OF OPERATIONS / LOCATIONS / VEHICLES (ACORD 101, Additional Remarks Schedule, may be attached if more space is required)

Those usual to the Insured's Operations. Certificate holder is an additional insured per the Business Liability Coverage Form SS 00 08 attached to this policy.

CERTIFICATE HOLDER

TOWN OF ORANGETOWN
26 W ORANGEBURG RD
ORANGEBURG, NY 10962

CANCELLATION

SHOULD ANY OF THE ABOVE DESCRIBED POLICIES BE CANCELLED BEFORE THE EXPIRATION DATE THEREOF, NOTICE WILL BE DELIVERED IN ACCORDANCE WITH THE POLICY PROVISIONS.

AUTHORIZED REPRESENTATIVE

Susan L. Castaneda

NORTHEAST AGENCIES INC/PHS
301 WOODS PARK DRIVE
CLINTON NY 13323

TOWN OF ORANGETOWN
26 W ORANGEBURG RD
ORANGEBURG NY 10962



TOWN OF ORANGETOWN PARKS & RECREATION
81 HUNT ROAD, ORANGEBURG, NY 10962
(845) 359-6503



2018 Application for Showmobile Use

Event/Festival Name: South Orangetown Day

Organization Name: South Orangetown Day Committee

Applicant's Name: Marisa Marrone Phone (w): (914) 629-7508

Address: 39 Fairview Ln City: Orangetown Zip: 10902

Cell Phone: (914) 629-7508 E-Mail: Marisamarrone@gmail.com

Day: Saturday Date: Oct. 13, 2018 Time of Set-up: 9 AM Time of Take-down: 6 PM

Requested Location (park, street, location on premises, etc., be specific, attach map if needed):
The Manse Barn at the Tappan Reformed Church
32 Old Tappan Road Tappan, NY 10983

Showmobile stage measures 28 feet long x 14 feet 7 inches deep x 25 feet high when open. One set of stairs is available with hand railings. (Please note that this measurement does not include the trailer hitch or the tow vehicle. See space requirements below.) *The Showmobile does not have a sound system and comes with fluorescent lighting only.*

Stair Arrangement: (1 set of stairs) Left side of stage Right side of stage Front of stage

The lights require a 110 volt, 20 amp circuit to plug into within 150 feet of the right front side of the Showmobile. The stage does not come with a generator. Additional electrical equipment must be plugged into a separate circuit. Sign or banners may only be hung with permission.

Please describe in detail what the stage will be used for and how you intend to set it up: (Note: The Town seal is not to be covered and no nails, staples or tacks may be used to attach any items to the Showmobile)

local bands to play for the day

Showmobile space requirements:

- The showmobile must be parked in a relatively level space.
- The area must be free of obstructions such as overhanging tree limbs, electrical wires, etc.
- The total area needed for the showmobile is a space 50 feet in length, 15 feet in width and 25 feet in height.
- The tow vehicle must remain with the showmobile for the duration of the event.
- In the event of winds or wind gusts in excess of 30 MPH, the stage canopy must be closed.

Additional Requirements:

- Certificate of insurance required at time of reservation naming the Town of Orangetown as additionally insured.
- Any changes to the event must be made 24 hours in advance by contacting Mark Albert at malbert@orangetown.com

I have read, understand and agree to all conditions listed on above:

Applicant's Signature: Marisa Marrone Date: 7/28/2018

Department Approval: Mat W Date: 9/10/18



CERTIFICATE OF LIABILITY INSURANCE

DATE (MM/DD/YYYY)
9/5/2018

THIS CERTIFICATE IS ISSUED AS A MATTER OF INFORMATION ONLY AND CONFERS NO RIGHTS UPON THE CERTIFICATE HOLDER. THIS CERTIFICATE DOES NOT AFFIRMATIVELY OR NEGATIVELY AMEND, EXTEND OR ALTER THE COVERAGE AFFORDED BY THE POLICIES BELOW. THIS CERTIFICATE OF INSURANCE DOES NOT CONSTITUTE A CONTRACT BETWEEN THE ISSUING INSURER(S), AUTHORIZED REPRESENTATIVE OR PRODUCER, AND THE CERTIFICATE HOLDER.

IMPORTANT: If the certificate holder is an ADDITIONAL INSURED, the policy(ies) must have ADDITIONAL INSURED provisions or be endorsed. If SUBROGATION IS WAIVED, subject to the terms and conditions of the policy, certain policies may require an endorsement. A statement on this certificate does not confer rights to the certificate holder in lieu of such endorsement(s).

PRODUCER	CONTACT NAME:
NORTHEAST AGENCIES INC/PHS 210619 P:(866) 467-8730 F:(888) 443-6112 301 WOODS PARK DRIVE CLINTON NY 13323	PHONE (A/C, No, Ext): (866) 467-8730 FAX (A/C, No): (888) 443-6112
	E-MAIL ADDRESS:
	INSURER(S) AFFORDING COVERAGE NAIC#
	INSURER A: Sentinel Ins Co LTD 11000
INSURED	INSURER B:
NORTHERN COMFORT HOSPITALITY GROUP 22 GREENBUSH RD TAPPAN NY 10983	INSURER C:
	INSURER D:
	INSURER E:
	INSURER F:

COVERAGES **CERTIFICATE NUMBER:** **REVISION NUMBER:**

THIS IS TO CERTIFY THAT THE POLICIES OF INSURANCE LISTED BELOW HAVE BEEN ISSUED TO THE INSURED NAMED ABOVE FOR THE POLICY PERIOD INDICATED. NOTWITHSTANDING ANY REQUIREMENT, TERM OR CONDITION OF ANY CONTRACT OR OTHER DOCUMENT WITH RESPECT TO WHICH THIS CERTIFICATE MAY BE ISSUED OR MAY PERTAIN, THE INSURANCE AFFORDED BY THE POLICIES DESCRIBED HEREIN IS SUBJECT TO ALL THE TERMS, EXCLUSIONS AND CONDITIONS OF SUCH POLICIES. LIMITS SHOWN MAY HAVE BEEN REDUCED BY PAID CLAIMS.

INSR LTR	TYPE OF INSURANCE	ADDL INSR	SUBR WVD	POLICY NUMBER	POLICY EFF (MM/DD/YYYY)	POLICY EXP (MM/DD/YYYY)	LIMITS
A	COMMERCIAL GENERAL LIABILITY			01 SBM AT3842	09/06/2017	09/06/2018	EACH OCCURRENCE \$1,000,000
	<input type="checkbox"/> CLAIMS-MADE <input checked="" type="checkbox"/> OCCUR						DAMAGE TO RENTED PREMISES (Ea occurrence) \$1,000,000
	<input checked="" type="checkbox"/> General Liab	X					MED EXP (Any one person) \$10,000
	GEN'L AGGREGATE LIMIT APPLIES PER:						PERSONAL & ADV INJURY \$1,000,000
	<input type="checkbox"/> POLICY <input type="checkbox"/> PRO-JECT <input checked="" type="checkbox"/> LOC						GENERAL AGGREGATE \$2,000,000
	OTHER:						PRODUCTS - COMP/OP AGG \$2,000,000
							\$
A	AUTOMOBILE LIABILITY			01 SBM AT3842	09/06/2017	09/06/2018	COMBINED SINGLE LIMIT (Ea accident) \$1,000,000
	<input type="checkbox"/> ANY AUTO OWNED AUTOS ONLY <input type="checkbox"/> HIRED AUTOS ONLY						BODILY INJURY (Per person) \$
	<input checked="" type="checkbox"/> SCHEDULED AUTOS <input checked="" type="checkbox"/> NON-OWNED AUTOS ONLY	X					BODILY INJURY (Per accident) \$
							PROPERTY DAMAGE (Per accident) \$
							\$
	UMBRELLA LIAB						EACH OCCURRENCE \$
	EXCESS LIAB						AGGREGATE \$
							\$
							\$
	WORKERS COMPENSATION AND EMPLOYERS' LIABILITY						<input type="checkbox"/> PER STATUTE <input type="checkbox"/> OTHER
	ANY PROPRIETOR/PARTNER/EXECUTIVE OFFICER/MEMBER EXCLUDED? (Mandatory in NH)		N/A				E.L. EACH ACCIDENT \$
	If yes, describe under DESCRIPTION OF OPERATIONS below						E.L. DISEASE - EA EMPLOYEE \$
							E.L. DISEASE - POLICY LIMIT \$

DESCRIPTION OF OPERATIONS / LOCATIONS / VEHICLES (ACORD 101, Additional Remarks Schedule, may be attached if more space is required)

Those usual to the Insured's Operations. Certificate holder is an additional insured per the Business Liability Coverage Form SS 00 08 attached to this policy.

CERTIFICATE HOLDER **CANCELLATION**

TOWN OF ORANGETOWN 26 W ORANGETOWN RD ORANGETOWN, NY 10962	SHOULD ANY OF THE ABOVE DESCRIBED POLICIES BE CANCELLED BEFORE THE EXPIRATION DATE THEREOF, NOTICE WILL BE DELIVERED IN ACCORDANCE WITH THE POLICY PROVISIONS. AUTHORIZED REPRESENTATIVE <i>Susan S. Castaneda</i>
--	---

NORTHEAST AGENCIES INC/PHS
301 WOODS PARK DRIVE
CLINTON NY 13323

TOWN OF ORANGETOWN
26 W ORANGEBURG RD
ORANGEBURG NY 10962



CERTIFICATE OF LIABILITY INSURANCE

DATE (MM/DD/YYYY)
9/5/2018

THIS CERTIFICATE IS ISSUED AS A MATTER OF INFORMATION ONLY AND CONFERS NO RIGHTS UPON THE CERTIFICATE HOLDER. THIS CERTIFICATE DOES NOT AFFIRMATIVELY OR NEGATIVELY AMEND, EXTEND OR ALTER THE COVERAGE AFFORDED BY THE POLICIES BELOW. THIS CERTIFICATE OF INSURANCE DOES NOT CONSTITUTE A CONTRACT BETWEEN THE ISSUING INSURER(S), AUTHORIZED REPRESENTATIVE OR PRODUCER, AND THE CERTIFICATE HOLDER.

IMPORTANT: If the certificate holder is an ADDITIONAL INSURED, the policy(ies) must have ADDITIONAL INSURED provisions or be endorsed. If SUBROGATION IS WAIVED, subject to the terms and conditions of the policy, certain policies may require an endorsement. A statement on this certificate does not confer rights to the certificate holder in lieu of such endorsement(s).

PRODUCER NORTHEAST AGENCIES INC/PHS 210619 P:(866) 467-8730 F:(888) 443-6112 301 WOODS PARK DRIVE CLINTON NY 13323	CONTACT NAME: PHONE (A/C, No, Ext): (866) 467-8730	FAX (A/C, No): (888) 443-6112
	E-MAIL ADDRESS:	
INSURER(S) AFFORDING COVERAGE		NAIC#
INSURER A: Sentinel Ins Co LTD		11000
INSURED NORTHERN COMFORT HOSPITALITY GROUP 22 GREENBUSH RD TAPPAN NY 10983		
INSURER B :		
INSURER C :		
INSURER D :		
INSURER E :		
INSURER F :		

COVERAGES **CERTIFICATE NUMBER:** **REVISION NUMBER:**

THIS IS TO CERTIFY THAT THE POLICIES OF INSURANCE LISTED BELOW HAVE BEEN ISSUED TO THE INSURED NAMED ABOVE FOR THE POLICY PERIOD INDICATED. NOTWITHSTANDING ANY REQUIREMENT, TERM OR CONDITION OF ANY CONTRACT OR OTHER DOCUMENT WITH RESPECT TO WHICH THIS CERTIFICATE MAY BE ISSUED OR MAY PERTAIN, THE INSURANCE AFFORDED BY THE POLICIES DESCRIBED HEREIN IS SUBJECT TO ALL THE TERMS, EXCLUSIONS AND CONDITIONS OF SUCH POLICIES. LIMITS SHOWN MAY HAVE BEEN REDUCED BY PAID CLAIMS.

INSR LTR	TYPE OF INSURANCE	ADDL INSR	SUBR WVD	POLICY NUMBER	POLICY EFF (MM/DD/YYYY)	POLICY EXP (MM/DD/YYYY)	LIMITS	
A	COMMERCIAL GENERAL LIABILITY <input type="checkbox"/> CLAIMS-MADE <input checked="" type="checkbox"/> OCCUR <input checked="" type="checkbox"/> General Liab GEN'L AGGREGATE LIMIT APPLIES PER: <input type="checkbox"/> POLICY <input type="checkbox"/> PRO-JECT <input checked="" type="checkbox"/> LOC OTHER:	X		01 SBM AT3842	09/06/2017	09/06/2018	EACH OCCURRENCE	\$1,000,000
							DAMAGE TO RENTED PREMISES (Ea occurrence)	\$1,000,000
							MED EXP (Any one person)	\$10,000
							PERSONAL & ADV INJURY	\$1,000,000
							GENERAL AGGREGATE	\$2,000,000
							PRODUCTS - COMP/OP AGG	\$2,000,000
A	AUTOMOBILE LIABILITY <input type="checkbox"/> ANY AUTO OWNED <input type="checkbox"/> AUTOS ONLY <input checked="" type="checkbox"/> HIRED AUTOS ONLY <input type="checkbox"/> SCHEDULED AUTOS <input checked="" type="checkbox"/> NON-OWNED AUTOS ONLY			01 SBM AT3842	09/06/2017	09/06/2018	COMBINED SINGLE LIMIT (Ea accident)	\$1,000,000
							BODILY INJURY (Per person)	\$
							BODILY INJURY (Per accident)	\$
							PROPERTY DAMAGE (Per accident)	\$
								\$
	UMBRELLA LIAB <input type="checkbox"/> OCCUR EXCESS LIAB <input type="checkbox"/> CLAIMS-MADE DED RETENTION \$						EACH OCCURRENCE	\$
							AGGREGATE	\$
								\$
	WORKERS COMPENSATION AND EMPLOYERS' LIABILITY ANY PROPRIETOR/PARTNER/EXECUTIVE OFFICER/MEMBER EXCLUDED? (Mandatory in NH) <input type="checkbox"/> If yes, describe under DESCRIPTION OF OPERATIONS below	N/A					PER STATUTE	OTH-ER
							E.L. EACH ACCIDENT	\$
							E.L. DISEASE - EA EMPLOYEE	\$
							E.L. DISEASE - POLICY LIMIT	\$

DESCRIPTION OF OPERATIONS / LOCATIONS / VEHICLES (ACORD 101, Additional Remarks Schedule, may be attached if more space is required)

Those usual to the Insured's Operations. Certificate holder is an additional insured per the Business Liability Coverage Form SS 00 08 attached to this policy.

CERTIFICATE HOLDER **CANCELLATION**

TOWN OF ORANGETOWN 26 W ORANGEBURG RD ORANGEBURG, NY 10962	SHOULD ANY OF THE ABOVE DESCRIBED POLICIES BE CANCELLED BEFORE THE EXPIRATION DATE THEREOF, NOTICE WILL BE DELIVERED IN ACCORDANCE WITH THE POLICY PROVISIONS. AUTHORIZED REPRESENTATIVE <i>Susan S. Castaneda</i>
--	--

RECEIVED

TOWN OF ORANGETOWN
SPECIAL USE PERMIT FOR USE OF TOWN PROPERTY/ITEMS

PERMIT # 18-52-51

SEP 12 2018

EVENT NAME: PRMS PTA Color Run
TOWN OF ORANGETOWN
HIGHWAY DEPARTMENT APPLICANT NAME: Pearl River Middle School P.T.A.

ADDRESS: 520 Gilbert Ave, Pearl River NY

PHONE #: _____ CELL # _____ FAX # _____

CHECK ONE: PARADE _____ RACE/RUN/WALK OTHER _____

The above event will be held on Sept. 23 from 9am to 2pm RAIN DATE: _____

Location of event: Pearl River Middle School

Sponsored by: PTA PRMS Telephone #: 201 978 0320

Address: 520 Gilbert Ave Pearl River NY

Estimated # of persons participating in event: 250 vehicles 0

Person (s) responsible for restoring property to its original condition: Name-Address-Phone #:

Suzanne Finnegan (201) 978-0320

Signature of Applicant: Suzanne Finnegan Date: 9/12/18

GENERAL INFORMATION REQUIRED: (HIGHWAY/PARKS/POLICE)

Letter of Request to Town Board requesting aid for event - Received On: 9/12-18

Certificate of Insurance - Received On: Y

FOR HIGHWAY DEPARTMENT USE ONLY:

Road Closure Permit: Y / Received On: _____

Rockland County Highway Dept. Permit: Y / Received On: _____

NYSDOT Permit: Y / Received On: _____

Route/Map/Parking Plan: Y / Received On: 9-13-18

RFS #: 42592 BARRICADES: Y / CONES: Y / TRASH BARRELS: Y / OTHER: _____

APPROVED: [Signature] DATE: 9.14.18
Superintendent of Highways

FOR PARKS & RECREATION DEPARTMENT USE ONLY:

Show Mobile: Y / Application Required: X Fee Paid - Amount/Check # _____ RECEIVED

Port-o-Sans: Y / Other: _____

APPROVED: [Signature] DATE: 9/12/18
Superintendent of Parks & Recreation

SEP 18 2018

TOWN OF ORANGETOWN
HIGHWAY DEPARTMENT

FOR POLICE DEPARTMENT USE ONLY:

Police Detail: Y / Items: _____

APPROVED: [Signature] DATE: 9/12/18
Chief of Police

Please return to the Highway Department to be placed on the Town Board Workshop

Workshop Agenda Date: _____ Approved On: _____ TBR #: _____

RECEIVED

18-5A51

SEP 12 2018

TOWN OF ORANGETOWN
HIGHWAY DEPARTMENT

Pearl River Middle School PTA
Pearl River Middle School
520 Gilbert Avenue
Pearl River, New York

Highway Department
Town of Orangetown
26 W. Orangeburg Road
Orangeburg, New York 10962

Re: Requested Use of Traffic Cones & Barricades 9/23/18 (inclement weather date of 9/30)

Dear Highway Department:

On Sunday, September 23, 2018, the Pearl River Middle School PTA is hosting a Color Splash (a fun walk/run) solely on the grounds of the Pearl River Middle School and its connecting/adjacent neighbor, the Pearl River Nauraushaun Swim Club. We are writing to request your assistance. Last year, we had requested that the Town close certain of the roads leading from the High School to the Middle School and the Town granted that request. This year, however, we have moved the course to the grounds of our school.

We will not be walking or running on any of the Town's roads. We have mapped out a route from the parking lot of Nauraushaun, through the trail that connects Nauraushaun to the middle school, and lapping in and around the Middle School grounds. Our course is less than two miles, but because it laps around the Middle School a few times, we are in need of some cones that will help us line our trail for our participants.

Therefore, we were wondering if the Highway Department would be willing to loan us the use of your cones once again please? We also wondered if the Highway Department would be willing to help us barricade the entrance and exit to our Middle School, if possible. With Nauraushaun's permission, we are instructing all participants to park in Nauraushaun's parking lot.

In the event that the Highway Department is able to grant our request, we did have the Town of Orangetown listed as an additional insured on our Certificate of Liability Insurance policy that we had purchased for the Color Splash (see attached).

Very truly yours,
Suzanne Finnegan
Pearl River Middle School PTA

AWY.

Barricades @ Nauraushaun parking lot



CERTIFICATE OF LIABILITY INSURANCE

DATE (MM/DD/YYYY)
09/11/2018

THIS CERTIFICATE IS ISSUED AS A MATTER OF INFORMATION ONLY AND CONFERS NO RIGHTS UPON THE CERTIFICATE HOLDER. THIS CERTIFICATE DOES NOT AFFIRMATIVELY OR NEGATIVELY AMEND, EXTEND OR ALTER THE COVERAGE AFFORDED BY THE POLICIES BELOW. THIS CERTIFICATE OF INSURANCE DOES NOT CONSTITUTE A CONTRACT BETWEEN THE ISSUING INSURER(S), AUTHORIZED REPRESENTATIVE OR PRODUCER, AND THE CERTIFICATE HOLDER.

IMPORTANT: If the certificate holder is an ADDITIONAL INSURED, the policy(ies) must have ADDITIONAL INSURED provisions or be endorsed. If SUBROGATION IS WAIVED, subject to the terms and conditions of the policy, certain policies may require an endorsement. A statement on this certificate does not confer rights to the certificate holder in lieu of such endorsement(s).

PRODUCER Albert Palancia Agency, Inc. PO Box 26 Mamaroneck, NY 10543	CONTACT NAME: BENJAMIN J PALANCIA	
	PHONE (A/C No, Ext): (914)698-1373 FAX (A/C No): (914)698-0125 E-MAIL ADDRESS: ben@palanciainsurance.com	
INSURED PEARL RIVER MIDDLE SCHOOL PTA AND PEARL RIVER HIGH SCHOOL DBA COLOR RUN 275 EAST CENTRAL AVENUE PEARL RIVER, NY 10965	INSURER(S) AFFORDING COVERAGE	NAIC #
	INSURER A: UNITED STATES LIABILITY INSURANCE GROUP	25895
	INSURER B:	
	INSURER C:	
	INSURER D:	
	INSURER E:	

COVERAGES CERTIFICATE NUMBER: 00000000-32000 REVISION NUMBER: 4

THIS IS TO CERTIFY THAT THE POLICIES OF INSURANCE LISTED BELOW HAVE BEEN ISSUED TO THE INSURED NAMED ABOVE FOR THE POLICY PERIOD INDICATED. NOTWITHSTANDING ANY REQUIREMENT, TERM OR CONDITION OF ANY CONTRACT OR OTHER DOCUMENT WITH RESPECT TO WHICH THIS CERTIFICATE MAY BE ISSUED OR MAY PERTAIN, THE INSURANCE AFFORDED BY THE POLICIES DESCRIBED HEREIN IS SUBJECT TO ALL THE TERMS, EXCLUSIONS AND CONDITIONS OF SUCH POLICIES. LIMITS SHOWN MAY HAVE BEEN REDUCED BY PAID CLAIMS.

INSR LTR	TYPE OF INSURANCE	ADDL INSD	SUBR WVD	POLICY NUMBER	POLICY EFF (MM/DD/YYYY)	POLICY EXP (MM/DD/YYYY)	LIMITS
A	<input checked="" type="checkbox"/> COMMERCIAL GENERAL LIABILITY <input type="checkbox"/> CLAIMS-MADE <input checked="" type="checkbox"/> OCCUR	Y		CL 1769631	09/23/2018	09/20/2016	EACH OCCURRENCE \$ 1,000,000 DAMAGE TO RENTED PREMISES (Ea occurrence) \$ 100,000 MED EXP (Any one person) \$ 1,000 PERSONAL & ADV INJURY \$ 1,000,000 GENERAL AGGREGATE \$ 2,000,000 PRODUCTS - COMP/OP AGG \$ Excluded
	GEN'L AGGREGATE LIMIT APPLIES PER: <input checked="" type="checkbox"/> POLICY <input type="checkbox"/> PRO-JECT <input type="checkbox"/> LOC OTHER:						
	AUTOMOBILE LIABILITY <input type="checkbox"/> ANY AUTO <input type="checkbox"/> OWNED AUTOS ONLY <input type="checkbox"/> SCHEDULED AUTOS <input type="checkbox"/> HIRED AUTOS ONLY <input type="checkbox"/> NON-OWNED AUTOS ONLY						COMBINED SINGLE LIMIT (Ea accident) \$ BODILY INJURY (Per person) \$ BODILY INJURY (Per accident) \$ PROPERTY DAMAGE (Per accident) \$
	UMBRELLA LIAB <input type="checkbox"/> OCCUR EXCESS LIAB <input type="checkbox"/> CLAIMS-MADE DED RETENTION \$						EACH OCCURRENCE \$ AGGREGATE \$
	WORKERS COMPENSATION AND EMPLOYERS' LIABILITY ANY PROPRIETOR/PARTNER/EXECUTIVE OFFICER/MEMBER EXCLUDED? (Mandatory in NH) If yes, describe under DESCRIPTION OF OPERATIONS below	Y/N	N/A				PER STATUTE OTH-ER E.L. EACH ACCIDENT \$ E.L. DISEASE - EA EMPLOYEE \$ E.L. DISEASE - POLICY LIMIT \$

DESCRIPTION OF OPERATIONS / LOCATIONS / VEHICLES (ACORD 101, Additional Remarks Schedule, may be attached if more space is required)
PEARL RIVER SCHOOL DISTRICT, TOWN OF ORANGETOWN & PEARL RIVER NAURASHAUN SWIM CLUB ARE INCLUDED AS ADDITIONAL INSURED WITH RESPECTS TO THE GENERAL LIABILITY AS REQUIRED BY WRITTEN CONTRACT.

CERTIFICATE HOLDER Pearl River Middle School PTA Pearl River High School PTSA 520 Gilbert Avenue Pearl River, New York 10965	CANCELLATION SHOULD ANY OF THE ABOVE DESCRIBED POLICIES BE CANCELLED BEFORE THE EXPIRATION DATE THEREOF, NOTICE WILL BE DELIVERED IN ACCORDANCE WITH THE POLICY PROVISIONS.
	AUTHORIZED REPRESENTATIVE (BJP)

Route

18-SD-51

Starting line at Naurashaun swim club parking lot.

Participants proceed on path in woods to Pearl River Middle School property. Continue along path around to back of middle school. Circle twice around middle school property . Finishline by baseball fields at Pearl River Middle School.

PTA Color Run
September 23, 2018
9am - 2pm

RECEIVED

SEP 18 2018

TOWN OF ORANGETOWN
HIGHWAY DEPARTMENT

RECEIVED

SEP - 7 2018

TOWN OF ORANGETOWN
HIGHWAY DEPARTMENT

TOWN OF ORANGETOWN
SPECIAL USE PERMIT FOR USE OF TOWN PROPERTY/ITEMS

PERMIT # 18-SP-50

RECEIVED

SEP 14 2018

Orangetown Police Department

EVENT NAME: Escape New York

APPLICANT NAME: Gilbert Yang on behalf of the New York Cycle Club

ADDRESS: 163 East 81st Street, Apt 6A

PHONE #: _____ CELL # 917-783-8200 FAX # _____

CHECK ONE: PARADE _____ RACE/RUN/WALK OTHER _____

The above event will be held on September 22, 2018 from 8 AM to 3 PM RAIN DATE: None

Location of event: See attached maps

Sponsored by: New York Cycle Club Telephone #: _____

Address: c/o Gilbert Yang, 163 East 81st street, Apt 6a, New York, NY 10028

Estimated # of persons participating in event: 1200 bicyclists vehicles 1 or 2

Person (s) responsible for restoring property to its original condition: Name-Address-Phone #:

Applicant above on behalf of the New York Cycle Club

Signature of Applicant: Gilbert Yang Date: 9/7/18

GENERAL INFORMATION REQUIRED: (HIGHWAY/PARKS/POLICE)

Letter of Request to Town Board requesting aid for event - Received On: 9.7.18

Certificate of Insurance - Received On: 9.7.18

FOR HIGHWAY DEPARTMENT USE ONLY:

Road Closure Permit: Y (N) Received On: _____

Rockland County Highway Dept. Permit: Y (N) - Received On: 9.4.18

NYS DOT Permit: Y (N) - Received On: _____

Route/Map/Parking Plan: Y (N) - Received On: 9.7.18

RFS #: BARRICADES: Y (N) CONES: Y (N) TRASH BARRELS: Y (N) OTHER: Road Use Only

APPROVED: James [Signature] DATE: 9.13.18
Superintendent of Highways

FOR PARKS & RECREATION DEPARTMENT USE ONLY:

Show Mobile: Y (N) Application Required: Fee Paid - Amount/Check # _____

Port-o-Sans: Y (N) Other: Use of Joseph B. Clarke Paul Trail

APPROVED: A.T. [Signature] DATE: 9/13/18
Superintendent of Parks & Recreation

FOR POLICE DEPARTMENT USE ONLY:

Police Detail: Y (N) Items: _____

APPROVED: SC [Signature] DATE: 9/14/18
Chief of Police

** Please return to the Highway Department to be placed on the Town Board Workshop **

Workshop Agenda Date: _____ Approved On: _____ TBR #: _____

RECEIVED

SEP 17 2018

TOWN OF ORANGETOWN
HIGHWAY DEPARTMENT

18-SP-50

RECEIVED

SEP -- 7 2018

TOWN OF ORANGETOWN
HIGHWAY DEPARTMENT

New York Cycle Club
Escape New York
% Gilbert Yang, Routes Director
163 East 81st Street, Apt. 6A
New York, NY 10028

Town Board
Town of Orangetown
26 W Orangeburg Rd,
Orangeburg, NY 10962

Respected members of the Orangetown Town Board,

I am writing to request permission to use town roads on September 22, 2018 between the hours of 8 AM to 3 PM for a charity bicycle ride hosted by the New York Cycle Club. I am in charge of planning the routes for the 2018 ride.

Our ride begins at 7 AM in Manhattan and the first participants should reach the Town of Orangetown at about 8 AM. We anticipate a total of 1,200 riders, with starts staggered throughout the morning to ensure a smooth flow of rider traffic and for safety. Riders generally will be passing through the town in small groups and we will have marshals positioned along the route to ensure rider safety. We are not requesting any road closures or police support.

In the attachments I have provided you detailed route information with turn by turn instructions and detailed maps for the routes that pass through the Town.

Escape New York is a charity ride. Proceeds benefit I Challenge Myself and Recycle-a-Bicycle's Kids Ride Club, two charities that help local at-risk youth through cycling, healthy living, and nutrition. New York Cycle Club itself is a not-for-profit recreational club.

We have been holding this event for over 20 years, and we hope to maintain strong and cordial relationships with the communities through which we travel.

I have returned the Special Use Permit Application in a separate attachment and will shortly provide the requisite COI. Please do not hesitate to contact me with any questions, and let me know if any further information is needed.

Sincerely yours,

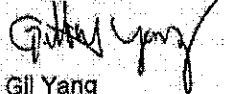

Gil Yang
Routes Director
Escape New York 2018



CERTIFICATE OF LIABILITY INSURANCE

DATE (MM/DD/YYYY)
09/07/2018

18-SP-50

THIS CERTIFICATE IS ISSUED AS A MATTER OF INFORMATION ONLY AND CONFERS NO RIGHTS UPON THE CERTIFICATE HOLDER. THIS CERTIFICATE DOES NOT AFFIRMATIVELY OR NEGATIVELY AMEND, EXTEND OR ALTER THE COVERAGE AFFORDED BY THE POLICIES BELOW. THIS CERTIFICATE OF INSURANCE DOES NOT CONSTITUTE A CONTRACT BETWEEN THE ISSUING INSURER(S), AUTHORIZED REPRESENTATIVE OR PRODUCER, AND THE CERTIFICATE HOLDER.

IMPORTANT: If the certificate holder is an ADDITIONAL INSURED, policy(ies) must have ADDITIONAL INSURED provisions or be endorsed. If SUBROGATION IS WAIVED, subject to the terms and conditions of the policy, certain policies may require an endorsement. A statement on this certificate does not confer rights to the certificate holder in lieu of such endorsement(s).

PRODUCER American Specialty Insurance & Risk Services, Inc. dba A S Insurance & Risk Services Agency 7609 W. Jefferson Blvd., Suite 100 Fort Wayne IN 46804		CONTACT NAME: PHONE (A/C, No, Ext): 260-969-5203 FAX (A/C, No): 260-969-4729 E-MAIL ADDRESS: INSURER(S) AFFORDING COVERAGE INSURER A: Arch Insurance Company INSURER B: INSURER C: INSURER D: INSURER E: INSURER F:		NAIC # 11150
--	--	--	--	------------------------

SEP - 7 2018

TOWN OF ORANGETOWN
HIGHWAY DEPARTMENT

COVERAGES	CERTIFICATE NUMBER: 1001600740	REVISION NUMBER:
------------------	---------------------------------------	-------------------------

THIS IS TO CERTIFY THAT THE POLICIES OF INSURANCE LISTED BELOW HAVE BEEN ISSUED TO THE INSURED NAMED ABOVE FOR THE POLICY PERIOD INDICATED. NOTWITHSTANDING ANY REQUIREMENT, TERM OR CONDITION OF ANY CONTRACT OR OTHER DOCUMENT WITH RESPECT TO WHICH THIS CERTIFICATE MAY BE ISSUED OR MAY PERTAIN, THE INSURANCE AFFORDED BY THE POLICIES DESCRIBED HEREIN IS SUBJECT TO ALL THE TERMS, EXCLUSIONS AND CONDITIONS OF SUCH POLICIES. LIMITS SHOWN MAY HAVE BEEN REDUCED BY PAID CLAIMS.

INSR LTR	TYPE OF INSURANCE	ADDL INSD	SUBR WVD	POLICY NUMBER	POLICY EFF (MM/DD/YYYY)	POLICY EXP (MM/DD/YYYY)	LIMITS
A	<input checked="" type="checkbox"/> COMMERCIAL GENERAL LIABILITY <input type="checkbox"/> CLAIMS-MADE <input checked="" type="checkbox"/> OCCUR GEN'L AGGREGATE LIMIT APPLIES PER: <input type="checkbox"/> POLICY <input type="checkbox"/> PROJECT <input type="checkbox"/> LOC <input checked="" type="checkbox"/> OTHER: CLUB	Y		SBCGL0054501	02/01/2018	02/01/2019	EACH OCCURRENCE \$ 1,000,000
	DAMAGE TO RENTED PREMISES (Ea occurrence) \$ 1,000,000						
							MED EXP (Any one person) \$ Excluded
							PERSONAL & ADV INJURY \$ 1,000,000
							GENERAL AGGREGATE \$ 5,000,000
							PRODUCTS - COMP/OP AGG \$ 5,000,000
							\$
	AUTOMOBILE LIABILITY <input type="checkbox"/> ANY AUTO <input type="checkbox"/> OWNED AUTOS ONLY <input type="checkbox"/> SCHEDULED AUTOS NON-OWNED AUTOS ONLY <input type="checkbox"/> HIRED AUTOS ONLY						COMBINED SINGLE LIMIT (Ea accident) \$
							BODILY INJURY (Per person) \$
							BODILY INJURY (Per accident) \$
							PROPERTY DAMAGE (Per accident) \$
							\$
	UMBRELLA LIAB <input type="checkbox"/> OCCUR EXCESS LIAB <input type="checkbox"/> CLAIMS-MADE DED <input type="checkbox"/> RETENTION \$						EACH OCCURRENCE \$
							AGGREGATE \$
							\$
	WORKERS COMPENSATION AND EMPLOYERS' LIABILITY ANY PROPRIETOR/PARTNER/EXECUTIVE OFFICER/MEMBER EXCLUDED? (Mandatory in NH) If yes, describe under DESCRIPTION OF OPERATIONS below	Y/N	N/A				PER STATUTE OTH-ER
							E.L. EACH ACCIDENT \$
							E.L. DISEASE - EA EMPLOYEE \$
							E.L. DISEASE - POLICY LIMIT \$

DESCRIPTION OF OPERATIONS / LOCATIONS / VEHICLES (ACORD 101, Additional Remarks Schedule, may be attached if more space is required)
- Coverage applies to NEW YORK CYCLE CLUB, INC., 551 FIFTH AVENUE, ROOM 422, NEW YORK, NY 10176.

- The Certificate Holder shall be an Additional Insured, but only with respect to the operations of the Named Insured, and subject to the provisions and limitations of Form 00S GL002900 Additional Insured - Designated Person or Organization Written Contract or Written Agreement, but only with respect to ESCAPE NEW YORK on September 22, 2018.

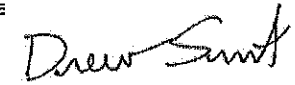
CERTIFICATE HOLDER Town of Orangeburg 26 Orangeburg Road Orangeburg NY 10962	CANCELLATION SHOULD ANY OF THE ABOVE DESCRIBED POLICIES BE CANCELLED BEFORE THE EXPIRATION DATE THEREOF, NOTICE WILL BE DELIVERED IN ACCORDANCE WITH THE POLICY PROVISIONS. AUTHORIZED REPRESENTATIVE 
--	---

18-SP-50

RECEIVED

SEP 04 2018

TOWN OF ORANGETOWN
HIGHWAY DEPARTMENT



**COUNTY OF ROCKLAND
DEPARTMENT OF HIGHWAYS**

23 New Hempstead Road
New City, New York 10956
(845) 638-5060
Fax. (845) 638-5037

C. SCOTT VANDERHOEF
County Executive

CHARLES H. VEZZETTI
Superintendent of Highways

PERMIT AND NOTICE TO Use A ROAD

gil yang 88@gmail.com

To the Town Clerk of *Orangetown* in Rockland County:

This is to certify that the Superintendent of Highways of Rockland County has been requested by
NYCC (New York Cycle Club @ Monica Miller and Gil Yang @ 917-783-8200)

To Use a section of Highway in the Town of *Orangetown* Rockland County, known as
Cherry Lane,, Spook Rock Rd., Grandview Ave., Calls Hollow Road, Blanchard Road, Bulsontown Road, RR Ave
Mott Farm Rd. Tomkins Rd. Beach Rd, Straw town Rd, Congers Rd, Kings Hwy., Western Hwy. Old Tappan Rd.

The portion of highway will be Used under Highway Law on Sept. 22, 2018 Sat. from 8 am - 2 pm
For the purpose of NYCC (New York Cycle Club) " Escape New York " 50 / 100 Mile Routes ROAD USE ONLY
This activity can not be properly conducted unless the portion described above is Used during the time such activity is in progress.

To the Town Highway Superintendent of *Orangetown* in Rockland County:

A certificate of which the foregoing is a copy having been executed by me under the authority conferred by Section 104 of the Highway Law and filed in the office of the Town Clerk in *Orangetown* on the 4th Day of September 2018, you are hereby notified that I have authorized the Use of the above described section of highway. The applicant must provide a detour for traffic during the time the road is Used and notify police, fire, ambulance, school districts and public transportation prior to Using of the roadway. The applicant must provide the necessary signs, barricades, lights, flagmen, etc. and make every effort to cooperate with the traveling public. Keep fire, police, ambulance, public transportation and school entities informed as to daily activities, concerning the Use.

Dated this 4th September 2018



Rockland County Superintendent of Highways

2/2/18

18-50-50

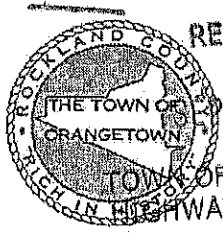

RECEIVED

12 2018

Town of Orangetown
Department of Parks, Recreation & Building Maintenance
81 Hunt Road, Orangeburg, NY 10962
Office: (845) 359-6503 Fax: (845) 359-6991
recreation@orangetown.com



APPLICATION FOR USE OF TOWN ATHLETIC FACILITIES

Organization Name: New York Cycle Club, (501c7) Date of Request: September 12, 2018

Residency: Youth Resident Youth Non-Resident
 Adult Resident Adult Non-Resident

To be considered a "resident organization," 65% of the participating members must be residents of the Town of Orangetown. An organizations/groups residency is determined by the total population of registered participants for the full previous operating year. Registration lists/rosters are required.

There will be a non-resident fee equal to 10% of the cost of enrollment in the program made payable to the Town within one month following the close of registration.

Orangetown Youth Athletic Groups consisting of fifty (50) or more participants must provide proof of the organizations tax exempt status in the form of a N.Y.S. certificate of not-for-profit status under the N.Y.S. not-for-profit corporation and copies of N.Y.S. and/or Federal tax returns or other required filings, documenting governmental recognition of the group's/organization's non-profit status on an annual basis, within 60 days of the applicable State and Federal filing deadline.

Permits are not valid until a certificate of insurance has been received. Minimum Insurance required: Bodily Injury - \$1,000,000.00. Aggregate - \$3,000,000.00. Property Damage Liability - \$100,000.00. Certificate must state: **"The Town of Orangetown is an additional named insured."**

Facilities Requested:

Name of Park or Facility	Date(s)	Days of the Week	Times
<u>Joseph B. Clarke Rail Trail</u>	<u>September 22, 2018</u>	<u>Sunday</u>	<u>8 AM to 3 PM</u>

Purpose of facility request (provide detail): Charity Bicycle Ride, "Escape New York", "ENY"

Will admission/fees be charge: yes Purpose of Proceeds: Charity youth organizations

Additional service requested: None

If a permit is granted, the applicant agrees to comply with the Town of Orangetown Code Section 7A, as well as all rules and regulations herewith. Any applicable permitting fees will be due at the time of acceptance.

Applicant Name: Gilbert Yang, Routes Director ENY 2018 E-Mail: ENYroutes@nycc.org

Address: 163 East 81st Street, Apt 6A, NY, NY

Telephone #: 917-783-8200 (Mobile) _____ (Home)

Signature of Applicant: Gilbert Yang

Office Use Only

Department Approval: [Signature] Date: 9/13/18 Fee Due: —

Payment COI Proof of Residency Not for Profit Documents

PROFESSIONAL SERVICES CONTRACT (EMPLOYEE ASSISTANCE PROGRAM)

THIS AGREEMENT, made and executed as of this 1st day of October 2018 between Montefiore Nyack Hospital (the "Hospital") a non-profit acute care hospital located at 160 N. Midland Avenue, Nyack, NY 10960 and the Town of Orangetown (the "Company").

WITNESSETH

WHEREAS, the Hospital provides Employee Assistance Programs to outside Employers;
and

WHEREAS, the Company is in need of such programs for its employees; and

WHEREAS, it is the desire of the Hospital and the Company to agree on the terms pursuant to which Hospital will provide such Services to Company;

NOW, THEREFORE, in consideration of the mutual covenants and conditions herein contained and other good and valuable consideration, the receipt and sufficiency of which are hereby acknowledged, the Hospital and the Company agree as follows:

1. SERVICES

The Hospital shall provide the following services:

- A) Annual All employee Orientation Meetings to promote the program.
- B) Annual Supervisory Training sessions to inform and educate managers to the Employee Assistance Program's Supervisory Referral process.
- C) All promotional materials including, but not limited to, Employee Assistance Program posters, brochures, paycheck stuffers, employee promotional letter and other promotional correspondence.
- D) Professional assessment, consultation and referral services as necessary to troubled employees and/or their families.
- E) Quarterly reports to designated individuals to include utilization rates and other non-identifying demographic information.
- F) Monthly reports to designated individuals of all employees referred by Supervisors for poor job performance (Supervisory Referrals) indicating whether the employee is or is not in treatment. No further details will be provided unless the employee in treatment signs an appropriate release.

Other services not covered herein must be separately negotiated by the parties.

2. TERM OF AGREEMENT AND TERMINATION

This Agreement shall commence as of the 1st day of October 2018 and shall continue in full force and effect for a period of one year(s). Said term shall automatically be extended for successive one (1) year periods thereafter unless terminated by either party hereto as permitted by the terms of this Agreement. Either party may terminate this Agreement by giving not less than thirty (30) days prior written notice of the

intention to terminate this Agreement, unless the parties mutually consent to a shorter notice period or as otherwise set forth herein.

3. COMPENSATION FOR SERVICES

Company shall pay Hospital for Services rendered in accordance with the fee schedule attached hereto as Exhibit A, and incorporated herein by reference.

4. GENERAL PROVISIONS

- A. **Indemnity.** Company and Hospital agree to indemnify, defend and hold harmless the other party, including, as applicable, its shareholders, officers, directors, employees and agents, from and against any and all liabilities, losses, damages, claims, causes of action and expenses ~~(including reasonable attorney's fees)~~, whenever arising or incurred, that are caused or asserted to have been caused, directly or indirectly, by or as a result of the acts or omissions of that party, its officers, directors, employees and/or agents and/or such party's breach of this Agreement. The indemnification provided under this paragraph shall supplement and not supersede or replace any protection or rights that may be afforded to either party under any insurance policies maintained by the parties that provide coverage for an act that may serve as a basis for a claim of indemnification hereunder.
- B. **Compliance with Law.** The Hospital and the Company shall each comply with all applicable federal, state and local laws, regulations and policies with respect to the performance of this agreement, including, but not limited to, rights relative to confidentiality, privacy, quality of care rendered, consumer protection and the like.
- C. **Governing Law.** This Agreement shall be interpreted, construed and enforced in accordance with the laws of the State of New York applied without giving effect to any conflict-of-laws principles.

D. Modifications. This instrument contains the entire agreement of the parties and supersedes any and all prior agreements between the parties, written or oral, with respect to the transactions contemplated hereby. The Agreement may not be changed or terminated orally but may only be changed by a written agreement signed by the parties against whom enforcement of any waiver, change, modification, extension, discharge, or termination is sought.

E. Notices. Any notice required or permitted hereunder or any agreement or document executed and delivered in connection with this Agreement shall be deemed to have been served properly if hand delivered to an authorized representative or recipient or mailed by certified or registered United States mail or by overnight express, postage or charges prepaid, or by facsimile if such facsimile transmission permits confirmation to the addresses or facsimile numbers listed below, and properly addressed to the respective party to whom such notices relate at the following address:

IF TO COMPANY:

Town of Orangetown
Orangetown Town Hall
26 Orangeburg Road
Orangeburg, NY 10962
Attention: Donna Morrison, Human Resources Coordinator

IF TO HOSPITAL:

Montefiore Nyack Hospital
Employee Assistance Program
One Blue Hill Plaza – 6th floor
Suite 1608
Pearl River, NY 10965
Attn: Susan Mazzarella, LCSW, CEAP, SAP
Director, Employee Assistance Program

- F. Confidential and Proprietary Information.** It is expressly understood that the systems, methods, procedures, policies, manuals, other written materials and controls, developed or employed by Hospital and Company in the performance of this Agreement are proprietary in nature, shall remain the property of the Hospital or Company and shall not, at any time, be utilized, distributed, copied, or otherwise employed or acquired by the other party except during the term of this Agreement, unless prior written approval is obtained from the party owning the information. *This provision shall survive the termination of this Agreement.*
- G. Non Discrimination.** Both parties to this Agreement shall comply with all applicable federal, state, and local laws and regulations, in that no person shall, on the grounds of race, color, creed, religion, sexual orientation, national origin, age, sex, marital status, blindness, source of payment or sponsorship, or disability, be excluded from participation in, be denied benefits of, or otherwise be subjected to discrimination under any program, service, employment relationship, or activity offered by either party.
- H. Assignment and Binding Effect.** Neither party shall have the right to assign or delegate its obligations hereunder without the prior written consent of the other party. Notwithstanding, the foregoing, all covenants, conditions, and obligations contained herein shall be binding upon, and shall inure to the benefit of permitted successors and assigns of Company and Hospital.
- I. NYCRR400.4** Notwithstanding any other provision in this Agreement, each party remains responsible for ensuring that any service provided by it pursuant to this Agreement complies with all pertinent provisions of Federal, State and local statutes, rules and regulations.

IN WITNESS WHEREOF, the parties hereto have executed this Agreement as of the date and year first written above.

Montefiore Nyack Hospital

Town of Orangetown

By _____
Mark Geller, MD, President & CEO

By _____
Chris Day, Town Supervisor

Date _____

Date _____

TOWN OF ORANGETOWN:

EXHIBIT A

FEE SCHEDULE

**EAP SERVICES FOR CONTRACT YEAR BEGINNING ON
OCTOBER 1, 2018 AND ENDING ON SEPTEMBER 30, 2019
CONTRACT FEE.....\$11,352.00**

(Fee for 264 Employees)

to be paid within 45 days of receipt of invoice

BECKMANN APPRAISALS, Inc.

67 MAIN STREET

TAPPAN, NEW YORK 10983

REAL PROPERTY APPRAISERS, ANALYSTS AND CONSULTANTS

William R. Beckmann, MAI, CRE, FRICS, Certified General Real Estate Appraiser

(845) 359-0070

Mona Parker, Certified General Real Estate Appraiser

fax (845) 359-3652

Ann Marie Mulholland, Certified General Real Estate Appraiser

www.beckmannappraisals.com

Poh Sim Lim Png, Certified General Real Estate Appraiser

REVISED

Via Email Only

rmagrino@orangetown.com

September 17, 2018

Town of Orangetown
Office of the Town Attorney
Robert V. Magrino, Esq.
26 Orangeburg Road
Orangeburg, New York 10962

RE: Hunt Road, Orangeburg
AKA Pearl River Sewer District
Tax ID #73.15-1-17

Dear Mr. Magrino:

This letter will serve as our proposal and, provided it is accepted by you within thirty days of this date, our letter of agreement to appraise the real property noted above for the purpose of determining the fee simple fair market value. The purpose of the appraisal is to estimate value of the land only, as if vacant, and for no other use or purpose. It is our understanding the subject property is approximately 10.06 acres of land in the hamlet of Pearl River, Town of Orangetown, Rockland County, New York.

Our analysis will be prepared in conformity with the Code of Professional Ethics, the Standards of Professional Appraisal Practice, and the Supplemental Standards of Professional Appraisal Practice of the Appraisal Institute as well as the Uniform Standards of the Professional Appraisal Foundation. Our analysis also may be subject to any special assumptions and limiting conditions which may become apparent during the course of the assignment.

You and/or the client shall be required to cooperate with us and promptly provide to us, on request, all information and data reasonably required by us to prepare our evaluation, including surveys and access to inspect the property.

Our fee for the professional services in preparation of our analysis described above for a Restricted appraisal is \$5,000 to be paid upon completion of the reports. In the event you determine that an easement will be placed on the subject property, and the nature and extent of the easement is provided to us within 6 months of the valuation date, we will provide the appraised value of the easement at an additional fee of \$2,500.

If these arrangements are satisfactory, you may authorize the assignment by signing this letter as accepted and returning it, after which our professional services shall commence.

We appreciate your consideration of our firm and look forward to working with you on this assignment.

Very truly yours,



William R. Beckmann, MAI, CRE

Accepted by Robert V. Magrino, Esq. on behalf of the Town of Orangetown



N.Y.S. SWAT OPERATOR **COURSE**

Orange County, NY

October 1- October 26, 2018

(Monday-Friday only, 0800 Start every day unless otherwise noted)

There is a Pre-Requisite form that each agency must complete with applicants prior to the course. We will provide this form via email. Any agency that does not have a DCJS certified PT or Range instructors can contact us to have the tests administered on a *separate date* prior to the course. This form will be collected on Day 1 of the course.

The Orange County Sheriff's Office under the auspices of NYS DCJS will be conducting the SWAT Operator Course at All Classes will be held at the Orange County Fire Training Center, 9 Training Center Lane, New Hampton, NY 10958. Orange County, New York.



This is a **SWAT** (Special Weapons And Tactics) course being run by **SWAT** Operators. Students should expect the fast paced, in depth and physically demanding training worthy of the pride of their employing agencies.

Officers that complete this course will receive NYS Department of Criminal Justice Services (DCJS) Certification.

This in-depth program teaches basics in many areas of Tactical Operations including:
Firearms, Warrant Service, Hostage Rescue, Room Clearing, Vehicle Assaults,
Land Navigation, Rural Operations, Priority of Life, Tactical Medicine, Defensive Tactics &
various other topics. This course will take place in a classroom & live fire range setting.
Participating Officers should expect to participate in physical activities, hands on use of
tactical equipment and range exercises while wearing assigned tactical gear.

Attendance will be capped at 16 students.

Pre-Requisites (per DCJS Standards):

- Air Purifying Respirator (Gas Mask)
- Physical Fitness Test: Sit Ups, Push Ups, 1.5 Mile Run (70% Cooper Standards)
- Shooting Proficiency Test – Minimum 90% Score must be achieved.
- Must have PT/ Range forms in hand Day 1
- Course Attire: Tactical Uniform / Training Clothes: BDU Pants, Long Sleeve Shirt, Weather Appropriate Gear (Cold & Rain)

Equipment Needed:

- All Tactical Duty Gear (holster, handgun, 3 HG magazines, flashlight, handcuffs)
 - Tactical Body Armor
- Baseball Cap, Hearing Protection, Clear Eye Protection
 - M4 or Similar Long Gun (3 LG Magazines)
 - FX Marking Gun (if available)
 - 3 Noise Flash Diversionary Devices (NFDD's)
 - Ammunition Needed:
 - o 700 Rounds Handgun Practice Ammunition
 - o 100 Rounds Handgun Service Ammunition
 - o 700 Rounds .223 Practice Ammunition
 - o 300 rounds of FX Marking cartridges (if available)
- Less Lethal Launcher/ Munitions: direct impact, OC and/or CS (if available)

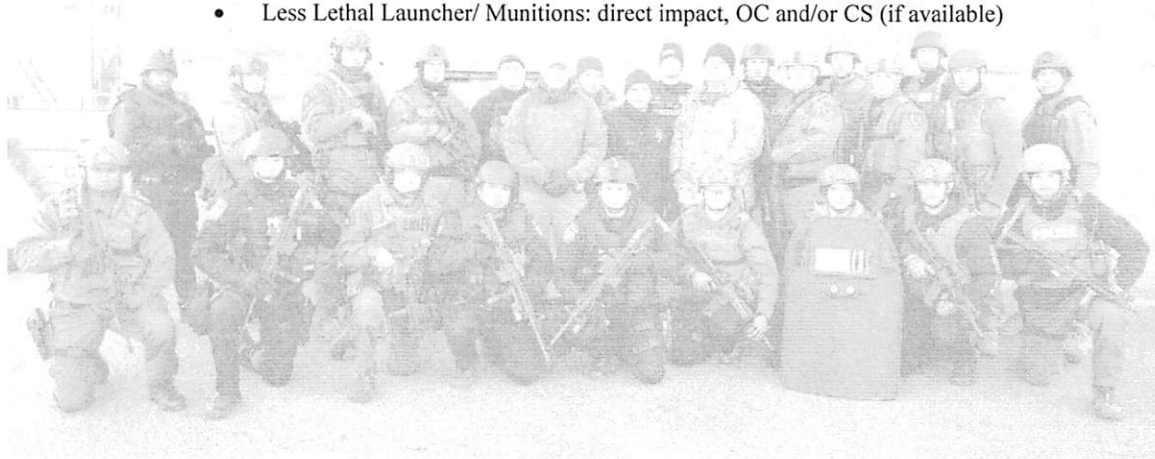

- Course will also include Less Lethal Munitions. Any agency that has expired direct impact, OC or CS munitions, please send for your students to use.

Contact Information/Questions and Registration Completed Through:

Sgt. John W. Trazino

Orange County Special Operations Group

jtrazino@orangecountygov.com

JAMES J. DEAN
Superintendent of Highways
Roadmaster II

Orangetown Representative

R.C. Soil & Water Conservation Dist.-Chairman

Member:

American Public Works Association NY Metro Chapter

NYS Association of Town Superintendents of Highways

Hwy. Superintendents' Association of Rockland County



**HIGHWAY DEPARTMENT
TOWN OF ORANGETOWN**

119 Route 303 • Orangeburg, NY 10962

(845) 359-6500 • Fax (845) 359-6062

E-mail - highwaydept@orangetown.com

SURPLUS EQUIPMENT

<u>Year</u>	<u>Make</u>	<u>Description</u>	<u>VIN/Serial</u>
1985	Ingersoll-Rand	Compressor	145223-U85-179
2008	GMC	C-5500 dump/plow	1GDE5C3978F415193
2009	GMC	C-5500 dump/plow/spreader	1GDE5C3989F408366
2002	Petersen	TT2A dump trailer	1P9T0182511314193
1985	Rayco	RG-1637-A	163701185
1996	CASE	Clam bucket-JRB model 621B	0369-18812B
2008	Solaris	MSA Gas Detector	A597826
2010	Solaris	MSA Gas Detector	A520590

Kj
9/19/18



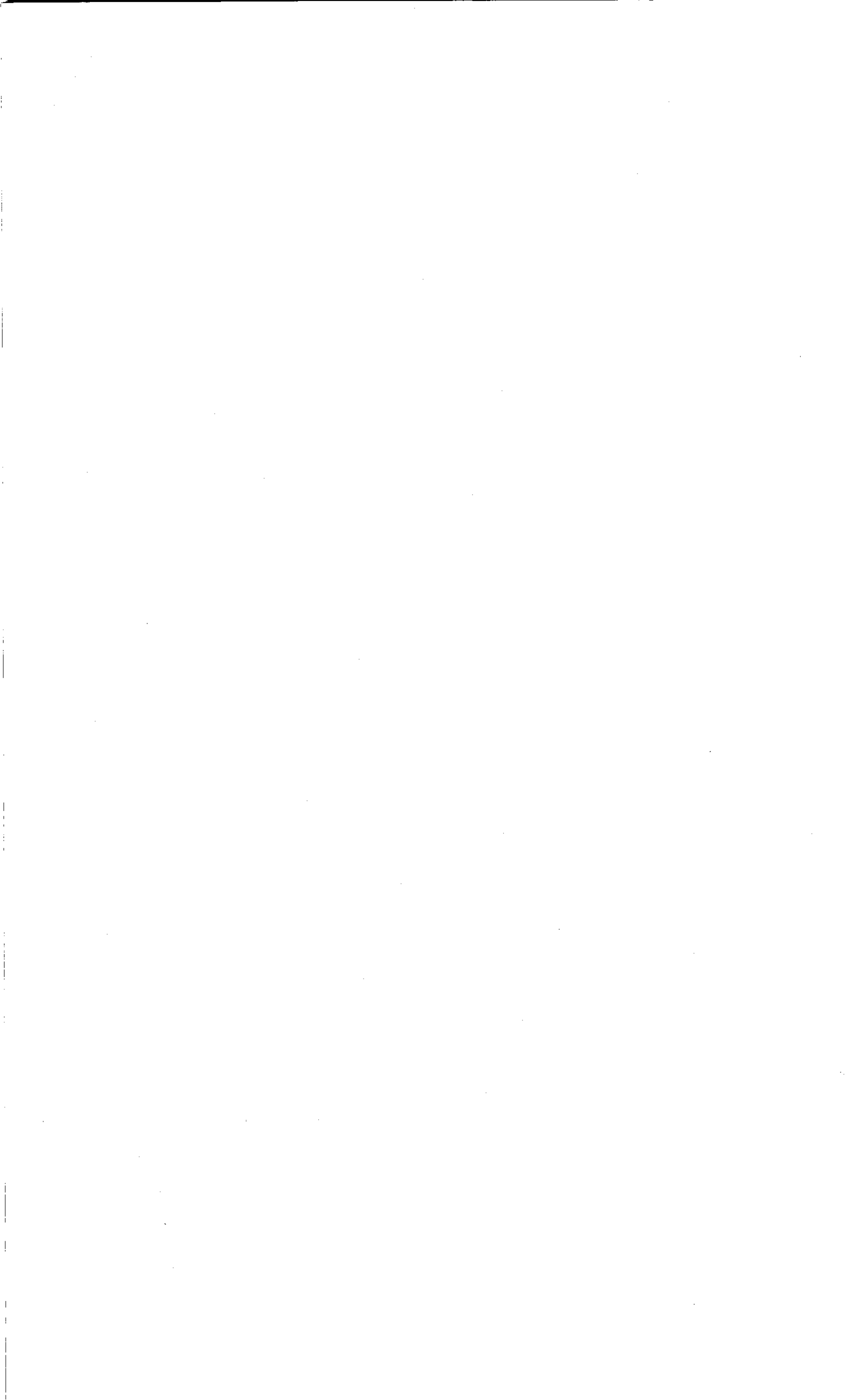

CONTRACTOR NAME & ADDRESS	<i>Schultz Warrent, NY</i>					
DATE RECEIVED	<i>9/12/18</i>					X
TIME RECEIVED	<i>2:01pm</i>					
NON COLLUSION STATEMENT	<input checked="" type="checkbox"/>					
BID BOND or CERTIFIED CHECK	<input checked="" type="checkbox"/>					

One (1) New Light Duty Rack Body Truck						
TOTAL	<i>\$ 57,810</i>	\$	\$	\$	\$	X
						X
						X
						X
						X
						X
						X
						X
						X
						X
						X
						X
						X
						X
						X
						X
						X
						X
						X
						X





Department of Environmental Management and Engineering
Town of Orangetown

127 Route 303 Orangeburg New York 10962
Tel: (845) 359-6502 • Fax: (845) 359-6951

MEMO

Date: September 21, 2018

To: Kimberly Allen, Administrative Secretary

Cc: Amanda Hyland, Confidential Assistant to Supervisor

From: Eamon Reilly, DEME Commissioner

Re: Reclassify SECRETARIAL ASSISTANT II to ADMINISTRATIVE
SECRETARY I / DEME

Please place the following item on the Town Board Agenda for Tuesday, September 25, 2018.

Proposed Text: **RESOLVED**, upon the recommendation of Rockland County Personnel, reclassify the position of Secretarial Assistant II in the D.E.M.E. / Sewer Department, Grade 10 to the position of Administrative Secretary I, Grade 12, effective September 7, 2018.

Proposed Text: **RESOLVED**, Ellen Fordham is hereby appointed to the position of Administrative Secretary I, provisional, in the D.E.M.E. / Sewer Department, Grade 12, Step 8/13 at a salary of \$ 79,092, effective September 7, 2018.

ADMINISTRATIVE SECRETARY I (C)*

P.O. 27

ROCKLAND COUNTY PERSONNEL OFFICE
JOB CLASSIFICATION QUESTIONNAIRE

County, Town, Village or School District Town of Orangetown		Department DEME	Position Title (if established)
This position requires: 35 Hours work per week		12 Months work per year	Rate of Pay \$ 75,511 per year
Persons Supervising this position		(Direct, Occasional, General) TYPE OF SUPERVISION	
NAME		TITLE	
Joseph J. Moran		Commissioner	
Guy DeVincenzo		Deputy	
Michael Weber		Chief Plant Operator	
Persons Supervised by Employee in this position		TYPE OF SUPERVISION	
NAME		TITLE	
Helen Chee		Account Clerk Typist	
		General	
Persons doing substantially the same kind and level of work		LOCATION OF POSITION	
NAME		TITLE	
Karen Jahnes		Administrative Secretary I	
		Highway	
PERCENT OF WORK TIME	DESCRIPTION OF DUTIES: Describe the work in sufficient detail to give a clear work picture of the job. Use a separate paragraph for each kind of work and describe the more important or time-consuming duties first. In the left column, estimate how the total working time is divided.		
	See attached sheet		

The above statements are accurate and complete

Signature: *Ellen Fodha*

Date: 4/25/18

Attach a separate sheet, if more space is needed.

TO BE COMPLETED BY THE APPOINTING OFFICER

Place an mark opposite the item in each group which best describes the work of this position.

- | | |
|--|--|
| <input type="checkbox"/> Repetitive and routine.
<input type="checkbox"/> Routine, but involves some judgment to perform the duties.
<input checked="" type="checkbox"/> Complex, involving decision of order, of tasks and methods.
<input type="checkbox"/> Difficult, involving independent decisions as to scope and planning of projects and programs. | <input type="checkbox"/> Is under direct supervision.
<input checked="" type="checkbox"/> Works according to prescribed procedure with supervision available as needed.
<input type="checkbox"/> Is under general supervision as exercised through reports, conferences and job inspection.
<input type="checkbox"/> Is subject only to policies and administrative approval. |
|--|--|

- | | |
|--|--|
| <input type="checkbox"/> Requires no previous training or special knowledge.
<input type="checkbox"/> Requires some basic abilities or knowledges of the general work.
<input type="checkbox"/> Requires good knowledge of the primary work.
<input type="checkbox"/> Requires thorough knowledge of all phases of the work.
<input checked="" type="checkbox"/> Requires a particular proficiency or skill in a specialized activity. | <input type="checkbox"/> Exercises direct supervision.
<input type="checkbox"/> Supervises, as required, through review of work.
<input type="checkbox"/> Exercises general supervision by means of reports and conferences.
<input checked="" type="checkbox"/> Regularly supervises 1 to 5 employees.
<input type="checkbox"/> Regularly supervises 6 to 15 employees.
<input type="checkbox"/> Regularly supervises over 15 employees. |
|--|--|

What minimum qualifications do you think should be required for this position?

Education: High school 4 years.
 College.....years, with specialization in.....
 Other.....years, with specialization in.....

Experience: (List amount and type)
 2 years 9 months at the position of Secretarial Assistant II

Essential knowledges, skills and abilities:

Type of license or certificate required:

COMMENTS:

*
This is a reclassification of Secretarial Assistant II # 0054.

Signature of appointing officer:

Signature: *[Signature]* Date: 4/25/18

CERTIFICATE OF PERSONNEL OFFICE

In accordance with the provisions of Civil Service Law, Section 22, and the Rockland County Rules, the Rockland County Personnel Office certifies that the appropriate civil service title for the position described is

ADMINISTRATIVE SECRETARY I (Competitive)

Signature: *[Signature]* Date: 9/1/18

ACTION BY LEGISLATIVE BODY OR OTHER APPROVING AUTHORITY IF A NEW POSITION

The new position described by the title indicated in 8 above was established on.....at a salary of \$....., or at salary grade No.

Signature:..... Date:.....

- 56% Supervises and manages the following: the complex InfoTronics Employee Attendance System for a department of 43 employees while making independent decisions with office situations, generates reports for payroll, employee evaluations (e.g. abuse of time, time patterns, tardiness, requests from the Town Attorney's office for personnel information, new enrollees in the Employee Attendance System, time records and reconciliation of time records with the finance department, shift schedules for employees working rotating shifts 24/7 schedule.

Supervises and manages administration duties/activities and independently establishes office priorities to include: Overseeing operations paperwork is organized and submitted in a timely manner, create and implement office policy and procedures, sewer contractors' annual application renewals, manage all sewer and engineering revenue, answering correspondence, , types from notes, composes letters, emails, memo's, advertisements for employment, engineering services, notice to bidders, request for proposals, compliance legal notices, composes Town Board Resolutions on BoardSync program, FOIL requests, notice of claims, maintains files, petty cash, filing, ordering supplies, office equipment operation and repairs.

- 19% Responds to calls, greets the public supervise and manage priorities, makes judgement decisions, answers difficult technical questions with full knowledge of operations and procedures within this department as well as knowledge of other departments and agencies in the Town and County.

- 12% Supervises, manages and maintains confidential personnel records for a department of 43 employees includes: Step increments, contractual raises, infraction notices, work injury reports, supervisor field reports to the Human Resource Department for claims, vehicle accident reports, incident reports/statements, doctor notes required per CSEA contract, communication with workers compensation liaison, workers compensation decisions, time accrual reversals, disciplinary charges and/or work re-assignments. I am the point of contact for all employees providing administrative support for managing and fulfilling employee's queries.

- 13% Statistical data is compiled and calculated for 25 Industrial User's annual permits, monthly flow charges, quarterly monitoring fees, reports are generated along with an invoice then billed.

As per Inter-Municipal Agreement statistical data is compiled for the Village of Upper Nyack's sewer flow to the Town of Orangetown and Pump Station rehabilitation. The Village of Upper Nyack's fees calculated by using a complex equation, a report is generated along with an invoice then billed.

As per the agreement between the Town of Orangetown and the Borough of Rockleigh, New Jersey, the Town shall provide sanitary sewer services to the Borough in exchange for compensation. Data is compiled a report is generated along with an invoice and billed bi-annually.

Ellen Fordham – Secretarial Assistant II – Town of Orangetown

Compiles data using FEMA rates for labor, equipment and materials for any commercial entity or private contractor that causes damage to our infrastructure or requires the Sewer Department to respond



Department of Environmental Management and Engineering
Town of Orangetown

127 Route 303 Orangeburg New York 10962
Tel: (845) 359-6502 • Fax: (845) 359-6951

MEMO

Date: September 21, 2018
To: Kimberly Allen, Administrative Secretary
Cc: Amanda Hyland, Confidential Assistant to Supervisor
From: Eamon Reilly, DEME Commissioner
Re: Award Bid – Van Bortel Ford Inc.

Please place the following item on the Town Board Agenda for Tuesday, September 25, 2018.

Proposed Text: **RESOLVED**, that it is the recommendation of Commissioner of D.E.M.E., Eamon Reilly, that (1) one 2019 Ford Utility Police Interceptor 500A, in the amount of \$ 29,951.40 be awarded to Van Bortel Ford Inc., East Rochester, NY, to be charged to Account G.8130.200 (Special Districts Sewage Treatment Plant. Capital Outlay)

This is Quote # 27936, from 22898 Mini Bid#18080170.



TOWN OF ORANGETOWN

26 ORANGEBURG ROAD
ORANGEBURG, NY 10962
Web Site: www.orangetown.com

PO Number : 51968
Date : 09/13/2018
Page: 1 of 1

Purchase Order

Vendor : 0000005065
VAN BORTEL FORD INC
71 MARSH ROAD
EAST ROCHESTER, NY 14445

Ship To:
TOWN OF ORANGETOWN
26 ORANGEBURG ROAD
ORANGEBURG, NY 10962
Phone # (845) 359-5100

Bill To:
TOWN OF ORANGETOWN
26 ORANGEBURG ROAD
ORANGEBURG, NY 10962
Phone # (845) 359-5100

CONTRACT # NYS MINI BID 18080170 OK BY TB

Description: (2) 2019 FORD UTILITY POLICE INTERCEPTOR 500A

Qty.	Unit	Description	Unit Price	Amount
1.0000	EA	2019 FORD UTILITY POLICE INTERCEPTOR 500A G.8130.200 (SPECIAL DISTRICTS.SEWAGE TREATMENT PLANT.CAPITAL OUTLAY)	29,951.4000	29,951.40
1.0000	EA	2019 FORD UTILITY POLICE INTERCEPTOR 500A H.8130.200.06 (CAPITAL FUND.SEWAGE TREATMENT PLANT.CAPITAL OUTLAY.2018 BONDING)	29,951.4000	29,951.40
Total:				\$59,902.80

I, _____, certify that the above account in the amount of \$ _____ is true and correct; that the items, services and disbursements charged were rendered to or for the municipality, on the dates stated; that no part has been paid or satisfied; that taxes, from which the municipality is exempt, are not included; and that the amount claimed is actually due.

DATE SIGNATURE TITLE

Ordered By: NSCHUTTER Req. Date: 09/13/2018 Req. No: 2012 Approved By: JB,JB

Authorized Official _____ Date _____ Authorized Official _____ Date _____

Thursday September 13th, 2018 2:29 PM



71 Marsh Rd East Rochester, NY 14445 585-586-7705 Fax 585-586-7706

Vehicle Purchase Proposal

Attention: **Frank Peneno**

Purchase Order#:

Town of Orangetown Dept of Environmental Managemen

Quote# 27936

22898 Mini Bid#: 18080170

Phone: 914-906-1208 Fax:

Email: fpeneno@orangetown.com

Item Description	Code	Qty	Your Price	MSRP
2019 Ford Utility Police Interceptor 500A	K8A	1	\$ 29,589.40	\$ 35,940.00
Norsea Blue Metallic	KR	1	\$ 0.00	\$ 0.00
3.7L V6 Ti-VCT FFV Engine	99R	1	\$ 0.00	\$ 0.00
6-Speed Automatic Transmission	44C	1	\$ 0.00	\$ 0.00
License Plate Bracket - Front	153	1	\$ 0.00	\$ 0.00
1st and 2nd row carpet floor covering (incl. floor mats, front and rear)	16C	1	\$ 0.00	\$ 0.00
Dome Lamp - Red/White in Cargo Area	17T	1	\$ 0.00	\$ 0.00
Global Lock / Unlock feature	18D	1	\$ 0.00	\$ 0.00
Engine Block Heater	41H	1	\$ 0.00	\$ 0.00
Spot Lamp - LED Bulb, Driver Only (Unity) includes spot prep	51R	1	\$ 0.00	\$ 0.00
Mirrors - Heated Sideview	549	1	\$ 0.00	\$ 0.00
Remote Keyless-Entry Key FOB	55F	1	\$ 0.00	\$ 0.00
Interior Upgrade Package	65U	1	\$ 0.00	\$ 0.00
Front Console Plate - Delete	85D	1	\$ 0.00	\$ 0.00
Auto Headlamps	86L	1	\$ 0.00	\$ 0.00
Front Headlamp / Police Interceptor Housing Only	86P	1	\$ 0.00	\$ 0.00
Tail Lamp / Police Interceptor Housing Only	86T	1	\$ 0.00	\$ 0.00
Daytime Running Lamps	942	1	\$ 0.00	\$ 0.00
Delivery to Region 5	Reg 5	1	\$ 362.00	\$ 362.00
Term is Net 15 Days A.R.V. Delivery from factory to dealer is estimated at 16-20 weeks. This Quote Expires In 60 Days or final Order date, whichever comes first.	Total Price:		\$ 29,951.40	
Quantity on this Order: 2	Grand Total:		\$ 59,902.80	

To place an order please sign and date this proposal and return it to Van Bortel Ford along with a valid Purchase Order, Voucher, or Letter of Intent. Thank You!

Accepted By: _____ Title _____ Date _____

Van Bortel Ford Inc (WBE) Federal ID 16-1609363 Salesperson: Josh Relyea Quote: 27936

VENDOR #: 5065

Thursday September 13th 2018 2:29 PM



71 Marsh Rd East Rochester, NY 14445 585-586-7705 Fax 585-586-7706

Vehicle Purchase Proposal

Attention: **Frank Peneno**

Purchase Order#:

Town of Orangetown Dept of Environmental Managemen

Quote# 27936

22898 Mini Bid#: 18080170

Phone: 914-906-1208 Fax:
Email: fpeneno@orangetown.com

Item Description	Code	Qty	Your Price	MSRP
2019 Ford Utility Police Interceptor 500A	K8A	1	\$ 29,589.40	\$ 35,940.00
Norsea Blue Metallic	KR	1	\$ 0.00	\$ 0.00
3.7L V6 Ti-VCT FFV Engine	99R	1	\$ 0.00	\$ 0.00
6-Speed Automatic Transmission	44C	1	\$ 0.00	\$ 0.00
License Plate Bracket - Front	153	1	\$ 0.00	\$ 0.00
1st and 2nd row carpet floor covering (incl. floor mats, front and rear)	16C	1	\$ 0.00	\$ 0.00
Dome Lamp - Red/White in Cargo Area	17T	1	\$ 0.00	\$ 0.00
Global Lock / Unlock feature	18D	1	\$ 0.00	\$ 0.00
Engine Block Heater	41H	1	\$ 0.00	\$ 0.00
Spot Lamp - LED Bulb, Driver Only (Unity) includes spot prep	51R	1	\$ 0.00	\$ 0.00
Mirrors - Heated Sideview	549	1	\$ 0.00	\$ 0.00
Remote Keyless-Entry Key FOB	55F	1	\$ 0.00	\$ 0.00
Interior Upgrade Package	65U	1	\$ 0.00	\$ 0.00
Front Console Plate - Delete	85D	1	\$ 0.00	\$ 0.00
Auto Headlamps	86L	1	\$ 0.00	\$ 0.00
Front Headlamp / Police Interceptor Housing Only	86P	1	\$ 0.00	\$ 0.00
Tail Lamp / Police Interceptor Housing Only	86T	1	\$ 0.00	\$ 0.00
Daytime Running Lamps	942	1	\$ 0.00	\$ 0.00
Delivery to Region 5	Reg 5	1	\$ 362.00	\$ 362.00
Term is Net 15 Days A.R.V. Delivery from factory to dealer is estimated at 16-20 weeks. This Quote Expires In 60 Days or final Order date, whichever comes first.	Total Price:		\$ 29,951.40	
Quantity on this Order: 2	Grand Total:		\$ 59,902.80	

To place an order please sign and date this proposal and return it to Van Bortel Ford along with a valid Purchase Order, Voucher, or Letter of Intent. Thank You!

Accepted By: _____ Title _____ Date _____

Van Bortel Ford Inc (WBE) Federal ID 16-1609363 Salesperson: Josh Relyea Quote: 27936

DATE: September 25, 2018

WARRANT

Warrant Reference	Warrant #	Amount
Approved for payment in the amount of		
	081518	\$ 185,939.66
	082118	\$ 213,683.81
	091218	\$ 455,851.48
	092518	\$ 1,690,598.25
		.
	Total	\$ 2,546,073.20

The above listed claims are approved and ordered paid from the appropriations indicated.

APPROVAL FOR PAYMENT

AUDITING BOARD

Councilman Gerald Bottari

Councilman Paul Valentine

Councilman Thomas Diviny

Councilman Denis Troy

Supervisor Christopher Day

BID ITEM

Greenbush Road Bicycle Bypass

AUG 13 2018 SHEET

1 OF 2

TOWN OF ORANGETOWN

BID OPENING TIME

11:00AM

HIGHWAY DEPARTMENT

DATE

August 9, 2018

CONTRACTOR
NAME
&
ADDRESS

*Scallica Family
& Associates
W. Haverstraw NY*

DATE RECEIVED	8/8/18						
TIME RECEIVED	9:22pm						
NON COLLUSION STATEMENT	✓						
BID BOND or CERTIFIED CHECK	✓						

Item #1 - Estimated Quantity 229 CY / Unclassified Excavation and Disposal							
Unit Price	\$ 26.00	\$	\$	\$	\$	\$	
Computed Total	\$ 5954.00	\$	\$	\$	\$	\$	
Item #2 - Estimated Quantity 180 CY / Subbase Course N.Y.S.D.O.T. Item 304.14							
Unit Price	\$ 27.00	\$	\$	\$	\$	\$	
Computed Total	\$ 4860.00	\$	\$	\$	\$	\$	
Item #3 - Estimated Quantity 111 Tons / Hot Mix Asphalt Top Course, N.Y.S.D.O.T. Item No. 403.178902							
Unit Price	\$ 225.00	\$	\$	\$	\$	\$	
Computed Total	\$ 24975.00	\$	\$	\$	\$	\$	
Item #4 - Estimated Quantity 164 Tons / Hot Mix Asphalt Binder Course NYSOT, Item No. 402198901							
Unit Price	\$ 250.00	\$	\$	\$	\$	\$	
Computed Total	\$ 41000.00	\$	\$	\$	\$	\$	
Item #5 - Estimated Quantity 40 Gal / Tack Coat							
Unit Price	\$ 75.00	\$	\$	\$	\$	\$	
Computed Total	\$ 3000.00	\$	\$	\$	\$	\$	
Item #6 - Estimated Quantity 635 LF / Vinyl Coated Steel Chain-Link Fence on Plastic Coated Frame with Top Rail 6 Feet High							
Unit Price	\$ 90.00	\$	\$	\$	\$	\$	
Computed Total	\$ 57150.00	\$	\$	\$	\$	\$	
Item #7 - Estimated Quantity 30 LF / Smooth Interior Corrugated High Density Polyethylene Storm Drain 15 Inch Diameter							
Unit Price	\$ 25.00	\$	\$	\$	\$	\$	
Computed Total	\$ 750.00	\$	\$	\$	\$	\$	
Item #8 - Estimated Quantity 58 LF / Smooth Interior Corrugated High Density Polyethylene Storm Drain 18 Inch Diameter							
Unit Price	\$ 35.00	\$	\$	\$	\$	\$	
Computed Total	\$ 2030.00	\$	\$	\$	\$	\$	
Item #9 - Estimated Quantity 18 LF / Smooth Interior Corrugated High Density Polyethylene Storm Drain 24 Inch Diameter							
Unit Price	\$ 40.00	\$	\$	\$	\$	\$	
Computed Total	\$ 720.00	\$	\$	\$	\$	\$	
Item #10 - Estimated Quantity 1 LS / Maintenance of Site (Minimum \$2,000.00)							
Unit Price	\$ 4000.00	\$	\$	\$	\$	\$	
Computed Total	\$ 4000.00	\$	\$	\$	\$	\$	

BID OPENING TIME

11:00AM

DATE

August 9, 2018

CONTRACTOR
NAME
&
ADDRESS

DATE RECEIVED

TIME RECEIVED

NON COLLUSION
STATEMENT

BID BOND or
CERTIFIED CHECK

Item #11 -- Estimated Quantity 3 EA / Tree Removal (12" - 15")

Unit Price \$ 1500.00 \$ \$ \$ \$

Computed Total \$ 4500.00 \$ \$ \$ \$

Item #12 -- Estimated Quantity 163 CY / Fine Grading

Unit Price \$ 52.00 \$ \$ \$ \$

Computed Total \$ 8476.00 \$ \$ \$ \$

Item #13 -- Estimated Quantity 980 SY / Topsoil & Seeding

Unit Price \$ 6.00 \$ \$ \$ \$

Computed Total \$ 5880.00 \$ \$ \$ \$

Item #14 -- Estimated Quantity 1 LS / Surveying Operations

Unit Price \$ 6000.00 \$ \$ \$ \$

Computed Total \$ 6000.00 \$ \$ \$ \$

Item #15 -- Estimated Quantity 1 LS / Miscellaneous Additional Work (10,000 \$/LS)

Unit Price \$ 10000.00 \$ \$ \$ \$

Computed Total \$ 10000.00 \$ \$ \$ \$

SUMMATION \$ 171295.00 \$ \$ \$ \$

DIST:

NOTICE TO BIDDERS

SEALED BIDS WILL BE RECEIVED by the Town Board of the Town of Orangetown at the Town Clerk's Office, No. 26 Orangeburg Road, Orangeburg, New York until **10:30 A.M.** local time on **August 9, 2018** and will be publicly opened and read aloud at **11:00 A.M.** local time for GREENBUSH ROAD BICYCLE BYPASS, BLAUVELT, NEW YORK, in accordance with the Contract Documents on file with and which may be obtained at the Town Clerk's Office. Copies of the Contract Documents will be on file after **July 25, 2018**. A non-refundable fee of twenty-five (\$25.00) payable by check to the order of the Town of Orangetown will be required for each set of Contract Documents.

The work consists of the all labor, materials, supplies, and equipment necessary to install approximately 10 foot wide 880 linear foot bicycle path at Blauvelt State Park in the Hamlet of Blauvelt, N.Y.

The Contract Documents may be examined at the following locations:

*Town Clerk's Office, Town of Orangetown
26 Orangeburg Road, Orangeburg, NY 10962*

The Town Clerk and the Superintendent of Highways will submit a report to the Town Board of all bids received and their recommendations concerning the awarding of a contract at a meeting of the Town Board.

The Town Board of the Town of Orangetown reserves the right to waive any informalities in the bidding and to reject any and all bids.

The Town Board requires each bid to be accompanied by a certified check for a sum equal to five percent (5%) of the amount of the bid, or a bond with sufficient sureties to be approved by the Town Attorney, in a sum equal to five percent (5%) of the amount bid, conditioned that if his/her proposal is accepted, he/she will execute such further security as may be required for the faithful performance of the Contract as set forth in these contract documents.

The successful bidder will be required to post a Performance Bond in the amount of one hundred percent (100%) of the contract price.

No bid will be accepted without a Non-collusion Statement as required pursuant to Section 103d of the General Municipal Law.

Contractor warrants and represents that all employees and independent contractors affiliated with or employed by such contractors or any subcontractors shall be compensated at the prevailing wage, including, where applicable wage rates mandated by the New York State Department of Labor for the work performed in connection with any project.

It is understood that there must be a written contract executed by the Supervisor of the Town of Orangetown, pursuant to Town Board Resolution. This is subject to appropriations approved by the Town Board.

By order of the Town Board of the Town of Orangetown.

DATED: July 25, 2018

CHARLOTTE MADIGAN, TOWN CLERK

JAMES J. DEAN, SUPERINTENDENT OF HIGHWAYS

INFORMATION FOR BIDDERS

1. Definitions

Whenever the following words and expressions are used in these specifications, it is understood that they have the meanings given below:

Owner	Town of Orangetown as represented by its duly authorized representatives, also known as "Highway Department" and "Department of Environmental Management and Engineering."
Engineer	The term "Engineer" means the Superintendent of Highways, the Town of Orangetown's Department of Environmental Management and Engineering or its duly authorized representative.
Bidder	Any individual, firm or corporation submitting a proposal for the work C contemplated, acting directly or through a duly authorized representative.
Contractor	Party of the second part to the contract, acting directly or through his agents or employees. On the various bonds, the Contractor is also called the Principal.
Contract Documents	Means this contract and shall include the advertisement, the information for bidders, the Bid, the consent of surety, the forms of bonds, the contract, the specifications, the contract drawings, the addenda and the notice of award.
Work	The term "work" is used to designate the equipment, materials and things required to be done, furnished or performed by the Contractor under the Contract Documents attached hereto.
Bid or Proposal	The approved prepared form on which the bidder is to submit or has submitted a proposal for the work contemplated.
Surety	The corporate body which is bound with and for the Contractor and which engages to be responsible for his acceptable performance of the work for which he has contracted.
Performance Bond	The approved form of security furnished by Contractor and his surety as a guarantee of the completion of the project.
Bid Bond	The security to be furnished by the bidder as guarantee of his ability to procure the minimum equipment and liquid assets specified and that he will enter into a contract with the "Owner" for the performance of the work, if the work involved in the proposal is awarded to him.
Labor and Materials Payment Bond	The approved form of security furnished by the Contractor and his surety as a guarantee of the payment of all employees and material men.
Site	The area or areas which are the location(s) for the performance of the work.
Plans or Drawings	The contract and working drawings as specifically defined in the General Contract Conditions of this contract.

- Specifications The body of directions, requirements, etc., contained in this documents, together with all documents of any description and agreements made (or to be made), pertaining to the methods, (or manner) of performing the work, or the quantities and quality (as shown by test records) of accepted materials to be furnished under this contract. Specifications shall also include the Notice to Bidders, Proposal, Contract Agreement and Bond, and any Addenda issued.
- Contract The agreement covering the performance of the work and the furnishing of materials in the construction of the project. It shall include the Notice to Bidders, Instructions to Bidders, Proposal, Contract, General and Specific Contract Conditions and Bid Bonds, Plans or Drawings, Specifications, Addenda and any and all other writings necessary to complete the project.
- Material Any approved material acceptable to the Engineer and conforming to the requirements of the specifications. All processes and materials shall at all times be open to inspection and testing by the Engineer and his authorized representatives.
- Project thereto. The improvement set forth in the plans and specifications and all additions thereto.
- Completion The word 'completion' shall mean full and exact compliance and conformity with the provisions and requirements expressed or implied in the specifications and the plans, accompanying and forming a part of the same, including all amendments, revisions, corrections or additions, duly authorized.
- Sub-Contractor An individual, firm or corporation having a direct contract with the Contractor or with any other Sub-contractor for performance of a part of the work of this project.

2. Receipt and Opening of Bids

The Town of Orangetown, Rockland County, New York, herein called the "Owner", invites proposals on the forms attached hereto, all blanks on which must be filled in appropriately. Proposals shall be received by the Owner at Town Hall, No. 26 Orangeburg Road, Orangeburg, New York until 10:30 A.M. on **August 9, 2018** and will be publicly opened and read aloud at 11:00 A.M. The envelopes containing the proposals must be sealed, addressed to the Town Clerk, Town of Orangetown, No. 26 Orangeburg Road, Orangeburg, New York, and are to be designated as "Bids for GREENBUSH ROAD BICYCLE BYPASS, BLAUVELT, NEW YORK."

The Owner may consider informal any proposal not prepared and submitted in accordance with the provisions hereof and may waive any informalities in, or reject any and all proposals. Any proposal received after the time and date specified shall not be considered.

3. Preparation of Bid

Bids must be submitted on the prescribed form.

All bids must be submitted in sealed envelopes bearing on the outside the name of the bidder, his address, and the name of the project for which the proposal is submitted. (If forwarded by mail, the sealed envelope containing the proposal, and marked as directed above, must be enclosed in another envelope addressed as specified in the Bid Form, preferably by Certified

Mail.) If mailed, it is the Bidder's responsibility to insure that the bid is received prior to 10:30 A.M., August 9, 2018.

4. Modification of Bids

Any Bidder may modify his bid by written or telegraphic communication provided such communication is received by the Owner prior to the scheduled closing time for receipt of Bids. The communication should not reveal the bid price but should provide the addition or subtraction or other modification so that the final prices or terms will not be known by the Owner until the original bid is opened.

5. Withdrawal of Bids

A Bid may be withdrawn prior to the scheduled time for the opening of bids by written request or in person. No bid may be withdrawn after the time scheduled for bid opening unless the forty-five (45) days specified in the Article "AWARD OF CONTRACT" of these INSTRUCTIONS TO BIDDERS shall have elapsed.

6. Qualifications of Bidder

The Owner may make such investigations as he deems necessary to determine the ability of the bidder to perform the work, and the bidder shall furnish to the Owner all such information and data for this purpose as the Owner may request. The Owner reserves the right to reject any proposal if the evidence submitted by, or investigation of, such bidder fails to satisfy the Owner that such bidder is properly qualified to carry out the obligations of the contract and to complete the work contemplated herein. Conditional proposals will not be accepted.

7. Subcontractor

A. Bidders are advised that the lowest responsible bidder will be required, upon request of the Owner, and within three (3) days of such request to submit a list of subcontractors proposed for the performance of the work. Alternate subcontractors may be included in the list, provided that the use of such alternate subcontractors approved by the Owner shall not result in any change in the contract prices stated in the Proposal.

B. If requested by the Engineer, he shall also furnish a statement as to the subcontractor's experience, financial ability or other qualifications for properly performing the work proposed to be subcontracted. The Owner reserves the right to limit the total amounts of subcontracts to thirty-five (35) percent of the total contract price.

8. Debarments, Suspensions And Voluntary Exclusions

The award of contracts or subcontracts is specifically forbidden to any firm or individual listed on the USEPA Master List of debarments, suspensions and voluntary exclusions. The Contractor, if intending to award subcontracts should contact the Owner who will in turn ascertain from the NYSDEC whether any individual or firm under consideration is currently listed.

9. Award Of Contract

A. Within forty-five (45) days after the opening of Bids, unless otherwise stated in the INSTRUCTIONS TO BIDDERS or GENERAL CONTRACT CONDITIONS, award of the Contract will be made to the lowest, responsive, responsible Bidder.

In order to be considered responsive, a Bid must:

1. Conform in all respects to the conditions in the Invitation to Bid and these Instructions to Bidders;
2. Conform in all respects to the requirements in all Attachments contained in the Contract Documents;
- B. In order to be considered responsible, a Bidder must establish to the complete satisfaction of the Owner as a minimum that he has:
 1. Adequate financial resources to meet his Contract obligations and maintain them for the Contract period;
 2. Adequate equipment to perform the work properly and within the time prescribed in the Contract;
 3. The necessary experience and technical qualifications in the type of work provided for in the Contract.
- C. The Owner reserves the right to reject all Bids, or any bid not in compliance with the Contract Documents, and to waive any informalities in Bids received.

10. Bid Bond

Each bid shall be accompanied by a check or a bid bond executed by a surety company acceptable to the Owner in an amount not less than five percent (5%) of the amount bid, conditioned that if the bid is accepted, the Bidder will enter into a contract for the work and he will execute such further security as may be required for the faithful performance of the contract.

11. Liquidated Damages for Failure to Enter into Contract

The successful bidder, upon his failure or refusal to execute and deliver the contract and bond required within ten (10) days after he has received notice of the acceptance of his proposal, shall forfeit to the Owner, as liquidated damages for such failure or refusal, the security deposited with his proposal.

12. Pre-work Conference

Prior to commencing work on this project, the Owner shall call a conference to be attended by the Contractor and the Owner. A plan shall be initiated at this conference regarding the prosecution of the work and required action to comply with requirements of agencies having jurisdiction.

13. Condition of Work

Each bidder must inform himself fully of the conditions relating to the construction and labor under which the work will be performed. Failure to do so will not relieve a successful bidder of his obligation to furnish all material and labor necessary to carry out the provisions set forth in his proposal. Insofar as possible, the Contractor, in the carrying out of his work, must

employ such methods or means as will not cause any interruptions of or interference with the routine operations of Owner's facility and personnel.

Bidders are notified that it is obligatory upon them to obtain by their own means information which they may require as to existing physical conditions. Each bidder in bidding, represents that he relies exclusively upon his own investigations and he makes his bid with a full knowledge of all conditions, and the kind, quality, and quantity of work required.

14. Operations Maintained

It is essential to the public safety that inconvenience to local property owners be kept to a minimum.

If pavement restoration is not completed, the Contractor shall be responsible for prompt and efficient snow removal within the work area limits.

15. Site Inspection

At the time of the opening of proposals, each bidder will be presumed to have inspected the site of the proposed work, and to have read and to be thoroughly familiar with the Contract Documents (including all addenda). The failure or omission of any bidder to receive or examine any form, instrument or documents, shall in no way relieve any bidder from any obligation in respect to his proposal.

16. Addenda and Interpretations

No interpretation of the meaning of the specifications, or other Contract Documents will be made to any bidder orally. Every request for such interpretation should be in writing, addressed to Town of Orangetown, Highway Department, 119 Route 303, Orangeburg, New York, 10962 and to be given consideration must be received at least (5) five days prior to the date fixed for the opening of proposals.

Any and all such interpretations and any supplemental instructions will be in the form of written addenda to the Contract Documents, which if issued, will be mailed to all prospective bidders at the respective addresses furnished for such purposes not later than three (3) days prior to the date fixed for the opening of proposals. Failure of any bidder to receive any such addendum or interpretation shall not relieve any bidder from any obligation under his proposal submitted. All addenda so issued shall become part of the Contract Documents.

17. Security for Faithful Performance

Simultaneously with his delivery of the executed contract, the Contractor shall furnish a surety bond in an amount at least equal to one hundred percent (100%) of the contract price, as security for faithful performance of this contract and for the payment of all persons performing labor on the project under this contract and furnishing materials in connection with this contract, in such form as acceptable to the Town Attorney. The surety bond shall include a provision for maintenance as set forth in the agreement.

18. Power of Attorney

Attorneys-in-fact who sign bid bonds or contract bonds must file with each bond a certified copy of their power of attorney to sign said bids.

19. Laws and Regulations

The bidder's attention is directed to the fact that all applicable State, and Municipal Laws, and rules and regulations of all authorities having jurisdiction over construction work in the locality of the project shall apply to the contract throughout, and they are deemed to be included herein the same as though herein written out in full.

All contractors actually undertaking the work required shall save and hold harmless the Town of Orangetown from any and all costs, fees, disbursements, attorneys fees and damages (actual, consequential, or exemplary), awarded in any manner whatsoever through suit, settlement or otherwise, arising out of any claims, suit, action or dispute involving wages paid to all subcontractors, employees, independent contractors, or other persons employed by a contractor employed by the Town of Orangetown

This contract may not be assigned by the contractor or its right, title and interest therein assigned, transferred, conveyed, sublet or otherwise disposed of without the previous consent in writing of the Town of Orangetown and any attempts to assign the contract without the Town's written consent shall be deemed a breach thereof.

The Town shall have no liability under this contract to the contractor or anyone else beyond the funds appropriated and available for the contract. This contract shall be void and of no force and effect unless the contractor shall provide and maintain coverage during the life of this contract for the benefit of such employees as are required to be covered by the provisions of the Workers Compensation Law. Failure to do so shall constitute a breach of this contract.

The contractor must maintain complete and accurate books, records, documents, accounts and other evidence directly pertinent to the performance under this contract hereinafter collectively called the records. The records must be kept for the balance of the calendar year in which they were made and for six additional years thereafter.

In addition to the methods of service allowed by the New York State Civil Practice Law and Rules, the contractor consents to service of process upon it by certified mail, return receipt requested. Service hereunder shall be completed upon the contractor's actual receipt of process or upon the Town's receipt of the return thereof by the United States Postal Service as refused or undeliverable. The Contractor must promptly notify the Town in writing of each and every change of address to which service or process can be made. Service by the Town to the last known address shall be sufficient. The Contractor will have thirty calendar days after service hereunder as complete in which to respond.

20. Lowest Qualified Bidders and Award of Work

Only qualified bidders who have adequate experience, finances, equipment and personnel will be considered in making awards. An award will be made to the lowest qualified bidder, except that the Owner reserves the right to waive any informalities in and reject any and all proposals, or to make an award to other than the low bidder or to advertise for new proposals, if it be deemed to be in the best interests of the Town of Orangetown to do so.

21. Time for Completion

The attention of the bidder is directed to the General Contract Conditions and to Article 33 entitled "Time of Commencement and Completion", bound with and forming part of the Contract Documents.

BID

FOR: GREENBUSH ROAD BICYCLE BYPASS
BLAUVELT, NEW YORK

TO: TOWN BOARD, TOWN OF ORANGETOWN, NEW YORK

FROM: Scaffidi's Paving And Drainage

34 North Route 9W

West Haverstraw, NY 10993

Pursuant to and in accordance with your sealed bids dated **August 9, 2018** and the Contract Documents relating thereto, the undersigned hereby offers to furnish all things necessary or proper for, and incidental to, the construction of the work for which he is submitting a proposal as described above, complete, in place, tested and ready for use, together with all appurtenances and appurtenant work, for the price set forth in the following schedule required by, and in strict accordance with the Specifications, and other Contract Documents thereof, including all addenda issued by the Owner and mailed to the undersigned prior to the opening of bids, whether received by the undersigned or not.

The bidder further declares that he will provide all necessary machinery, tools, materials, labor and other necessary means of construction to do all work called for by the Specifications in full compliance with the decisions and requirements of the Engineer or the Superintendent of Highways of the Town of Orangetown.

The bidder agrees to said work according to these Specifications for the following prices:

<u>Item No.</u>	<u>Estimated Quantity</u>	<u>Description</u>	<u>Unit Price (numbers) Unit Price (words)</u>	<u>Computed Total</u>
1	229 CY	Unclassified Excavation And Disposal	<u>26.00</u> \$/CY <u>TWENTY SIX DOLLARS</u> \$/CY	<u>\$ 5,954.00</u>
2	180 CY	Subbase Course, N.Y.S.D.O.T. Item 304.14	<u>27.00</u> \$/CY <u>TWENTY SEVEN DOLLARS</u> \$/CY	<u>\$ 4,860.00</u>
3	111 TONS	Hot Mix Asphalt Top Course, NYSDOT Item No. 403.178902	<u>200.00</u> \$/TONS <u>TWO HUNDRED DOLLARS</u> \$/TONS	<u>\$ 22,200.00</u>

<u>Item No.</u>	<u>Estimated Quantity</u>	<u>Description</u>	<u>Unit Price (numbers)</u> <u>Unit Price (words)</u>	<u>Computed Total</u>
4	164 TONS	Hot Mix Asphalt Binder Course, N.Y.S.D.O.T. Item No. 402.198901	<u>200.00</u> \$/TONS <u>TWO HUNDRED DOLLARS</u> \$/TONS	<u>\$ 32,800.00</u>
5	40 GAL	Tack Coat	<u>75.00</u> \$/GAL <u>SEVENTY-FIVE DOLLARS</u> \$/GAL	<u>\$ 3,000.00</u>
6	635 LF	Vinyl Coated Steel Chain-Link Fence on Plastic Coated Frame With Top Rail 6 Feet High	<u>78.00</u> \$/LF <u>SEVENTY-EIGHT DOLLARS</u> \$/LF	<u>\$ 49,530.00</u>
7	30 LF	Smooth Interior Corrugated High Density Polyethylene Storm Drain 15 Inch Diameter	<u>25.00</u> \$/LF <u>TWENTY-FIVE DOLLARS</u> \$/LF	<u>\$ 750.00</u>
8	58 LF	Smooth Interior Corrugated High Density Polyethylene Storm Drain 18 Inch Diameter	<u>35.00</u> \$/LF <u>THIRTY-FIVE DOLLARS</u> \$/LF	<u>\$ 2,030.00</u>
9	18 LF	Smooth Interior Corrugated High Density Polyethylene Storm Drain 24 Inch Diameter	<u>40.00</u> \$/LF <u>FORTY DOLLARS</u> \$/LF	<u>\$ 720.00</u>
10	1 LS	Maintenance of Site (Minimum \$2,000.00)	<u>3,000.00</u> \$/LS <u>THREE THOUSAND DOLLARS</u> \$/LS	<u>\$ 3,000.00</u>
11	3 EA	Tree Removal (12"-15")	<u>1,500.00</u> \$/EA <u>ONE THOUSAND, FIVE HUNDRED DOLLARS</u> \$/EA	<u>\$ 4,500.00</u>
12	163 CY	Fine Grading	<u>48.00</u> \$/CY <u>FORTY-EIGHT DOLLARS</u> \$/CY	<u>\$ 7,824.00</u>

<u>Item No.</u>	<u>Estimated Quantity</u>	<u>Description</u>	<u>Unit Price (numbers)</u> <u>Unit Price (words)</u>	<u>Computed Total</u>
13	980 SY	Topsoil & Seeding	6.00 \$/SY SIX DOLLARS \$/SY	\$ 5,880.00
14	1 LS	Surveying Operations	5,000.00 \$/LS FIVE THOUSAND DOLLARS \$/LS	\$ 5,000.00
15	1 LS	Miscellaneous Additional Work	10,000 \$/LS Ten Thousand \$/LS	\$ 10,000.00
Summation \$				158,048.00

BY: Danny Scaffidi

TITLE: Vice President

COMPANY OR CORPORATION: Scaffidi's Paving And Drainage

34 North Route 9W

West Haverstraw, NY 10993

Email: Anthony@ScaffidisPaving.com

TELEPHONE NUMBER: (845) 429-0081

The "summation" is based on the approximate estimates of quantities given above and the prices bid for the various items. This statement is made with the understanding that the "summation" is not a part of the bid and is solely a matter of information for convenience in comparing bids at the time of opening.

It is understood that the Town of Orangetown will pay for only that part of the work that is constructed. The Town may increase or decrease the estimated quantities. The Contractor's unit prices shall be firm regardless of quantity. Further, the Town reserves the right to delete a payment item in its entirety.

NON-COLLUSION STATEMENT

STATEMENT ATTACHED TO AND FORMING PART OF ALL BIDS RECEIVED BY THE TOWN OF ORANGETOWN

(a) By submission of this bid, each bidder and each person signing on behalf of any bidder certifies, and in the case of a joint bid each party thereto certifies as to its own organization, under penalty of perjury, that to the best of knowledge and belief:

(1) The prices in this bid have been arrived at independently without collusion, consultation, communication, or agreement, for the purpose of restricting competition, as to any matter relating to such prices with any other bidder or with any competitor;

(2) Unless otherwise required by law, the prices which have been quoted in this bid have not been knowingly disclosed by the bidder and will not knowingly be disclosed by the bidder prior to opening, directly or indirectly, to any other bidder or to any competitor; and,

(3) No attempt has been made or will be made by the bidder to induce any other person, partnership or corporation to submit or not to submit a bid for the purpose of restricting competition.

(b) A bid shall not be considered for award nor shall any award be made where (a), (1), (2) and (3) above have not been complied with; provided, however, that if in any case the bidder cannot make the foregoing certification, the bidder shall so state and shall furnish with the bid a signed statement which sets forth in details the reasons therefor. Where (a), (1), (2) and (3) above have not been complied with, the bid shall not be considered for award nor shall any award be made unless the head of the purchasing unit of the political subdivision, public department, agency or official thereof to which the bid is made, or his designee, determines that such disclosure was not made for the purpose of restricting competition.

The fact that a bidder (a) has published price lists, rates or tariffs covering items being procured, (b) has informed prospective customers of proposed or pending publication of new or revised price lists for such items, or (c) has sold the same items to other customers at the same price being bid, does not constitute, without more, a disclosure within the meaning of subparagraph one (a).

(c) Any bid hereafter made to any political subdivision of the State or any public department, agency, or official thereof by a corporate bidder for work or service performed or to be performed or goods sold or to be sold, where competitive bidding is required by statute, rule, regulation, or local law, and where such bid contains the certification referred to in subdivision one of this section, shall be deemed to have been authorized by the board of directors of the bidder, and such authorization shall be deemed to include the signing and submission of the bid and the inclusion therein of the certificate as to non-collusion as the act and deed of the corporation.

This statement is subscribed by bidder or person signing on behalf of bidder and affirmed as true under penalties of perjury.

DATED: August 2nd, 2018

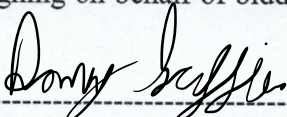
BY: 
Danny Scaffidi - Vice President

FOR: Town of Orangetown