

CONSTRUCTION SPECIFICATIONS

1. STONE SIZE - USE 2" STONE OR REMAINS OF RECYCLED CONCRETE EQUIVALENT. MAX 90% PASS #10 & 100% PASS #20.
2. REINFORCING BARS - USE #4 REBAR MINIMUM LENGTH 18" MINIMUM.
3. THICKNESS - NOT LESS THAN (8) INCHES.
4. MINIMUM 1" THICKNESS (12) INCHES MINIMUM FOR 2" THICKNESS.
5. FILTER FABRIC - MUST BE PLACED OVER THE ENTIRE AREA FROM THE EXISTING GROUND TO THE NEW CONSTRUCTION.
6. SURFACE WATER - ALL SURFACE WATER FLOWING OR DROPPED FROM CONSTRUCTION ENTRANCES SHALL BE COLLECTED IN THE 5" DEPTH DRAINAGE DITCHES AND MUST BE CONVEYED TO THE STREET OR TO AN APPROPRIATE DRAINAGE SYSTEM.
7. MAINTENANCE - THE ENTRANCE SHALL BE MAINTAINED IN A CLEAN AND SAFE CONDITION. ALL SEDIMENT SHALL BE REMOVED IMMEDIATELY.
8. WHEN WORKING IS REQUIRED, IT SHALL BE DONE ON AN AREA STABILIZED WITH SEEDING AND MULCH.
9. PROTECT EXISTING AND NEIGHBORING AREAS WHICH SHALL BE PROVIDED AFTER EACH DAY.

STABILIZED CONSTRUCTION ENTRANCE

PLAN VIEW

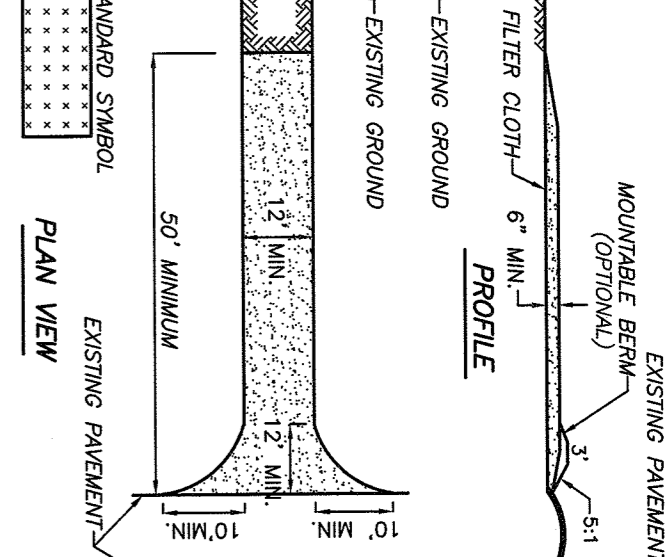

PROFILE

CONSTRUCTION NOTES FOR FABRICATED SILT FENCE

1. WIRE FENCE TO BE FASTENED TO POSTS WITH WIRE.
2. WIRE FENCE TO BE FASTENED TO POSTS WITH WIRE.
3. WIRE FENCE TO BE FASTENED TO POSTS WITH WIRE.
4. WIRE FENCE TO BE FASTENED TO POSTS WITH WIRE.
5. WIRE FENCE TO BE FASTENED TO POSTS WITH WIRE.
6. WIRE FENCE TO BE FASTENED TO POSTS WITH WIRE.
7. WIRE FENCE TO BE FASTENED TO POSTS WITH WIRE.
8. WIRE FENCE TO BE FASTENED TO POSTS WITH WIRE.
9. WIRE FENCE TO BE FASTENED TO POSTS WITH WIRE.
10. WIRE FENCE TO BE FASTENED TO POSTS WITH WIRE.
11. WIRE FENCE TO BE FASTENED TO POSTS WITH WIRE.
12. WIRE FENCE TO BE FASTENED TO POSTS WITH WIRE.
13. WIRE FENCE TO BE FASTENED TO POSTS WITH WIRE.
14. WIRE FENCE TO BE FASTENED TO POSTS WITH WIRE.
15. WIRE FENCE TO BE FASTENED TO POSTS WITH WIRE.
16. WIRE FENCE TO BE FASTENED TO POSTS WITH WIRE.
17. WIRE FENCE TO BE FASTENED TO POSTS WITH WIRE.
18. WIRE FENCE TO BE FASTENED TO POSTS WITH WIRE.
19. WIRE FENCE TO BE FASTENED TO POSTS WITH WIRE.
20. WIRE FENCE TO BE FASTENED TO POSTS WITH WIRE.

WIRE REINFORCED SILT FENCE

SECTION

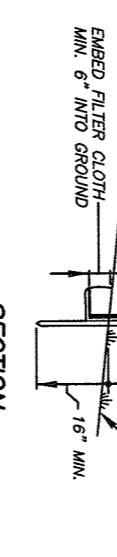

CONSTRUCTION NOTES FOR FABRICATED SILT FENCE

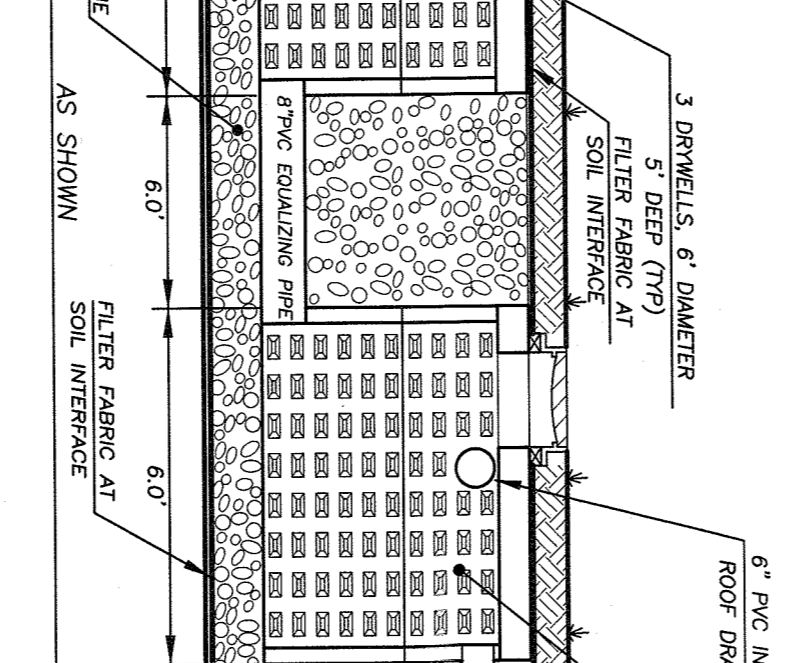
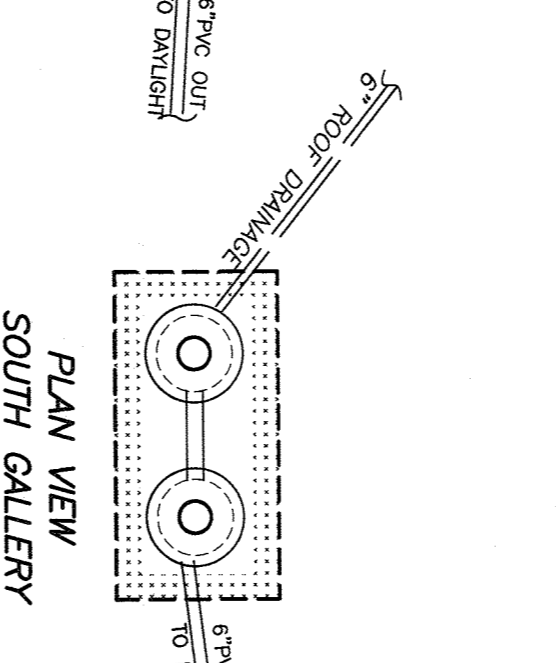
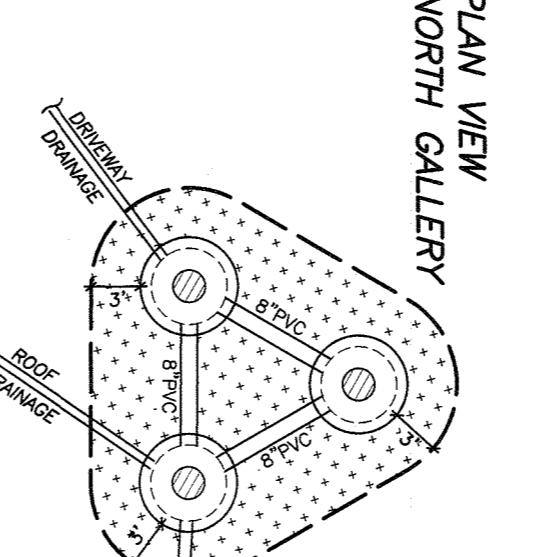
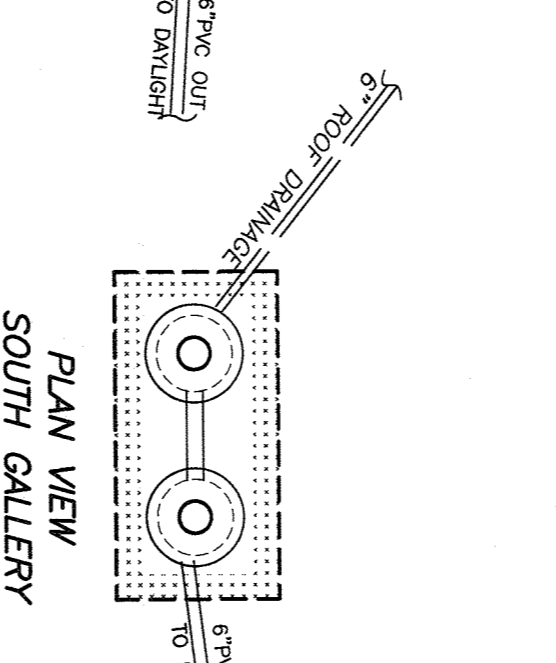

6" PRECAST DRYWELLS IN STONE SURROUND

(FOR NORTH GALLERY, THIRD DRYWELL IS NOT VISIBLE IN THIS PERSPECTIVE)

