

Copyright Reserved
No part of this drawing may be reproduced, stored in a retrieval system, or transmitted in any form or by any means, electronic, mechanical, photocopying, recording, or by any information storage and retrieval system, without the prior written permission of Stantec. All rights reserved.

Constraints

Legend

Notes

NO.	REVISION	DATE
1	ISSUED FOR PERMITS	02/11/2021
2	REVISED PER TOWN COMMENTS	02/11/2021
3	REVISED PER TOWN COMMENTS	02/11/2021
4	REVISED PER TOWN COMMENTS	02/11/2021
5	REVISED PER TOWN COMMENTS	02/11/2021
6	REVISED PER TOWN COMMENTS	02/11/2021
7	REVISED PER TOWN COMMENTS	02/11/2021
8	REVISED PER TOWN COMMENTS	02/11/2021
9	REVISED PER TOWN COMMENTS	02/11/2021
10	REVISED PER TOWN COMMENTS	02/11/2021
11	REVISED PER TOWN COMMENTS	02/11/2021
12	REVISED PER TOWN COMMENTS	02/11/2021
13	REVISED PER TOWN COMMENTS	02/11/2021
14	REVISED PER TOWN COMMENTS	02/11/2021
15	REVISED PER TOWN COMMENTS	02/11/2021
16	REVISED PER TOWN COMMENTS	02/11/2021
17	REVISED PER TOWN COMMENTS	02/11/2021
18	REVISED PER TOWN COMMENTS	02/11/2021
19	REVISED PER TOWN COMMENTS	02/11/2021
20	REVISED PER TOWN COMMENTS	02/11/2021
21	REVISED PER TOWN COMMENTS	02/11/2021
22	REVISED PER TOWN COMMENTS	02/11/2021
23	REVISED PER TOWN COMMENTS	02/11/2021
24	REVISED PER TOWN COMMENTS	02/11/2021
25	REVISED PER TOWN COMMENTS	02/11/2021
26	REVISED PER TOWN COMMENTS	02/11/2021
27	REVISED PER TOWN COMMENTS	02/11/2021
28	REVISED PER TOWN COMMENTS	02/11/2021
29	REVISED PER TOWN COMMENTS	02/11/2021
30	REVISED PER TOWN COMMENTS	02/11/2021
31	REVISED PER TOWN COMMENTS	02/11/2021
32	REVISED PER TOWN COMMENTS	02/11/2021
33	REVISED PER TOWN COMMENTS	02/11/2021
34	REVISED PER TOWN COMMENTS	02/11/2021
35	REVISED PER TOWN COMMENTS	02/11/2021
36	REVISED PER TOWN COMMENTS	02/11/2021
37	REVISED PER TOWN COMMENTS	02/11/2021
38	REVISED PER TOWN COMMENTS	02/11/2021
39	REVISED PER TOWN COMMENTS	02/11/2021
40	REVISED PER TOWN COMMENTS	02/11/2021
41	REVISED PER TOWN COMMENTS	02/11/2021
42	REVISED PER TOWN COMMENTS	02/11/2021
43	REVISED PER TOWN COMMENTS	02/11/2021
44	REVISED PER TOWN COMMENTS	02/11/2021
45	REVISED PER TOWN COMMENTS	02/11/2021
46	REVISED PER TOWN COMMENTS	02/11/2021
47	REVISED PER TOWN COMMENTS	02/11/2021
48	REVISED PER TOWN COMMENTS	02/11/2021
49	REVISED PER TOWN COMMENTS	02/11/2021
50	REVISED PER TOWN COMMENTS	02/11/2021
51	REVISED PER TOWN COMMENTS	02/11/2021
52	REVISED PER TOWN COMMENTS	02/11/2021
53	REVISED PER TOWN COMMENTS	02/11/2021
54	REVISED PER TOWN COMMENTS	02/11/2021
55	REVISED PER TOWN COMMENTS	02/11/2021
56	REVISED PER TOWN COMMENTS	02/11/2021
57	REVISED PER TOWN COMMENTS	02/11/2021
58	REVISED PER TOWN COMMENTS	02/11/2021
59	REVISED PER TOWN COMMENTS	02/11/2021
60	REVISED PER TOWN COMMENTS	02/11/2021
61	REVISED PER TOWN COMMENTS	02/11/2021
62	REVISED PER TOWN COMMENTS	02/11/2021
63	REVISED PER TOWN COMMENTS	02/11/2021
64	REVISED PER TOWN COMMENTS	02/11/2021
65	REVISED PER TOWN COMMENTS	02/11/2021
66	REVISED PER TOWN COMMENTS	02/11/2021
67	REVISED PER TOWN COMMENTS	02/11/2021
68	REVISED PER TOWN COMMENTS	02/11/2021
69	REVISED PER TOWN COMMENTS	02/11/2021
70	REVISED PER TOWN COMMENTS	02/11/2021
71	REVISED PER TOWN COMMENTS	02/11/2021
72	REVISED PER TOWN COMMENTS	02/11/2021
73	REVISED PER TOWN COMMENTS	02/11/2021
74	REVISED PER TOWN COMMENTS	02/11/2021
75	REVISED PER TOWN COMMENTS	02/11/2021
76	REVISED PER TOWN COMMENTS	02/11/2021
77	REVISED PER TOWN COMMENTS	02/11/2021
78	REVISED PER TOWN COMMENTS	02/11/2021
79	REVISED PER TOWN COMMENTS	02/11/2021
80	REVISED PER TOWN COMMENTS	02/11/2021
81	REVISED PER TOWN COMMENTS	02/11/2021
82	REVISED PER TOWN COMMENTS	02/11/2021
83	REVISED PER TOWN COMMENTS	02/11/2021
84	REVISED PER TOWN COMMENTS	02/11/2021
85	REVISED PER TOWN COMMENTS	02/11/2021
86	REVISED PER TOWN COMMENTS	02/11/2021
87	REVISED PER TOWN COMMENTS	02/11/2021
88	REVISED PER TOWN COMMENTS	02/11/2021
89	REVISED PER TOWN COMMENTS	02/11/2021
90	REVISED PER TOWN COMMENTS	02/11/2021
91	REVISED PER TOWN COMMENTS	02/11/2021
92	REVISED PER TOWN COMMENTS	02/11/2021
93	REVISED PER TOWN COMMENTS	02/11/2021
94	REVISED PER TOWN COMMENTS	02/11/2021
95	REVISED PER TOWN COMMENTS	02/11/2021
96	REVISED PER TOWN COMMENTS	02/11/2021
97	REVISED PER TOWN COMMENTS	02/11/2021
98	REVISED PER TOWN COMMENTS	02/11/2021
99	REVISED PER TOWN COMMENTS	02/11/2021
100	REVISED PER TOWN COMMENTS	02/11/2021

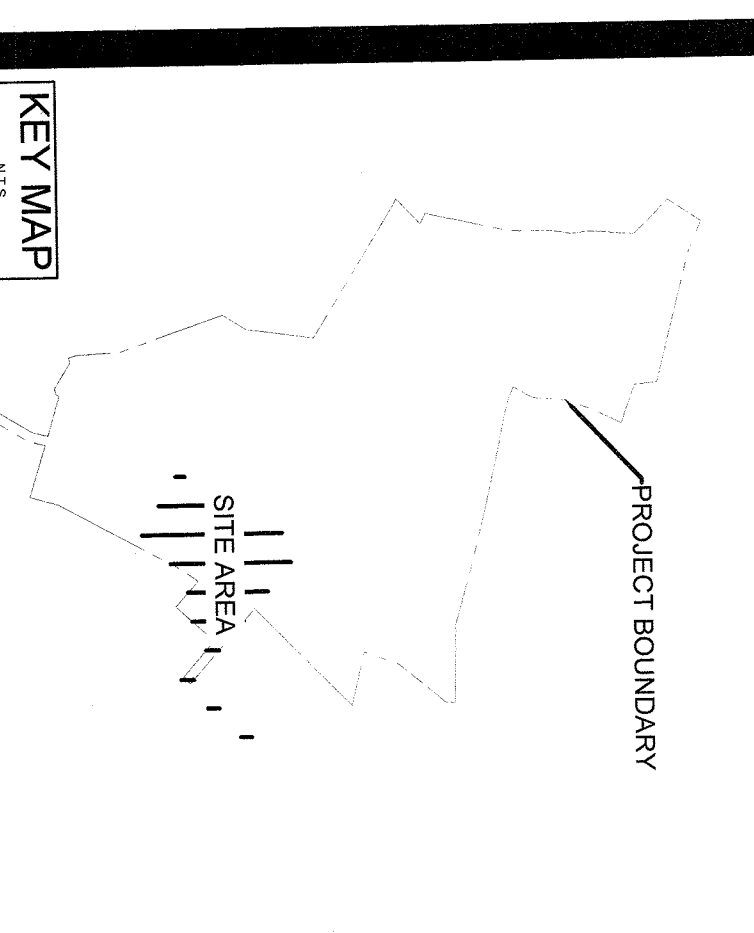

Client/Project
UJA FEDERATION OF NEW YORK
UJA Real River Day Camp
Proposed Improvements
Oongtstown, New York

STORMWATER UTILITY PROFILES
SW MANAGEMENT IMPROVEMENTS
Project No. 1951.1955
Scale 1"=20'
Drawing No. Sheet 7 of 12
Revision 6
Permit Seal

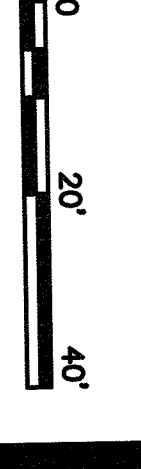
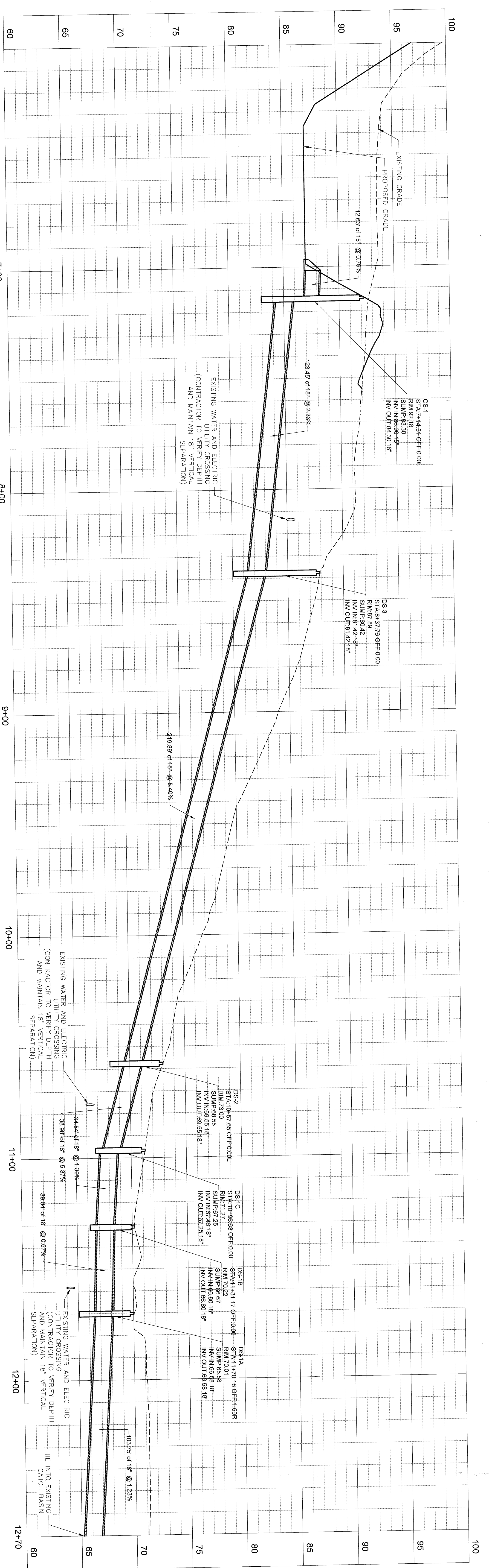
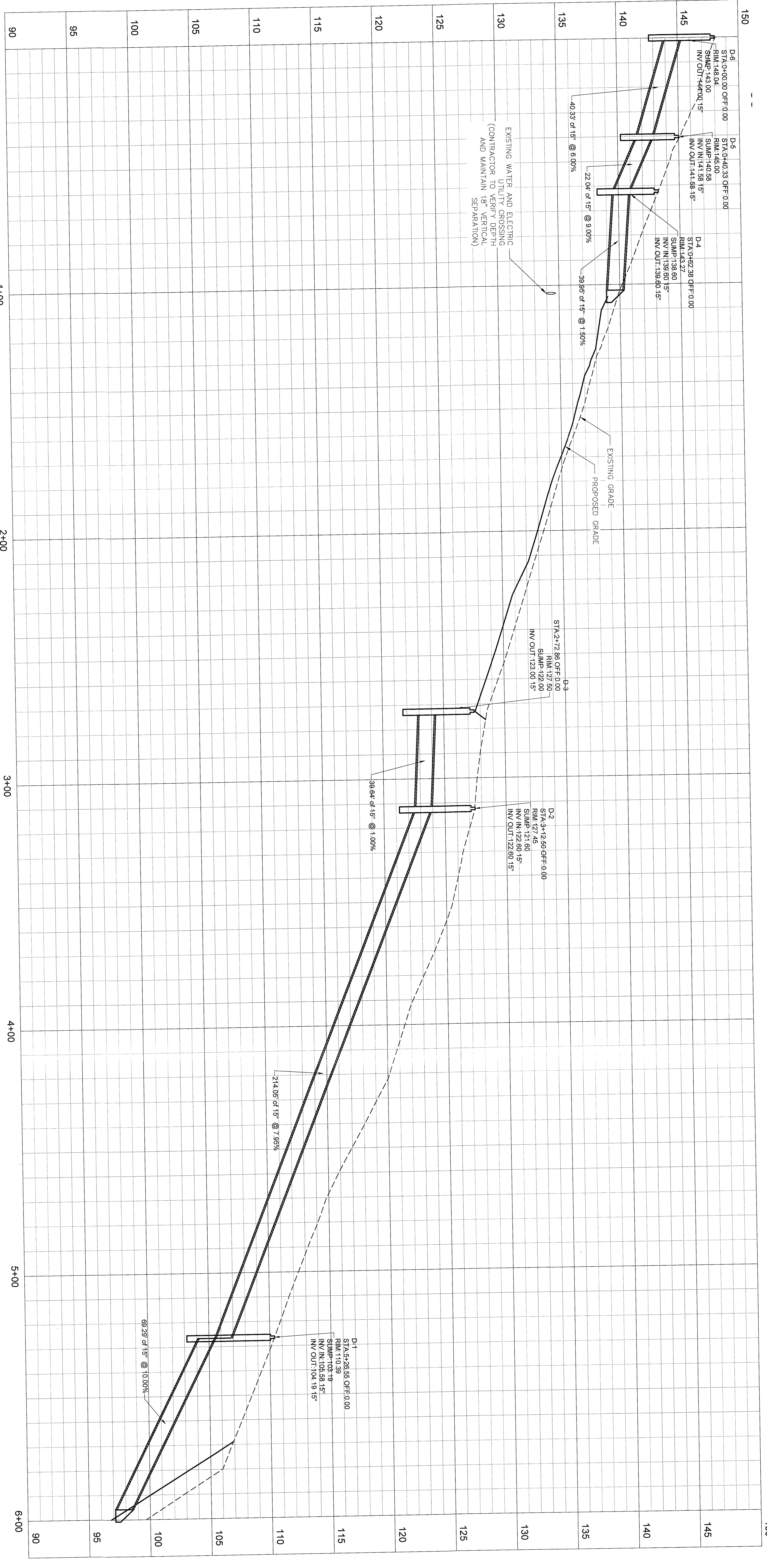

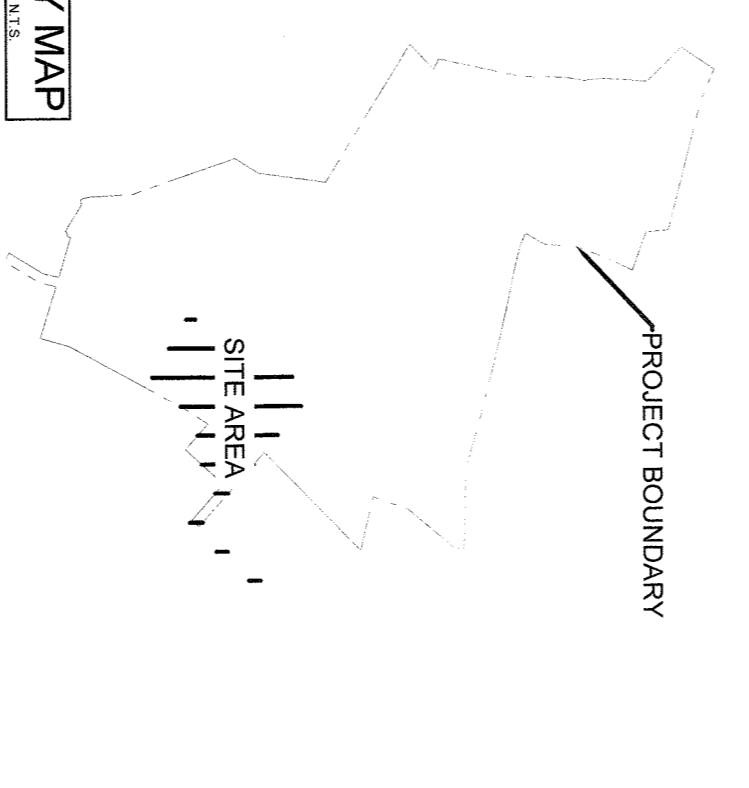
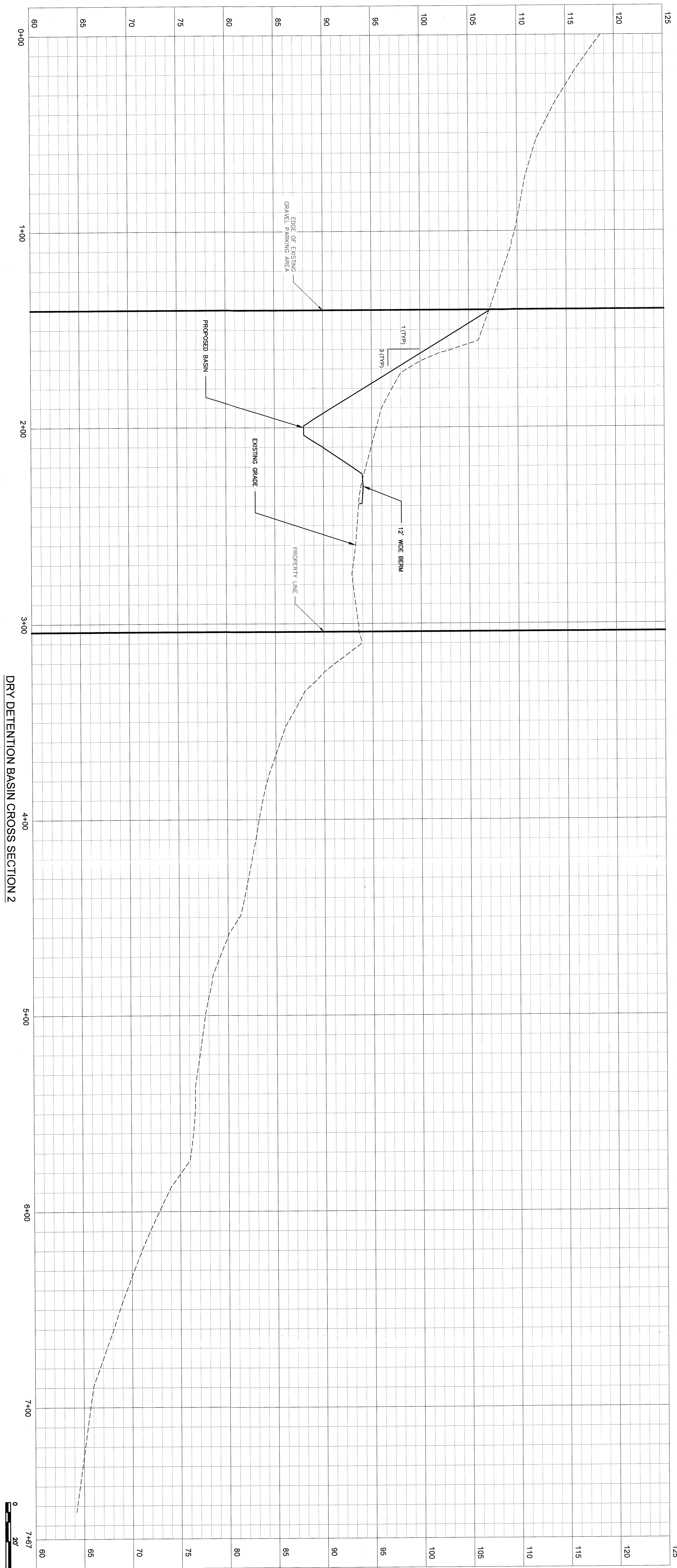
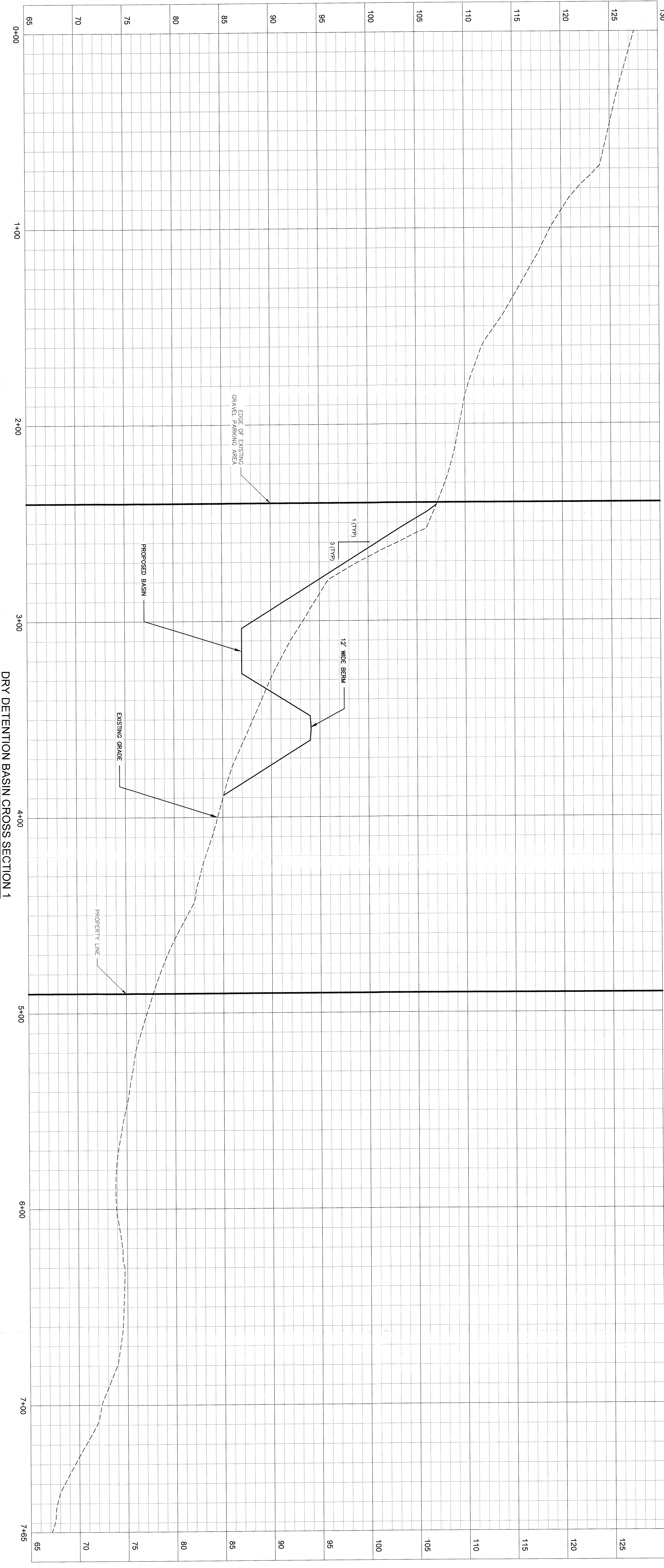

KEY MAP

1. DESIGN THE TYPICAL CHANNEL	DATE	1/11/11
2. REVIEW THE TYPICAL CHANNELS	DATE	2/01/12
3. REVISED THE TYPICAL CHANNELS	DATE	2/04/12
4. REVIEW THE TYPICAL CHANNELS	DATE	3/11/12
5. REVIEW THE TYPICAL CHANNELS	DATE	3/11/12
6. REVIEW THE TYPICAL CHANNELS	DATE	3/11/12
7. REVIEW THE TYPICAL CHANNELS	DATE	3/11/12
8. REVIEW THE TYPICAL CHANNELS	DATE	3/11/12
9. REVIEW THE TYPICAL CHANNELS	DATE	3/11/12
10. REVIEW THE TYPICAL CHANNELS	DATE	3/11/12
11. REVIEW THE TYPICAL CHANNELS	DATE	3/11/12
12. REVIEW THE TYPICAL CHANNELS	DATE	3/11/12
13. REVIEW THE TYPICAL CHANNELS	DATE	3/11/12
14. REVIEW THE TYPICAL CHANNELS	DATE	3/11/12
15. REVIEW THE TYPICAL CHANNELS	DATE	3/11/12
16. REVIEW THE TYPICAL CHANNELS	DATE	3/11/12
17. REVIEW THE TYPICAL CHANNELS	DATE	3/11/12
18. REVIEW THE TYPICAL CHANNELS	DATE	3/11/12
19. REVIEW THE TYPICAL CHANNELS	DATE	3/11/12
20. REVIEW THE TYPICAL CHANNELS	DATE	3/11/12
21. REVIEW THE TYPICAL CHANNELS	DATE	3/11/12
22. REVIEW THE TYPICAL CHANNELS	DATE	3/11/12
23. REVIEW THE TYPICAL CHANNELS	DATE	3/11/12
24. REVIEW THE TYPICAL CHANNELS	DATE	3/11/12
25. REVIEW THE TYPICAL CHANNELS	DATE	3/11/12
26. REVIEW THE TYPICAL CHANNELS	DATE	3/11/12
27. REVIEW THE TYPICAL CHANNELS	DATE	3/11/12
28. REVIEW THE TYPICAL CHANNELS	DATE	3/11/12
29. REVIEW THE TYPICAL CHANNELS	DATE	3/11/12
30. REVIEW THE TYPICAL CHANNELS	DATE	3/11/12
31. REVIEW THE TYPICAL CHANNELS	DATE	3/11/12
32. REVIEW THE TYPICAL CHANNELS	DATE	3/11/12
33. REVIEW THE TYPICAL CHANNELS	DATE	3/11/12
34. REVIEW THE TYPICAL CHANNELS	DATE	3/11/12
35. REVIEW THE TYPICAL CHANNELS	DATE	3/11/12
36. REVIEW THE TYPICAL CHANNELS	DATE	3/11/12
37. REVIEW THE TYPICAL CHANNELS	DATE	3/11/12
38. REVIEW THE TYPICAL CHANNELS	DATE	3/11/12
39. REVIEW THE TYPICAL CHANNELS	DATE	3/11/12
40. REVIEW THE TYPICAL CHANNELS	DATE	3/11/12
41. REVIEW THE TYPICAL CHANNELS	DATE	3/11/12
42. REVIEW THE TYPICAL CHANNELS	DATE	3/11/12
43. REVIEW THE TYPICAL CHANNELS	DATE	3/11/12
44. REVIEW THE TYPICAL CHANNELS	DATE	3/11/12
45. REVIEW THE TYPICAL CHANNELS	DATE	3/11/12
46. REVIEW THE TYPICAL CHANNELS	DATE	3/11/12
47. REVIEW THE TYPICAL CHANNELS	DATE	3/11/12
48. REVIEW THE TYPICAL CHANNELS	DATE	3/11/12
49. REVIEW THE TYPICAL CHANNELS	DATE	3/11/12
50. REVIEW THE TYPICAL CHANNELS	DATE	3/11/12
51. REVIEW THE TYPICAL CHANNELS	DATE	3/11/12
52. REVIEW THE TYPICAL CHANNELS	DATE	3/11/12
53. REVIEW THE TYPICAL CHANNELS	DATE	3/11/12
54. REVIEW THE TYPICAL CHANNELS	DATE	3/11/12
55. REVIEW THE TYPICAL CHANNELS	DATE	3/11/12
56. REVIEW THE TYPICAL CHANNELS	DATE	3/11/12
57. REVIEW THE TYPICAL CHANNELS	DATE	3/11/12
58. REVIEW THE TYPICAL CHANNELS	DATE	3/11/12
59. REVIEW THE TYPICAL CHANNELS	DATE	3/11/12
60. REVIEW THE TYPICAL CHANNELS	DATE	3/11/12
61. REVIEW THE TYPICAL CHANNELS	DATE	3/11/12
62. REVIEW THE TYPICAL CHANNELS	DATE	3/11/12
63. REVIEW THE TYPICAL CHANNELS	DATE	3/11/12
64. REVIEW THE TYPICAL CHANNELS	DATE	3/11/12
65. REVIEW THE TYPICAL CHANNELS	DATE	3/11/12
66. REVIEW THE TYPICAL CHANNELS	DATE	3/11/12
67. REVIEW THE TYPICAL CHANNELS	DATE	3/11/12
68. REVIEW THE TYPICAL CHANNELS	DATE	3/11/12
69. REVIEW THE TYPICAL CHANNELS	DATE	3/11/12
70. REVIEW THE TYPICAL CHANNELS	DATE	3/11/12
71. REVIEW THE TYPICAL CHANNELS	DATE	3/11/12
72. REVIEW THE TYPICAL CHANNELS	DATE	3/11/12
73. REVIEW THE TYPICAL CHANNELS	DATE	3/11/12
74. REVIEW THE TYPICAL CHANNELS	DATE	3/11/12
75. REVIEW THE TYPICAL CHANNELS	DATE	3/11/12
76. REVIEW THE TYPICAL CHANNELS	DATE	3/11/12
77. REVIEW THE TYPICAL CHANNELS	DATE	3/11/12
78. REVIEW THE TYPICAL CHANNELS	DATE	3/11/12
79. REVIEW THE TYPICAL CHANNELS	DATE	3/11/12
80. REVIEW THE TYPICAL CHANNELS	DATE	3/11/12
81. REVIEW THE TYPICAL CHANNELS	DATE	3/11/12
82. REVIEW THE TYPICAL CHANNELS	DATE	3/11/12
83. REVIEW THE TYPICAL CHANNELS	DATE	3/11/12
84. REVIEW THE TYPICAL CHANNELS	DATE	3/11/12
85. REVIEW THE TYPICAL CHANNELS	DATE	3/11/12
86. REVIEW THE TYPICAL CHANNELS	DATE	3/11/12
87. REVIEW THE TYPICAL CHANNELS	DATE	3/11/12
88. REVIEW THE TYPICAL CHANNELS	DATE	3/11/12
89. REVIEW THE TYPICAL CHANNELS	DATE	3/11/12
90. REVIEW THE TYPICAL CHANNELS	DATE	3/11/12
91. REVIEW THE TYPICAL CHANNELS	DATE	3/11/12
92. REVIEW THE TYPICAL CHANNELS	DATE	3/11/12
93. REVIEW THE TYPICAL CHANNELS	DATE	3/11/12
94. REVIEW THE TYPICAL CHANNELS	DATE	3/11/12
95. REVIEW THE TYPICAL CHANNELS	DATE	3/11/12
96. REVIEW THE TYPICAL CHANNELS	DATE	3/11/12
97. REVIEW THE TYPICAL CHANNELS	DATE	3/11/12
98. REVIEW THE TYPICAL CHANNELS	DATE	3/11/12
99. REVIEW THE TYPICAL CHANNELS	DATE	3/11/12
100. REVIEW THE TYPICAL CHANNELS	DATE	3/11/12
101. REVIEW THE TYPICAL CHANNELS	DATE	3/11/12
102. REVIEW THE TYPICAL CHANNELS	DATE	3/11/12
103. REVIEW THE TYPICAL CHANNELS	DATE	3/11/12
104. REVIEW THE TYPICAL CHANNELS	DATE	3/11/12
105. REVIEW THE TYPICAL CHANNELS	DATE	3/11/12
106. REVIEW THE TYPICAL CHANNELS	DATE	3/11/12
107. REVIEW THE TYPICAL CHANNELS	DATE	3/11/12
108. REVIEW THE TYPICAL CHANNELS	DATE	3/11/12
109. REVIEW THE TYPICAL CHANNELS	DATE	3/11/12
110. REVIEW THE TYPICAL CHANNELS	DATE	3/11/12
111. REVIEW THE TYPICAL CHANNELS	DATE	3/11/12
112. REVIEW THE TYPICAL CHANNELS	DATE	3/11/12
113. REVIEW THE TYPICAL CHANNELS	DATE	3/11/12
114. REVIEW THE TYPICAL CHANNELS	DATE	3/11/12
115. REVIEW THE TYPICAL CHANNELS	DATE	3/11/12
116. REVIEW THE TYPICAL CHANNELS	DATE	3/11/12
117. REVIEW THE TYPICAL CHANNELS	DATE	3/11/12
118. REVIEW THE TYPICAL CHANNELS	DATE	3/11/12
119. REVIEW THE TYPICAL CHANNELS	DATE	3/11/12
120. REVIEW THE TYPICAL CHANNELS	DATE	3/11/12
121. REVIEW THE TYPICAL CHANNELS	DATE	3/11/12
122. REVIEW THE TYPICAL CHANNELS	DATE	3/11/12
123. REVIEW THE TYPICAL CHANNELS	DATE	3/11/12
124. REVIEW THE TYPICAL CHANNELS	DATE	3/11/12
125. REVIEW THE TYPICAL CHANNELS	DATE	3/11/12



Client/Project
UJA FEDERATION OF NEW YORK
UJA Bedi River Day Camp
Proposed Improvements
Orangetown, New York

Title
DRY DETENTION BASIN CROSS SECTIONS
SW MANAGEMENT IMPROVEMENTS
Drawing No. C-401-SW 8 of 12
Revision 6

Copyright Reserved
The contractor shall retain and be responsible for all drawings, data, reports, and other information submitted to or received from the contractor. No part of this drawing shall be reproduced, stored in a retrieval system, or transmitted in any form or by any means, electronic, mechanical, photocopying, recording, or by any information storage and retrieval system, without the prior written permission of Stantec.

COMPLIANCE

Legend

Notes

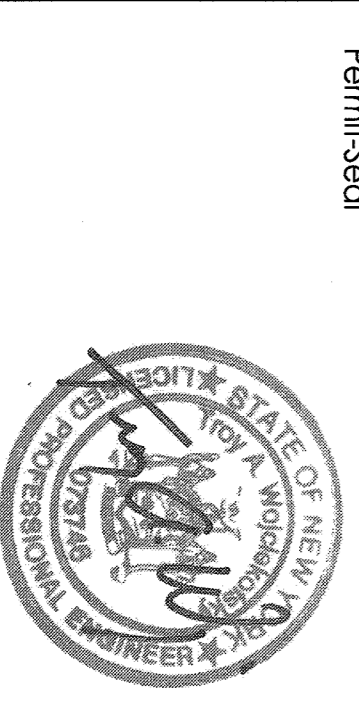

Client/Project
UJA FEDERATION OF NEW YORK
UJA Red River Day Camp
Proposed Improvements
Owego, New York

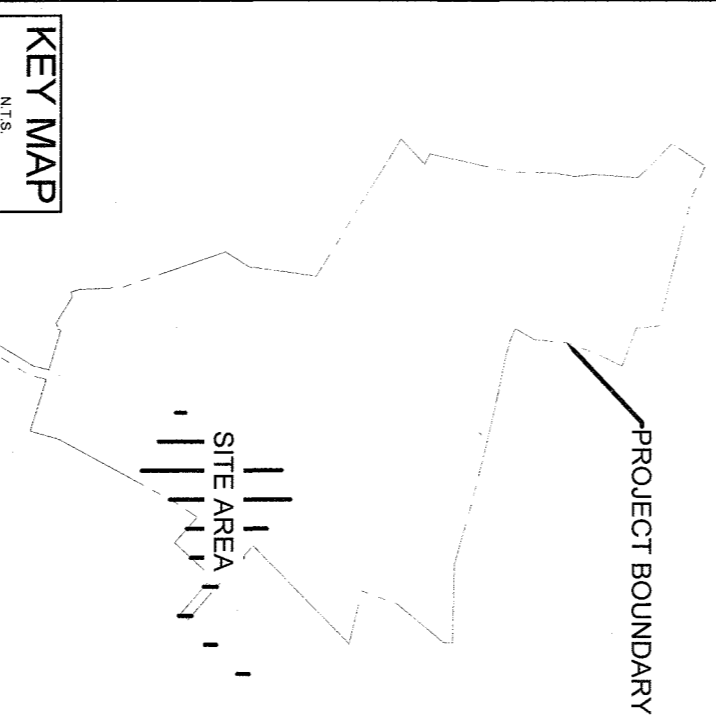

KEY MAP

NO.	DESCRIPTION	DATE	BY	CHKD.
1	REVISED THE TOWN COMMAITS	1/11/11	MM	MM
2	REVISED THE TOWN COMMAITS	1/11/11	MM	MM
3	REVISED THE TOWN COMMAITS	1/11/11	MM	MM
4	REVISED THE TOWN COMMAITS	1/11/11	MM	MM
5	REVISED THE TOWN COMMAITS	1/11/11	MM	MM
6	REVISED THE TOWN COMMAITS	1/11/11	MM	MM
7	REVISED THE TOWN COMMAITS	1/11/11	MM	MM
8	REVISED THE TOWN COMMAITS	1/11/11	MM	MM
9	REVISED THE TOWN COMMAITS	1/11/11	MM	MM
10	REVISED THE TOWN COMMAITS	1/11/11	MM	MM
11	REVISED THE TOWN COMMAITS	1/11/11	MM	MM
12	REVISED THE TOWN COMMAITS	1/11/11	MM	MM
13	REVISED THE TOWN COMMAITS	1/11/11	MM	MM
14	REVISED THE TOWN COMMAITS	1/11/11	MM	MM
15	REVISED THE TOWN COMMAITS	1/11/11	MM	MM
16	REVISED THE TOWN COMMAITS	1/11/11	MM	MM
17	REVISED THE TOWN COMMAITS	1/11/11	MM	MM
18	REVISED THE TOWN COMMAITS	1/11/11	MM	MM
19	REVISED THE TOWN COMMAITS	1/11/11	MM	MM
20	REVISED THE TOWN COMMAITS	1/11/11	MM	MM
21	REVISED THE TOWN COMMAITS	1/11/11	MM	MM
22	REVISED THE TOWN COMMAITS	1/11/11	MM	MM
23	REVISED THE TOWN COMMAITS	1/11/11	MM	MM
24	REVISED THE TOWN COMMAITS	1/11/11	MM	MM
25	REVISED THE TOWN COMMAITS	1/11/11	MM	MM
26	REVISED THE TOWN COMMAITS	1/11/11	MM	MM
27	REVISED THE TOWN COMMAITS	1/11/11	MM	MM
28	REVISED THE TOWN COMMAITS	1/11/11	MM	MM
29	REVISED THE TOWN COMMAITS	1/11/11	MM	MM
30	REVISED THE TOWN COMMAITS	1/11/11	MM	MM
31	REVISED THE TOWN COMMAITS	1/11/11	MM	MM
32	REVISED THE TOWN COMMAITS	1/11/11	MM	MM
33	REVISED THE TOWN COMMAITS	1/11/11	MM	MM
34	REVISED THE TOWN COMMAITS	1/11/11	MM	MM
35	REVISED THE TOWN COMMAITS	1/11/11	MM	MM
36	REVISED THE TOWN COMMAITS	1/11/11	MM	MM
37	REVISED THE TOWN COMMAITS	1/11/11	MM	MM
38	REVISED THE TOWN COMMAITS	1/11/11	MM	MM
39	REVISED THE TOWN COMMAITS	1/11/11	MM	MM
40	REVISED THE TOWN COMMAITS	1/11/11	MM	MM
41	REVISED THE TOWN COMMAITS	1/11/11	MM	MM
42	REVISED THE TOWN COMMAITS	1/11/11	MM	MM
43	REVISED THE TOWN COMMAITS	1/11/11	MM	MM
44	REVISED THE TOWN COMMAITS	1/11/11	MM	MM
45	REVISED THE TOWN COMMAITS	1/11/11	MM	MM
46	REVISED THE TOWN COMMAITS	1/11/11	MM	MM
47	REVISED THE TOWN COMMAITS	1/11/11	MM	MM
48	REVISED THE TOWN COMMAITS	1/11/11	MM	MM
49	REVISED THE TOWN COMMAITS	1/11/11	MM	MM
50	REVISED THE TOWN COMMAITS	1/11/11	MM	MM
51	REVISED THE TOWN COMMAITS	1/11/11	MM	MM
52	REVISED THE TOWN COMMAITS	1/11/11	MM	MM
53	REVISED THE TOWN COMMAITS	1/11/11	MM	MM
54	REVISED THE TOWN COMMAITS	1/11/11	MM	MM
55	REVISED THE TOWN COMMAITS	1/11/11	MM	MM
56	REVISED THE TOWN COMMAITS	1/11/11	MM	MM
57	REVISED THE TOWN COMMAITS	1/11/11	MM	MM
58	REVISED THE TOWN COMMAITS	1/11/11	MM	MM
59	REVISED THE TOWN COMMAITS	1/11/11	MM	MM
60	REVISED THE TOWN COMMAITS	1/11/11	MM	MM
61	REVISED THE TOWN COMMAITS	1/11/11	MM	MM
62	REVISED THE TOWN COMMAITS	1/11/11	MM	MM
63	REVISED THE TOWN COMMAITS	1/11/11	MM	MM
64	REVISED THE TOWN COMMAITS	1/11/11	MM	MM
65	REVISED THE TOWN COMMAITS	1/11/11	MM	MM
66	REVISED THE TOWN COMMAITS	1/11/11	MM	MM
67	REVISED THE TOWN COMMAITS	1/11/11	MM	MM
68	REVISED THE TOWN COMMAITS	1/11/11	MM	MM
69	REVISED THE TOWN COMMAITS	1/11/11	MM	MM
70	REVISED THE TOWN COMMAITS	1/11/11	MM	MM
71	REVISED THE TOWN COMMAITS	1/11/11	MM	MM
72	REVISED THE TOWN COMMAITS	1/11/11	MM	MM
73	REVISED THE TOWN COMMAITS	1/11/11	MM	MM
74	REVISED THE TOWN COMMAITS	1/11/11	MM	MM
75	REVISED THE TOWN COMMAITS	1/11/11	MM	MM
76	REVISED THE TOWN COMMAITS	1/11/11	MM	MM
77	REVISED THE TOWN COMMAITS	1/11/11	MM	MM
78	REVISED THE TOWN COMMAITS	1/11/11	MM	MM
79	REVISED THE TOWN COMMAITS	1/11/11	MM	MM
80	REVISED THE TOWN COMMAITS	1/11/11	MM	MM
81	REVISED THE TOWN COMMAITS	1/11/11	MM	MM
82	REVISED THE TOWN COMMAITS	1/11/11	MM	MM
83	REVISED THE TOWN COMMAITS	1/11/11	MM	MM
84	REVISED THE TOWN COMMAITS	1/11/11	MM	MM
85	REVISED THE TOWN COMMAITS	1/11/11	MM	MM
86	REVISED THE TOWN COMMAITS	1/11/11	MM	MM
87	REVISED THE TOWN COMMAITS	1/11/11	MM	MM
88	REVISED THE TOWN COMMAITS	1/11/11	MM	MM
89	REVISED THE TOWN COMMAITS	1/11/11	MM	MM
90	REVISED THE TOWN COMMAITS	1/11/11	MM	MM
91	REVISED THE TOWN COMMAITS	1/11/11	MM	MM
92	REVISED THE TOWN COMMAITS	1/11/11	MM	MM
93	REVISED THE TOWN COMMAITS	1/11/11	MM	MM
94	REVISED THE TOWN COMMAITS	1/11/11	MM	MM
95	REVISED THE TOWN COMMAITS	1/11/11	MM	MM
96	REVISED THE TOWN COMMAITS	1/11/11	MM	MM
97	REVISED THE TOWN COMMAITS	1/11/11	MM	MM
98	REVISED THE TOWN COMMAITS	1/11/11	MM	MM
99	REVISED THE TOWN COMMAITS	1/11/11	MM	MM
100	REVISED THE TOWN COMMAITS	1/11/11	MM	MM
101	REVISED THE TOWN COMMAITS	1/11/11	MM	MM
102	REVISED THE TOWN COMMAITS	1/11/11	MM	MM
103	REVISED THE TOWN COMMAITS	1/11/11	MM	MM
104	REVISED THE TOWN COMMAITS	1/11/11	MM	MM
105	REVISED THE TOWN COMMAITS	1/11/11	MM	MM
106	REVISED THE TOWN COMMAITS	1/11/11	MM	MM
107	REVISED THE TOWN COMMAITS	1/11/11	MM	MM
108	REVISED THE TOWN COMMAITS	1/11/11	MM	MM
109	REVISED THE TOWN COMMAITS	1/11/11	MM	MM
110	REVISED THE TOWN COMMAITS	1/11/11	MM	MM

Permit/Scale
Permit: 5641
Scale: 1"=20'

Project No.
1931.1936

Sheet
10 of 12

Revision
6

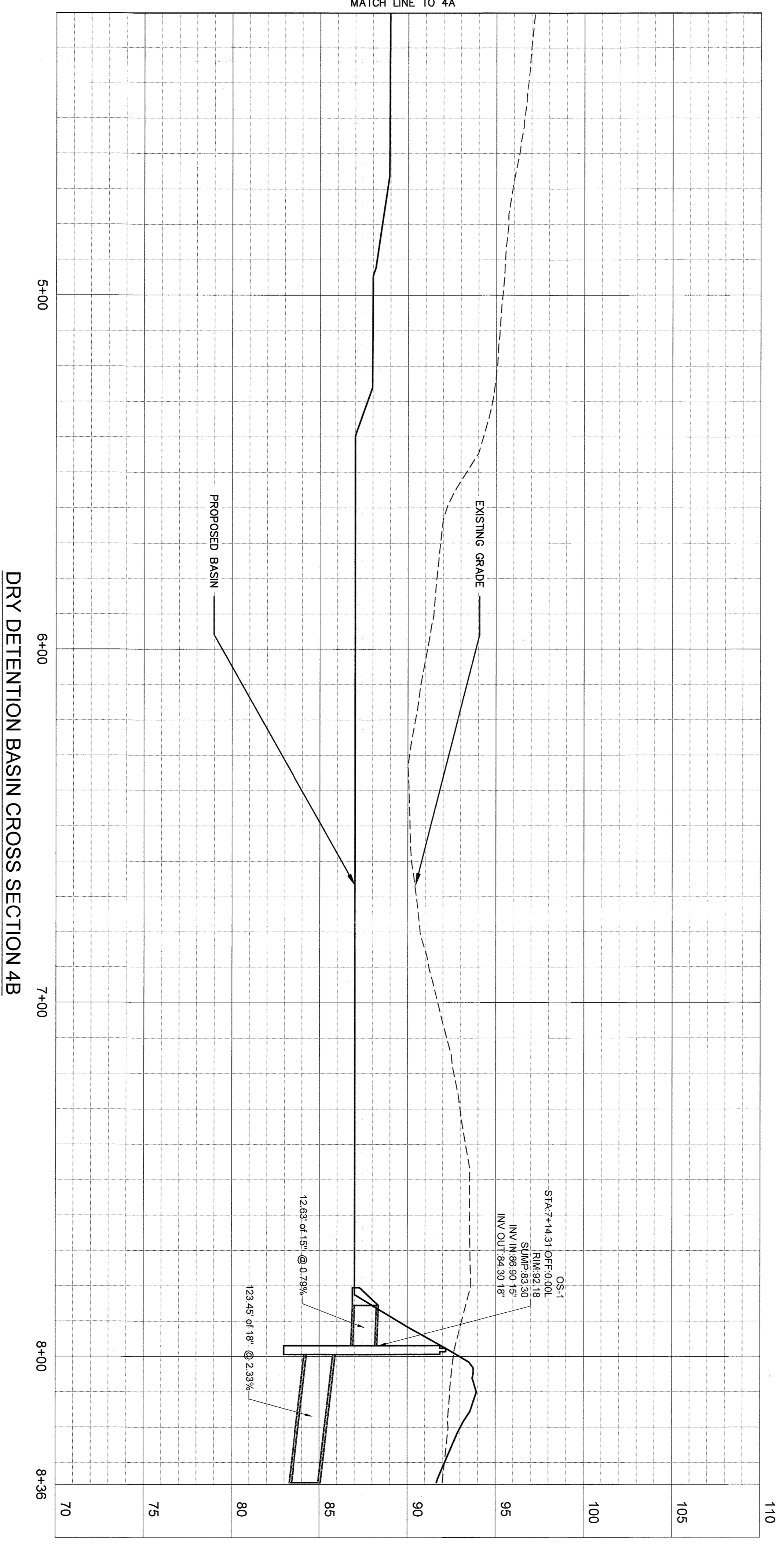
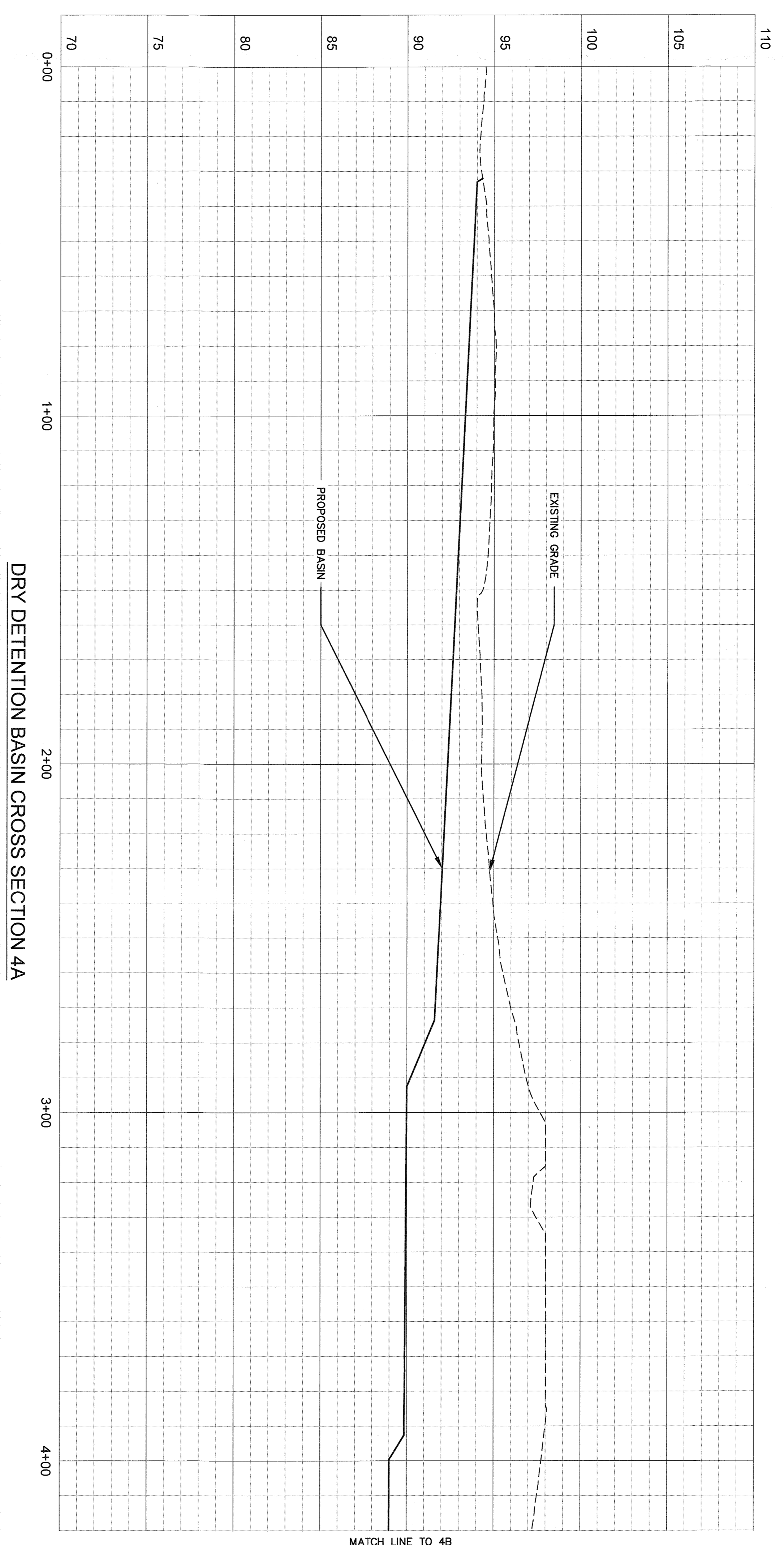

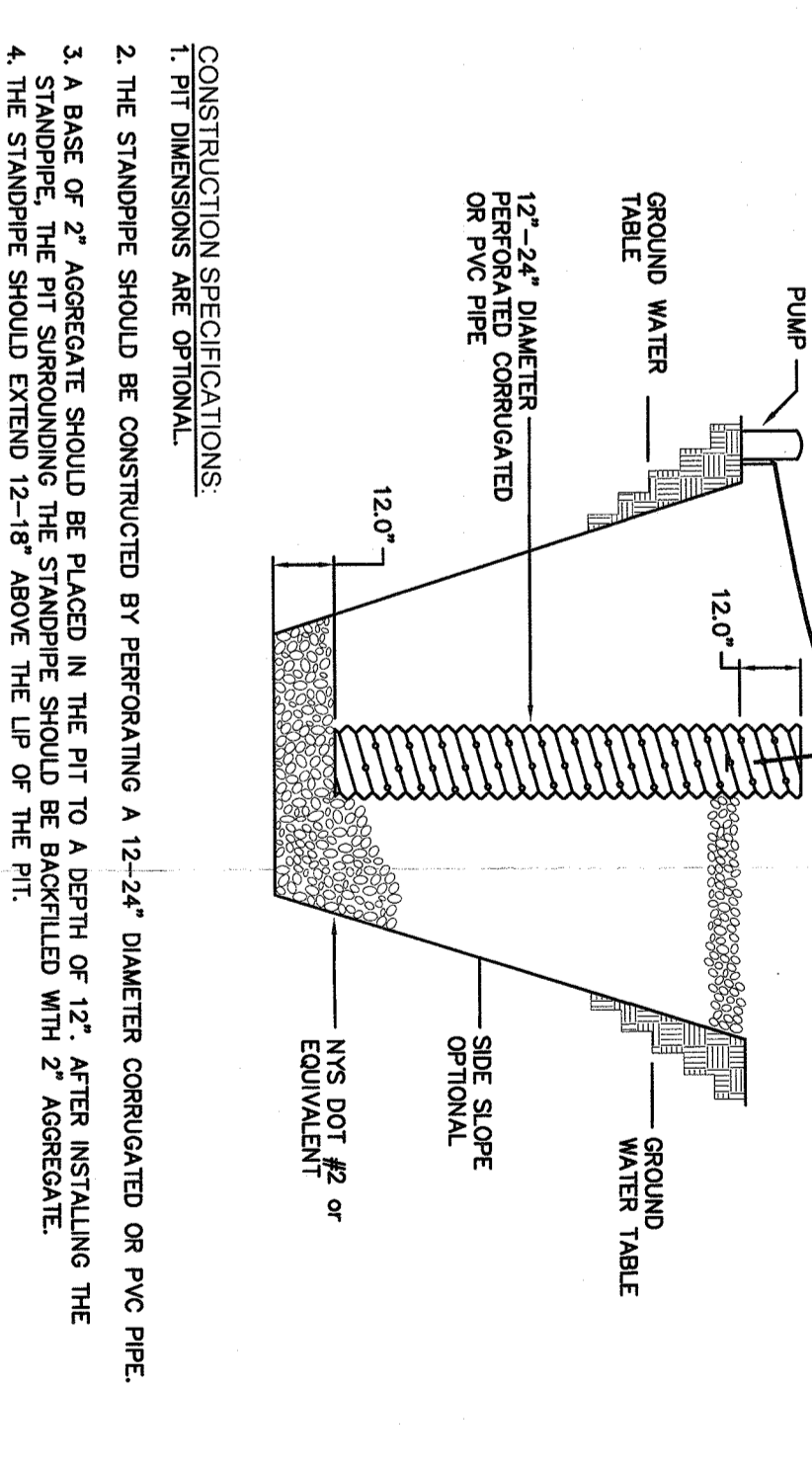

4 SUMP PIT
NOT TO SCALE

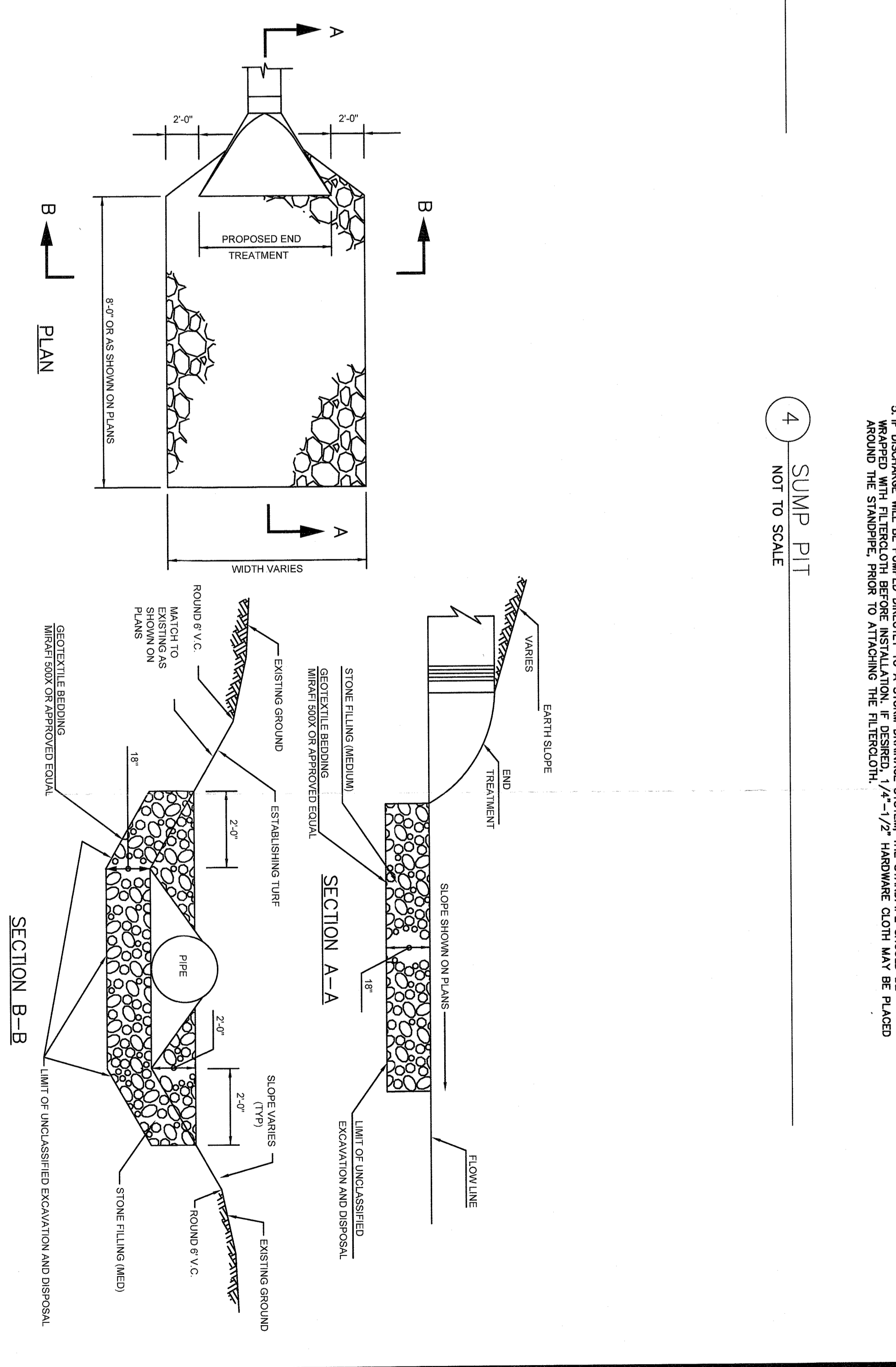

8 INLET/OUTLET CULVERT RIP-RAP APRONS
NOT TO SCALE

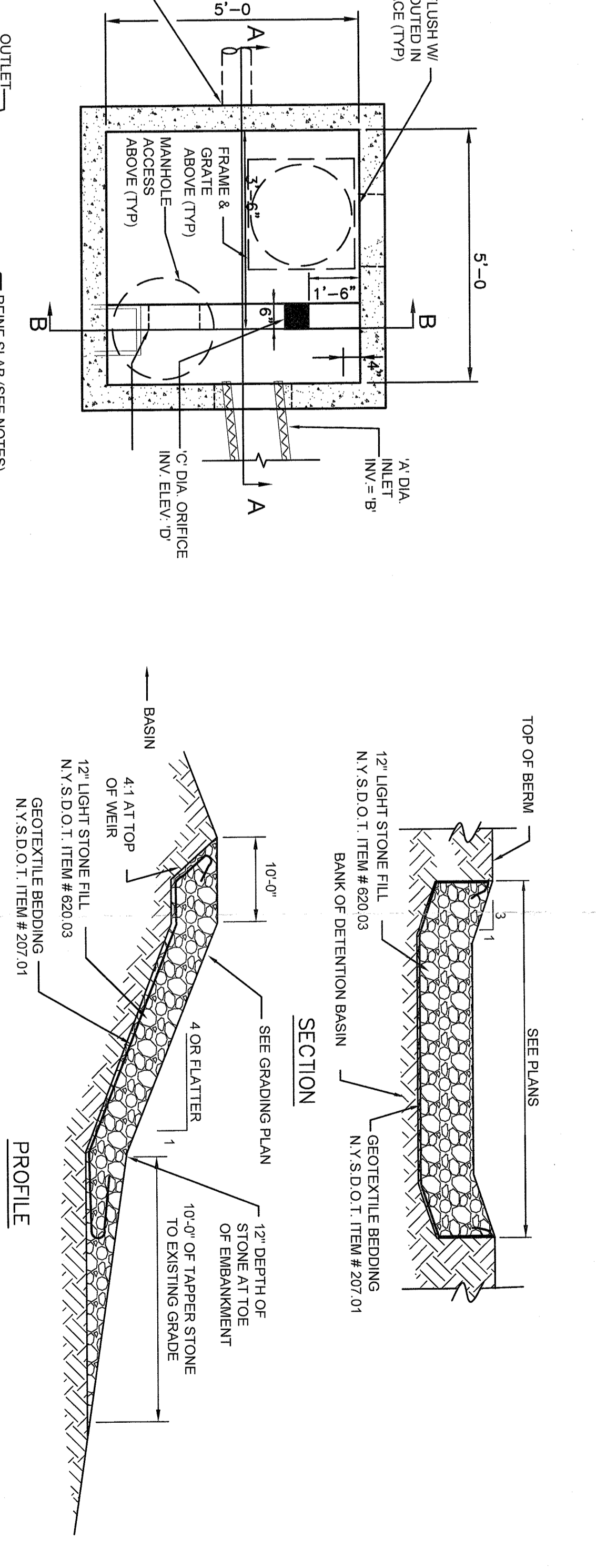

12 EMERGENCY SPILLWAY
NOT TO SCALE

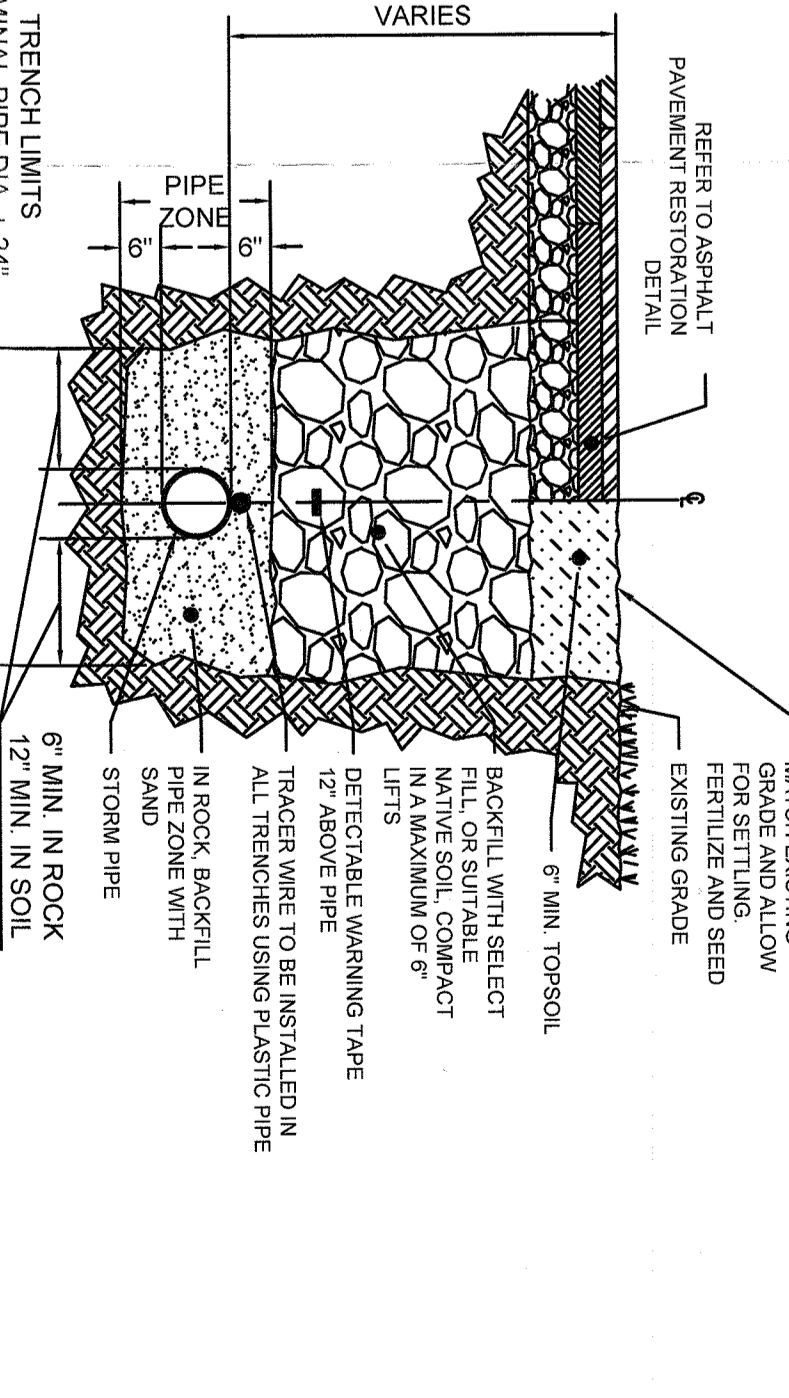

13 PIPE TRENCH DETAIL
NOT TO SCALE

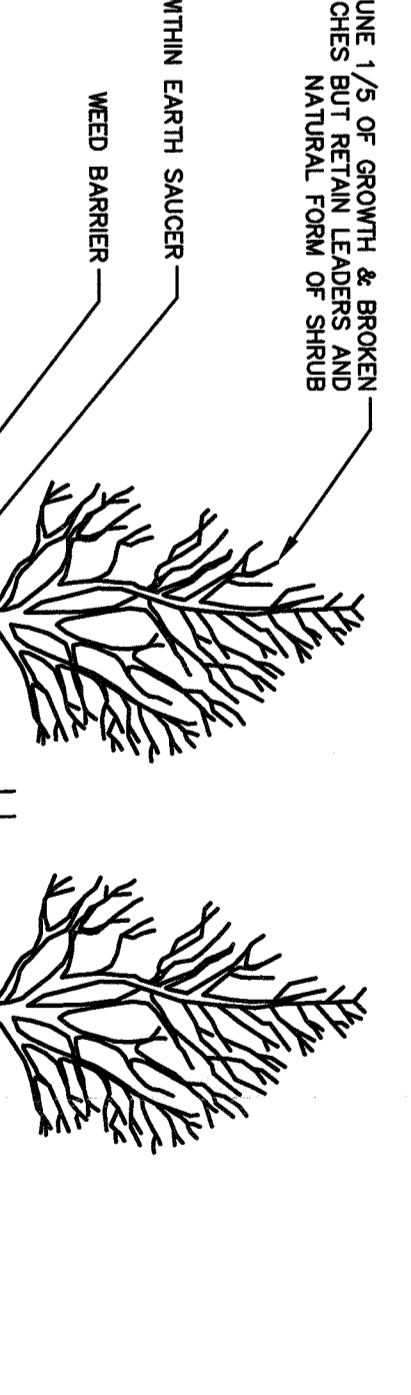

19 DECIDUOUS TREE PLANTING DETAIL
NOT TO SCALE

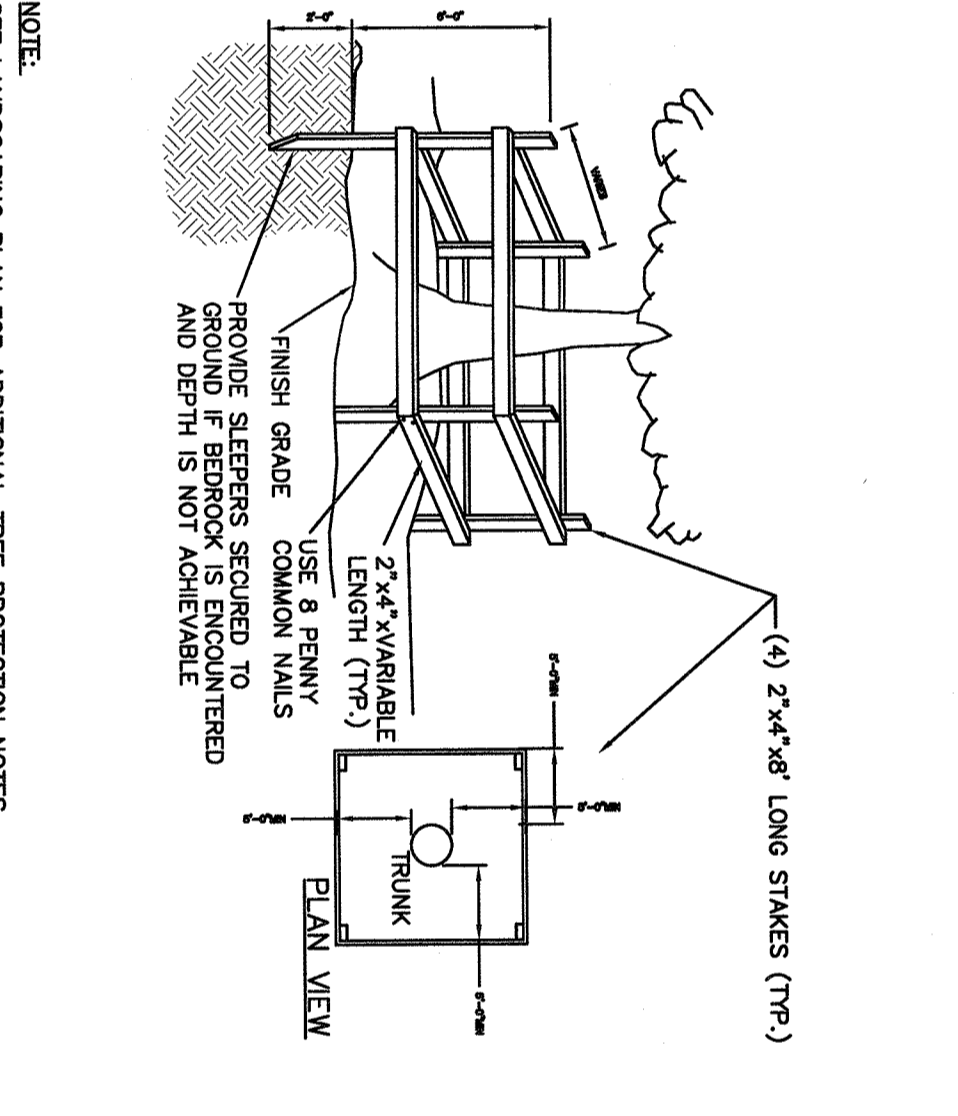

3 TEMPORARY TREE PROTECTION
NOT TO SCALE

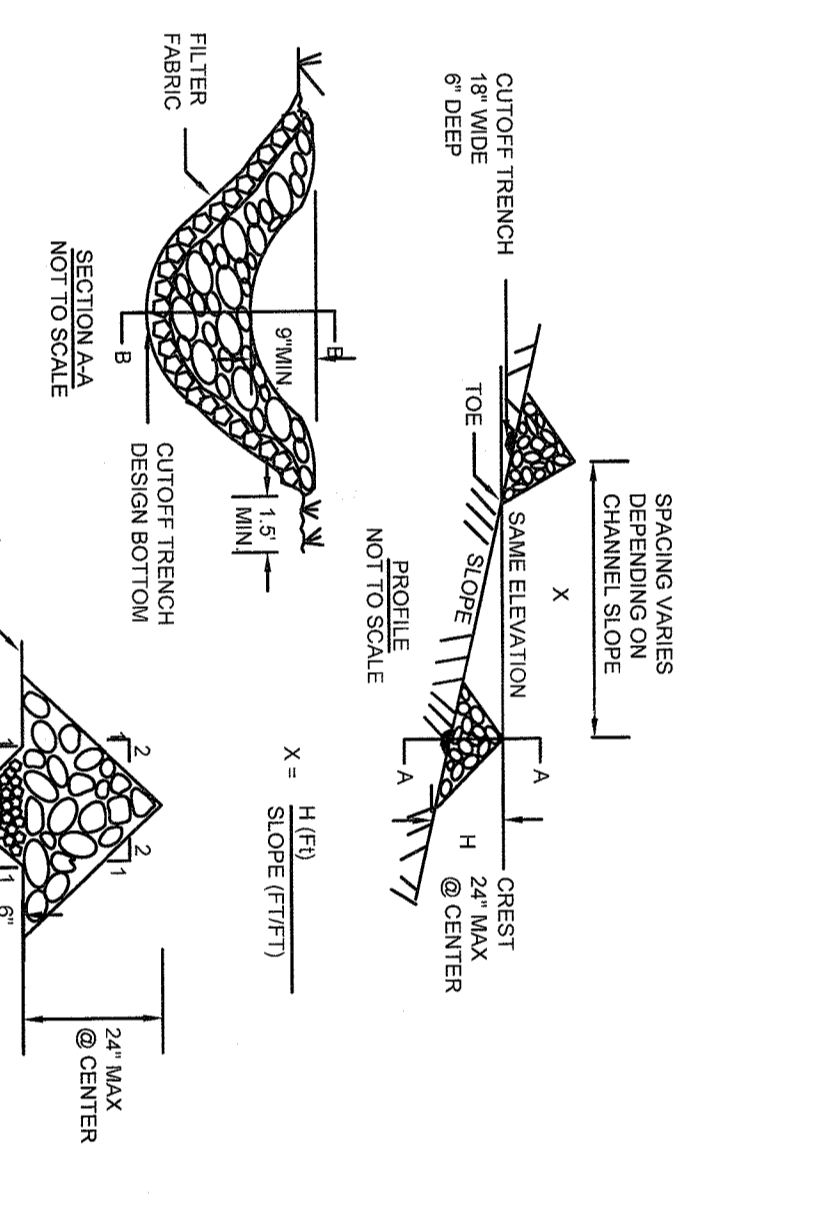

7 CHECK DAM
NOT TO SCALE

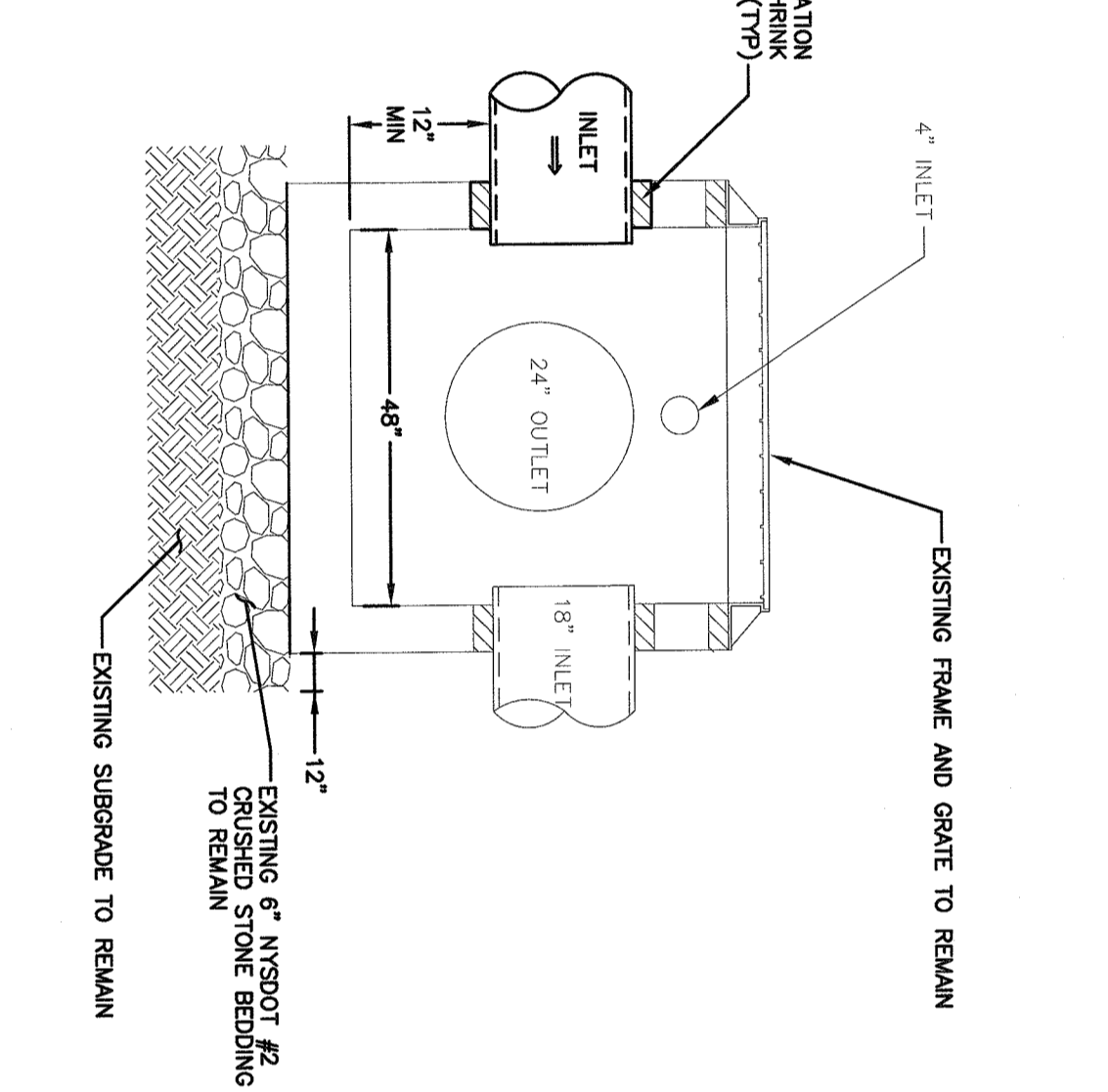

10 EXISTING CATCH BASIN TIE-IN
NOT TO SCALE

ORGANIZER BASIN	A	B	C	D	E	F	G	H	I
CS-1	15'	80.9	6'	87.0	88.0	42'	15'	84.3	83.1

11 OUTLET CONTROL STRUCTURE
NOT TO SCALE

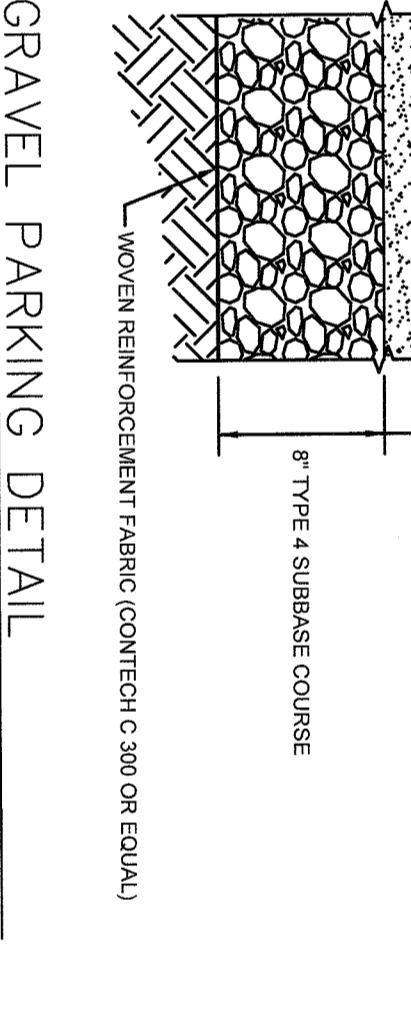

17 GRAVEL PARKING DETAIL
NOT TO SCALE

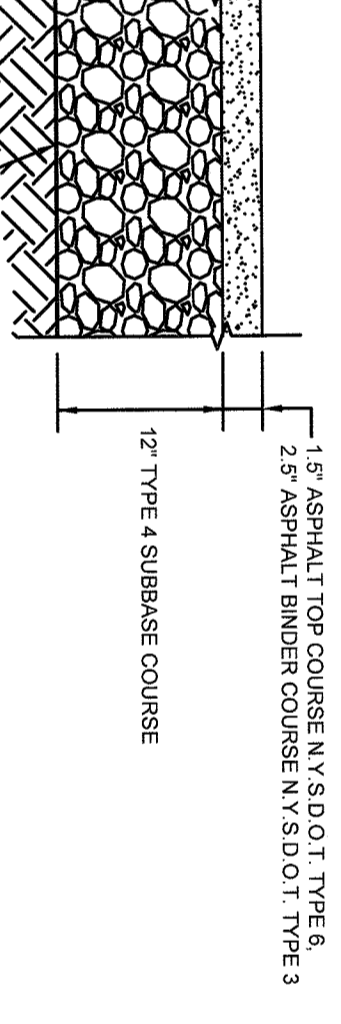

18 ASPHALT PAVING DETAIL
NOT TO SCALE

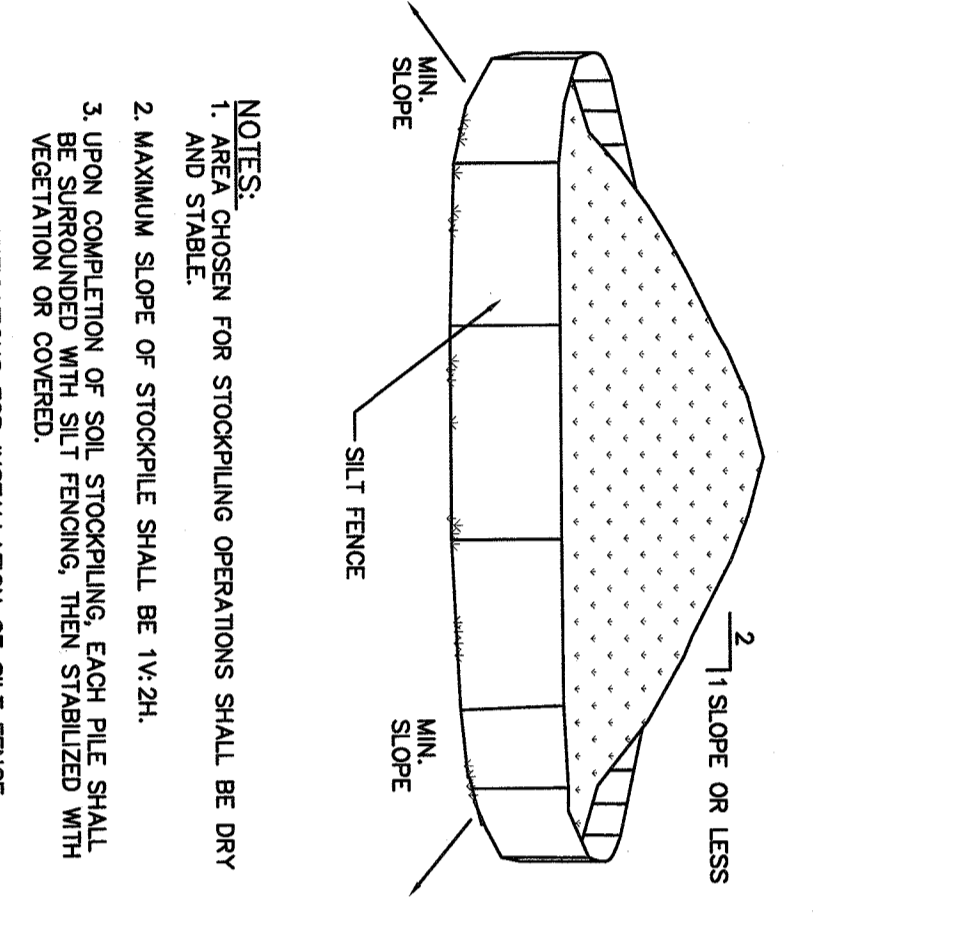

2 TEMPORARY SOIL STOCKPILE
NOT TO SCALE

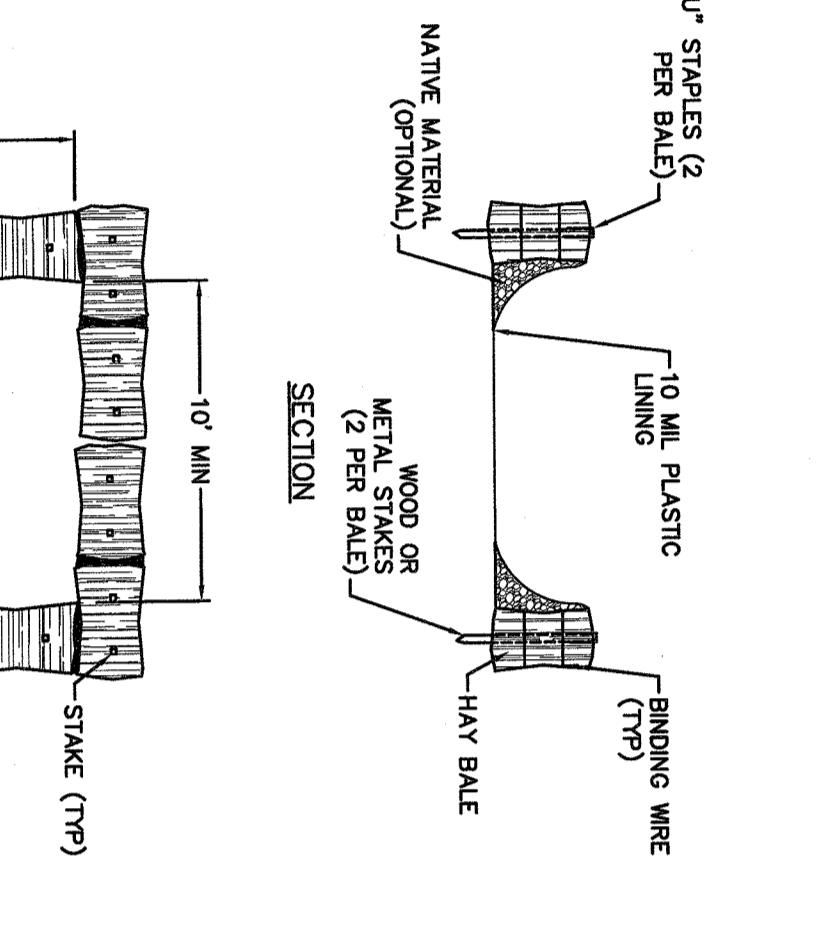

6 ABOVE-GROUND TEMPORARY CONCRETE WASHOUT FACILITY
NOT TO SCALE

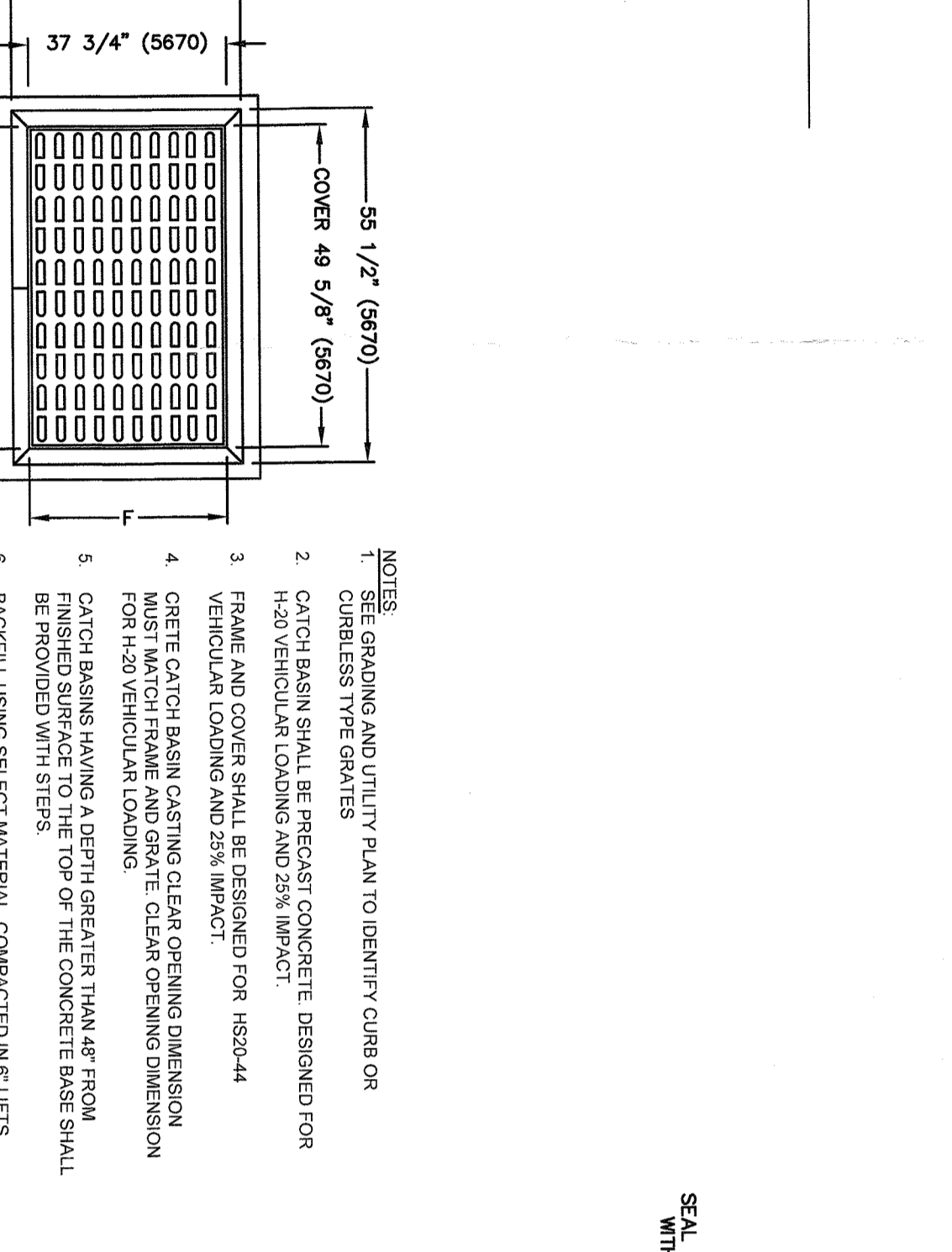

5 STABILIZED CONSTRUCTION ENTRANCE
NOT TO SCALE

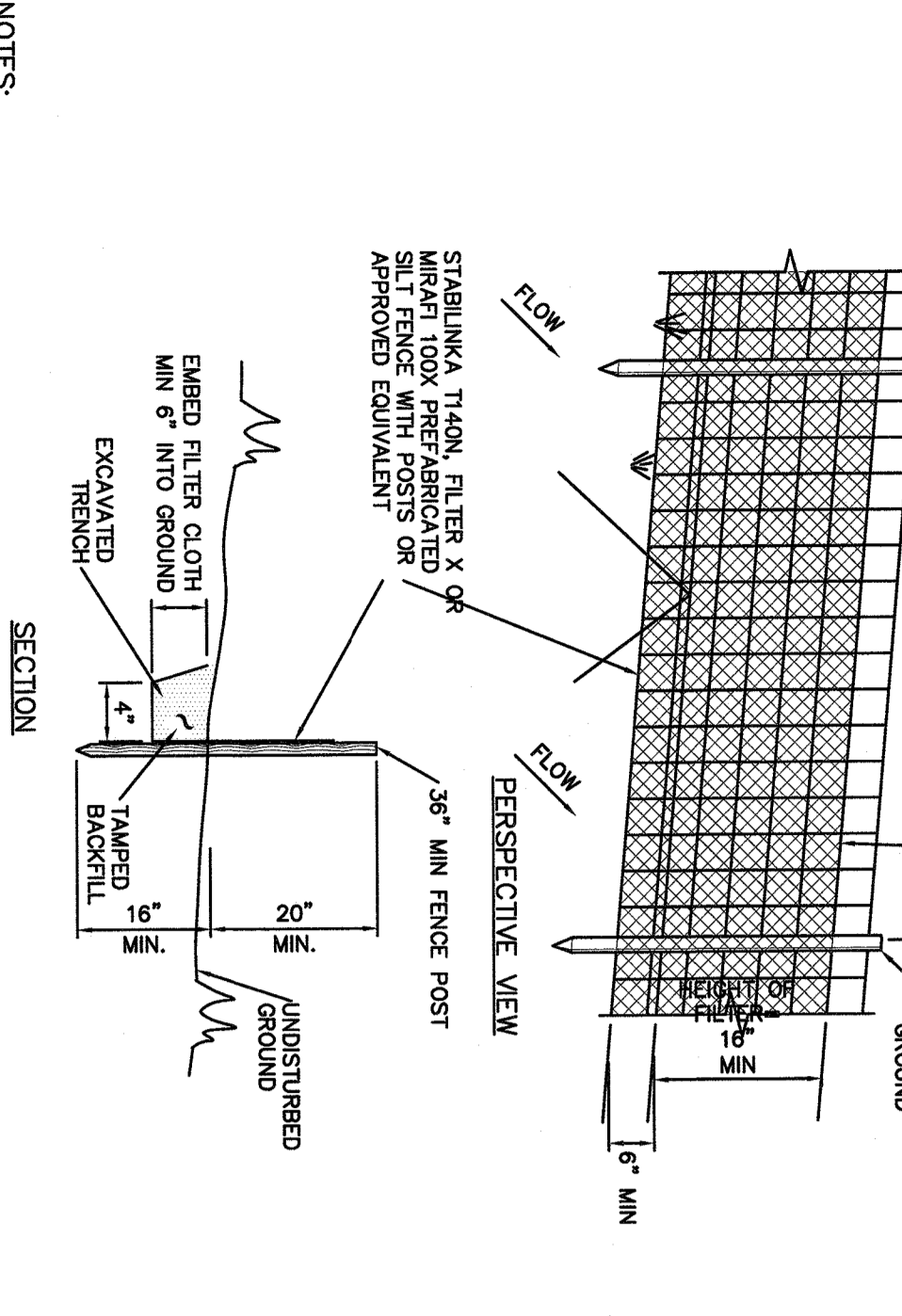

1 SILT FENCE INSTALLATION
NOT TO SCALE

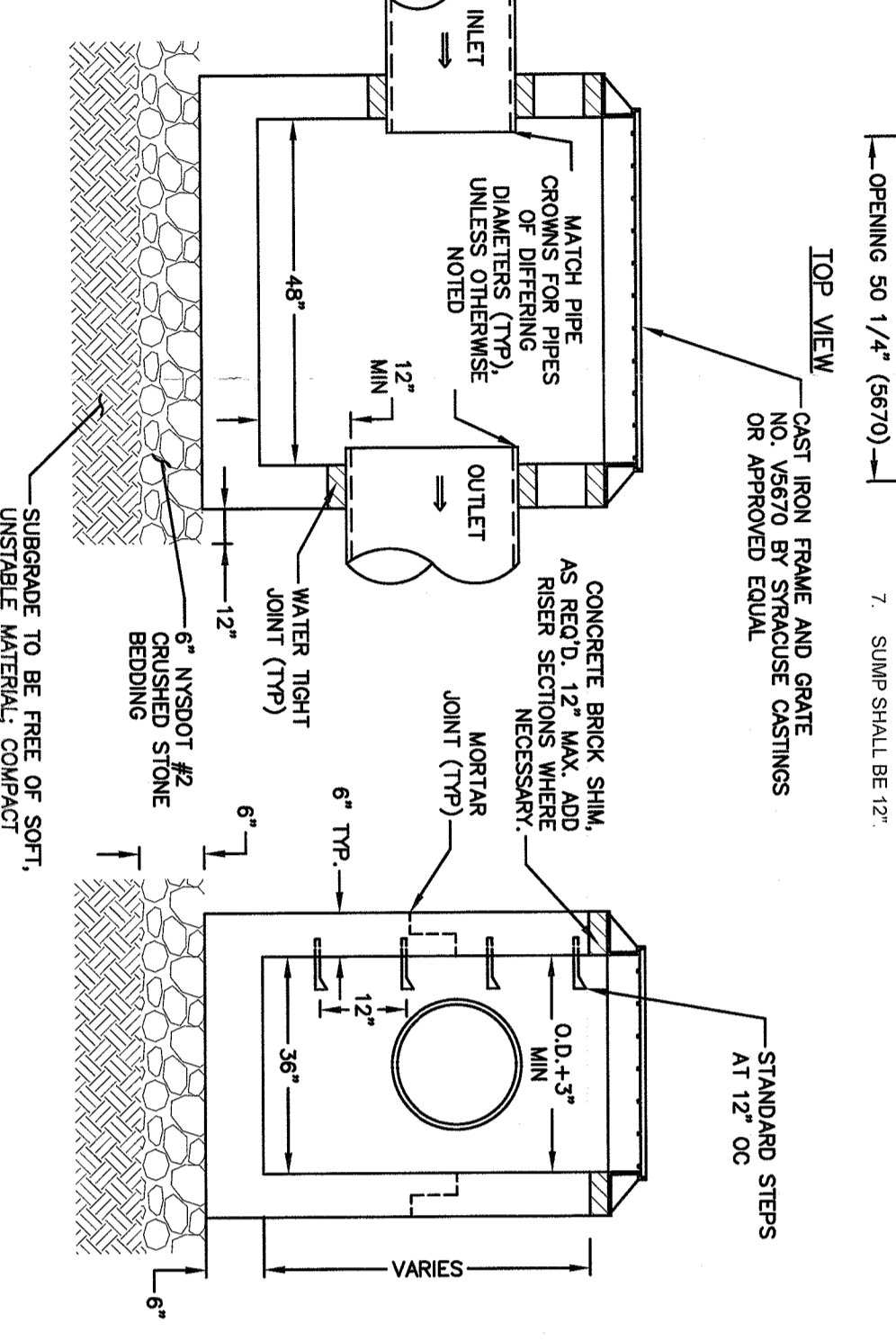

10 PRECAST CONCRETE CATCH BASIN
NOT TO SCALE

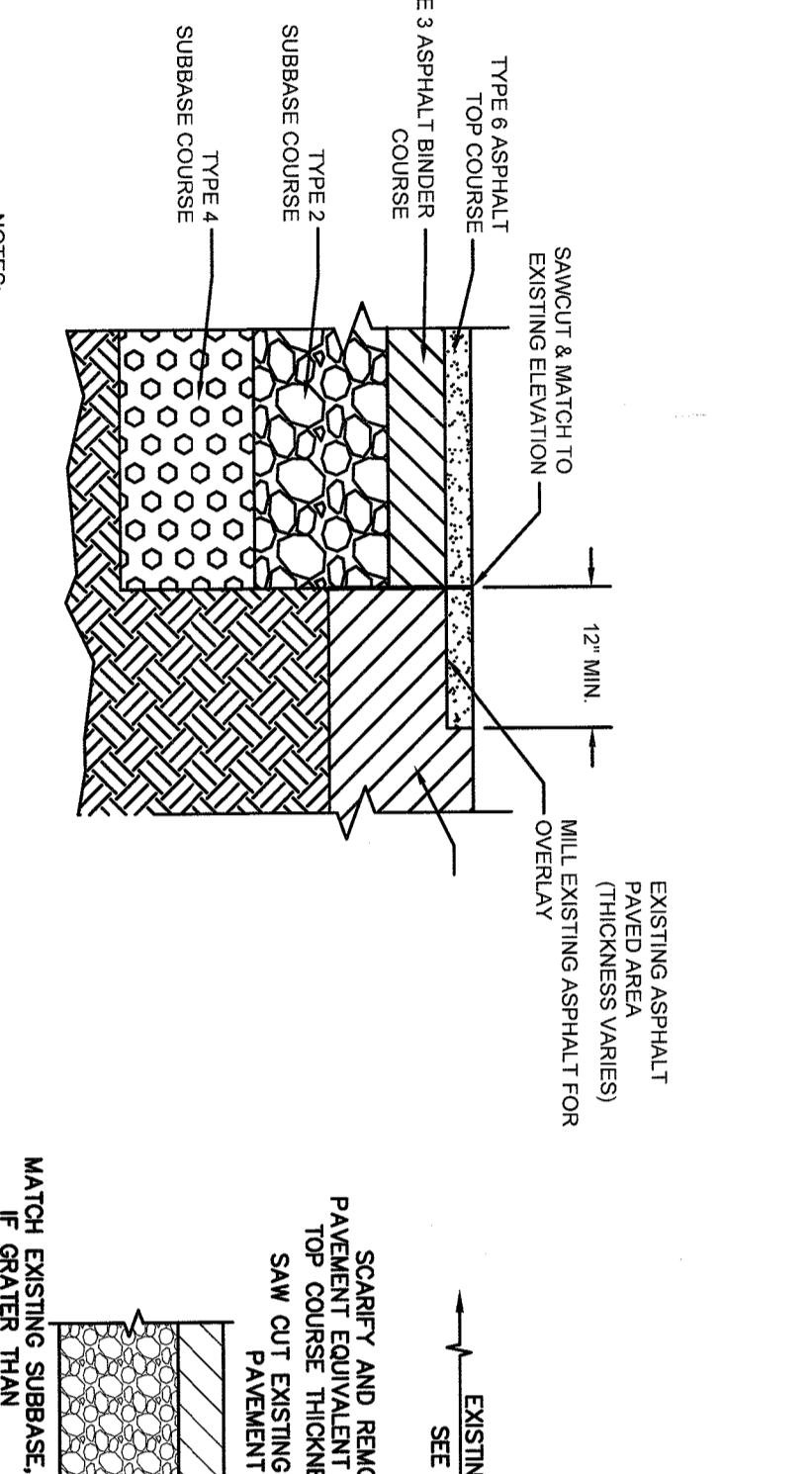

15 ASPHALT SAWCUT
NOT TO SCALE

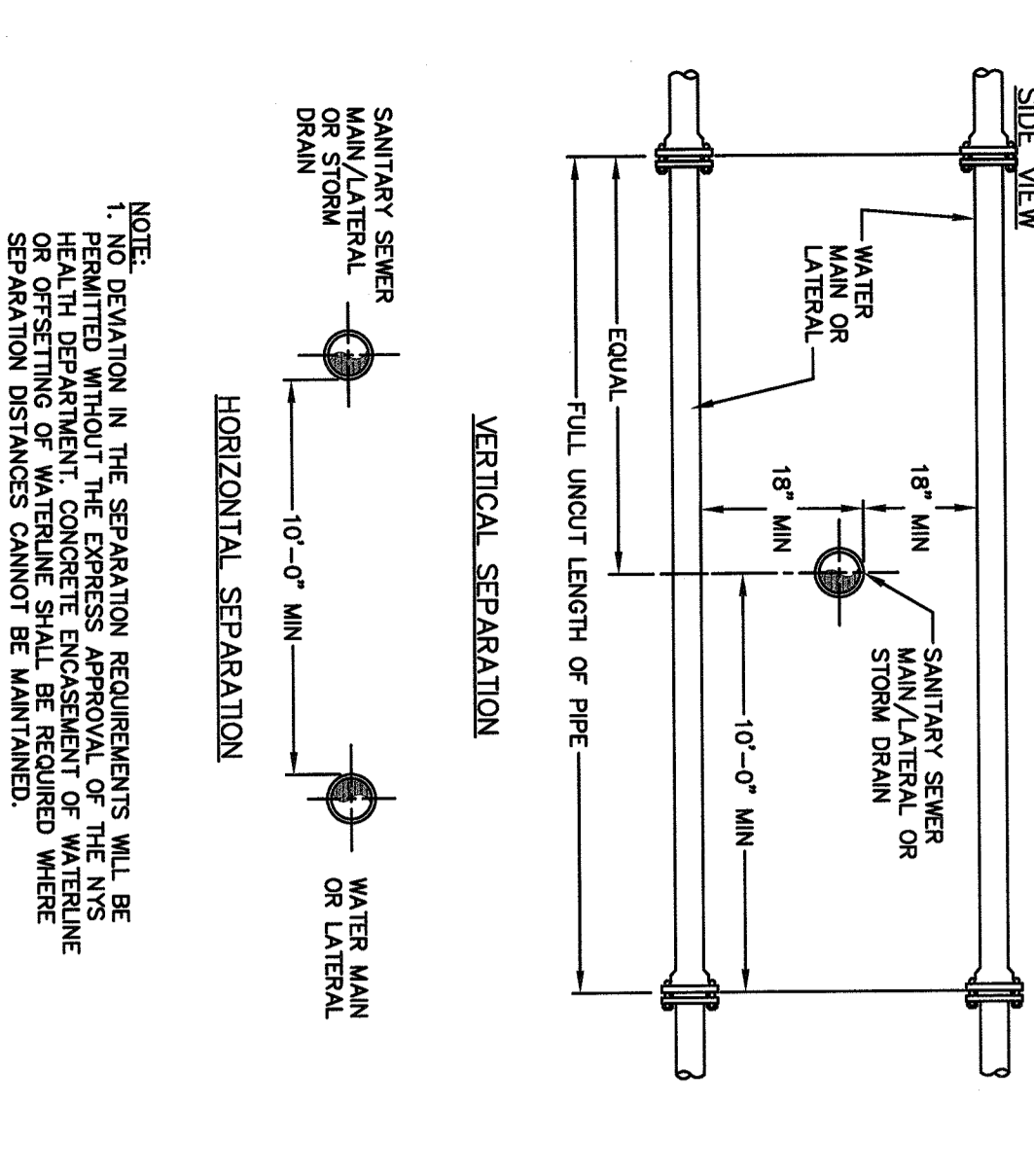

14 SANITARY/STORM & WATERMAIN SEPARATION
NOT TO SCALE

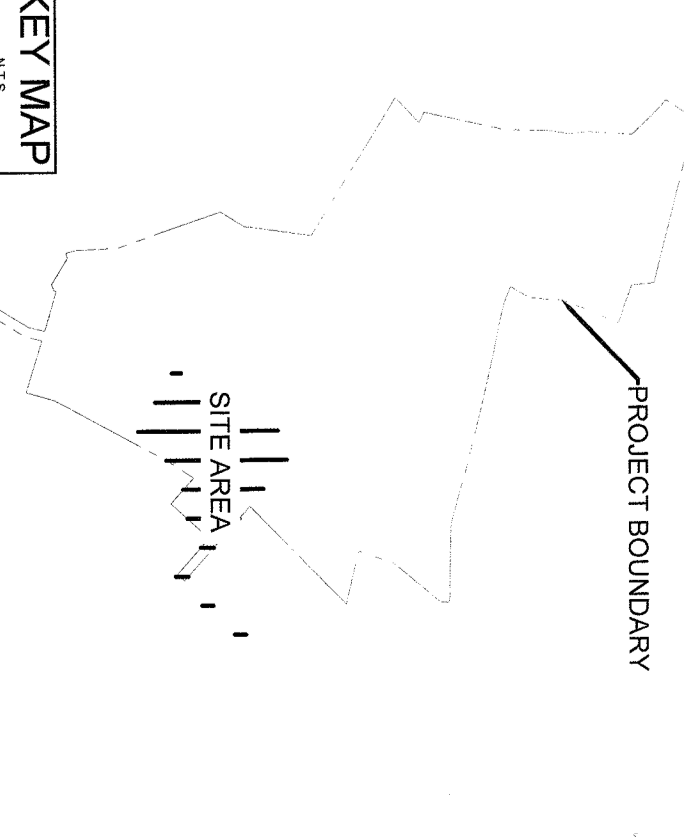

KEY MAP	NO.	DATE	DESCRIPTION
1	10/11/11	10/11/11	1. REVISION TO CONSTRUCTION
2	10/11/11	10/11/11	2. REVISION TO CONSTRUCTION
3	10/11/11	10/11/11	3. REVISION TO CONSTRUCTION
4	10/11/11	10/11/11	4. REVISION TO CONSTRUCTION
5	10/11/11	10/11/11	5. REVISION TO CONSTRUCTION
6	10/11/11	10/11/11	6. REVISION TO CONSTRUCTION
7	10/11/11	10/11/11	7. REVISION TO CONSTRUCTION
8	10/11/11	10/11/11	8. REVISION TO CONSTRUCTION
9	10/11/11	10/11/11	9. REVISION TO CONSTRUCTION
10	10/11/11	10/11/11	10. REVISION TO CONSTRUCTION
11	10/11/11	10/11/11	11. REVISION TO CONSTRUCTION
12	10/11/11	10/11/11	12. REVISION TO CONSTRUCTION
13	10/11/11	10/11/11	13. REVISION TO CONSTRUCTION
14	10/11/11	10/11/11	14. REVISION TO CONSTRUCTION
15	10/11/11	10/11/11	15. REVISION TO CONSTRUCTION
16	10/11/11	10/11/11	16. REVISION TO CONSTRUCTION
17	10/11/11	10/11/11	17. REVISION TO CONSTRUCTION
18	10/11/11	10/11/11	18. REVISION TO CONSTRUCTION
19	10/11/11	10/11/11	19. REVISION TO CONSTRUCTION
20	10/11/11	10/11/11	20. REVISION TO CONSTRUCTION

DETAILS
SW MANAGEMENT IMPROVEMENTS
195115985
AS SHOWN
Revision

Client/Project
UJA FEDERATION OF NEW YORK
UJA Pearl River Day Camp
Proposed Improvements
Oysterbrook, New York

Permit/Seal
195115985
AS SHOWN

Title
SW MANAGEMENT IMPROVEMENTS
195115985
AS SHOWN

Project No.
195115985

Sheet
AS SHOWN

Revision
6

D-100-SW 12 of 12

195115985

AS SHOWN

Revision

6

D-100-SW 12 of 12

195115985

AS SHOWN

Revision

6

D-100-SW 12 of 12

195115985

AS SHOWN

Revision

6

D-100-SW 12 of 12

195115985

AS SHOWN

Revision

6

D-100-SW 12 of 12

195115985

AS SHOWN

Revision

6

D-100-SW 12 of 12

195115985

AS SHOWN

Revision

6

D-100-SW 12 of 12

195115985

AS SHOWN

Revision

6

D-100-SW 12 of 12

195115985

AS SHOWN

Revision

6

D-100-SW 12 of 12

195115985

AS SHOWN

Revision

6

D-100-SW 12 of 12

195115985

AS SHOWN

Revision

6

D-100-SW 12 of 12

195115985

AS SHOWN

Revision

6

D-100-SW 12 of 12

195115985

AS SHOWN

Revision

6

D-100-SW 12 of 12

195115985

AS SHOWN

Revision

6

D-100-SW 12 of 12

195115985

AS SHOWN

Revision

6

D-100-SW 12 of 12

195115985

AS SHOWN

Revision

6

D-100-SW 12 of 12

195115985

AS SHOWN

Revision

6

D-100-SW 12 of 12

195115985

AS SHOWN

Revision

6

D-100-SW 12 of 12

195115985

AS SHOWN

Revision

6

D-100-SW 12 of 12

195115985

AS SHOWN

Revision

6

D-100-SW 12 of 12

195115985

AS SHOWN

Revision

6

D-100-SW 12 of 12

195115985

AS SHOWN

Revision

6

D-100-SW 12 of 12

195115985

AS SHOWN

Revision

6

D-100-SW 12 of 12

195115985

AS SHOWN

Revision

6

D-100-SW 12 of 12

195115985

AS SHOWN

Revision

6

D-100-SW 12 of 12

195115985

AS SHOWN

Revision

6

D-100-SW 12 of 12

195115985

AS SHOWN

Revision

6

D-100-SW 12 of 12

195115985

AS SHOWN

Revision

6

D-100-SW 12 of 12

195115985

AS SHOWN

Revision

6

D-100-SW 12 of 12

195115985

AS SHOWN

Revision

6

D-100-SW 12 of 12

195115985

AS SHOWN

Revision

6

D-100-SW 12 of 12

195115985

AS SHOWN

Revision

6

D-100-SW 12 of 12

195115985

AS SHOWN

Revision

6

D-100-SW 12 of 12

195115985

AS SHOWN

Revision

6

D-100-SW 12 of 12

195115985

AS SHOWN

Revision

6

D-100-SW 12 of 12

195115985

AS SHOWN

Revision

6

D-100-SW 12 of 12

195115985

AS SHOWN

Revision

6

D-100-SW 12 of 12

195115985

AS SHOWN

Revision

6

D-100-SW 12 of 12

195115985

AS SHOWN

Revision

6

D-100-SW 12 of 12

19511598