

# GREAT AMERICAN CLEANUP

*Orangetown & Tappan*



**KEEP  
ROCKLAND  
BEAUTIFUL**



- All supplies provided for a safe & effective cleanup
- Kid friendly sites
- Company team building
- Community service hours
- Fun for all ages!



Tappan Firehouse  
123 Washington Street  
Tappan, NY  
**9am-12pm**  
**Rain or Shine!**

**APRIL | 6<sup>th</sup> | 2024**

Breakfast will be provided by the firehouse during check-in and buffet lunch will be at The NoCo Kitchen after the cleanup!

Questions Contact:  
George Garrecht IV  
Phone: 845-721-5320

Email: [clemgolf21@hotmail.com](mailto:clemgolf21@hotmail.com)

Register online:  
[KeepRocklandBeautiful.org](http://KeepRocklandBeautiful.org)



**~ Caverns of the Mind ~ Mother Earth ~ Ravage not its gifts, nor its inhabitants...**

And here in the NOW of Deliverance as promised... Caverns of the MIND ... life is breath, a pulse, we all bleed red... a flow... and so we, it, a watercolor painting ... a flow, a pulse, a consciousness.

May our awareness, our discernment, our knowing wise, as a community of people from all parts of this Earth, bring a restorative reverence to Mother Nature, her Divine intelligence and Supernal Creation.

Let us rise above the corporate greed and impeding control ... of those who ravage Mother Earth by pesticides, toxins, poisons, manipulation of energy patterns.

We are more in numbers, more with endowed power, more with right intention, and are to appreciate WE ARE THE CHANGE that is to BE!!! WE, Humanity, Mother Earth deserve no less... all with blessings and supernal love...

Mother Earth ~ Ravage not its gifts, nor its inhabitants...

Inspired Spirit and Blessings shall prevail  
There is a Supernal Love beyond travail

That knowing faith within heart  
From which a questing peace has its start

A vision beyond the perceived despair  
So be our wondrous destiny in GOD's loving care

Light and TRUTH be they the resounding plea  
Over our lands, heart to heart, from sea to sea

Gather our thoughts and a new vision clear  
Beyond all illusions beyond all fear.

Ravage not the land nor sea  
Heed the echoed cry and plea

Heard in the crashing wave and thunderous sky  
In valleys, plains and mountains high

Hold this Earth in reverent care  
Protect our gifts of water and air

Take not in abuse a mineral or gem  
Behold the wonder of each bloom, leaf and stem

Trees to flourish, 'tis bounty's call  
The knowing grace of Winter, Spring, Summer, Fall

Earth, animals, plants, a you, a me  
Nurture wise and abundance be.

**Rose Marie Raccioppi  
Poet Laureate  
Orangetown, New York**

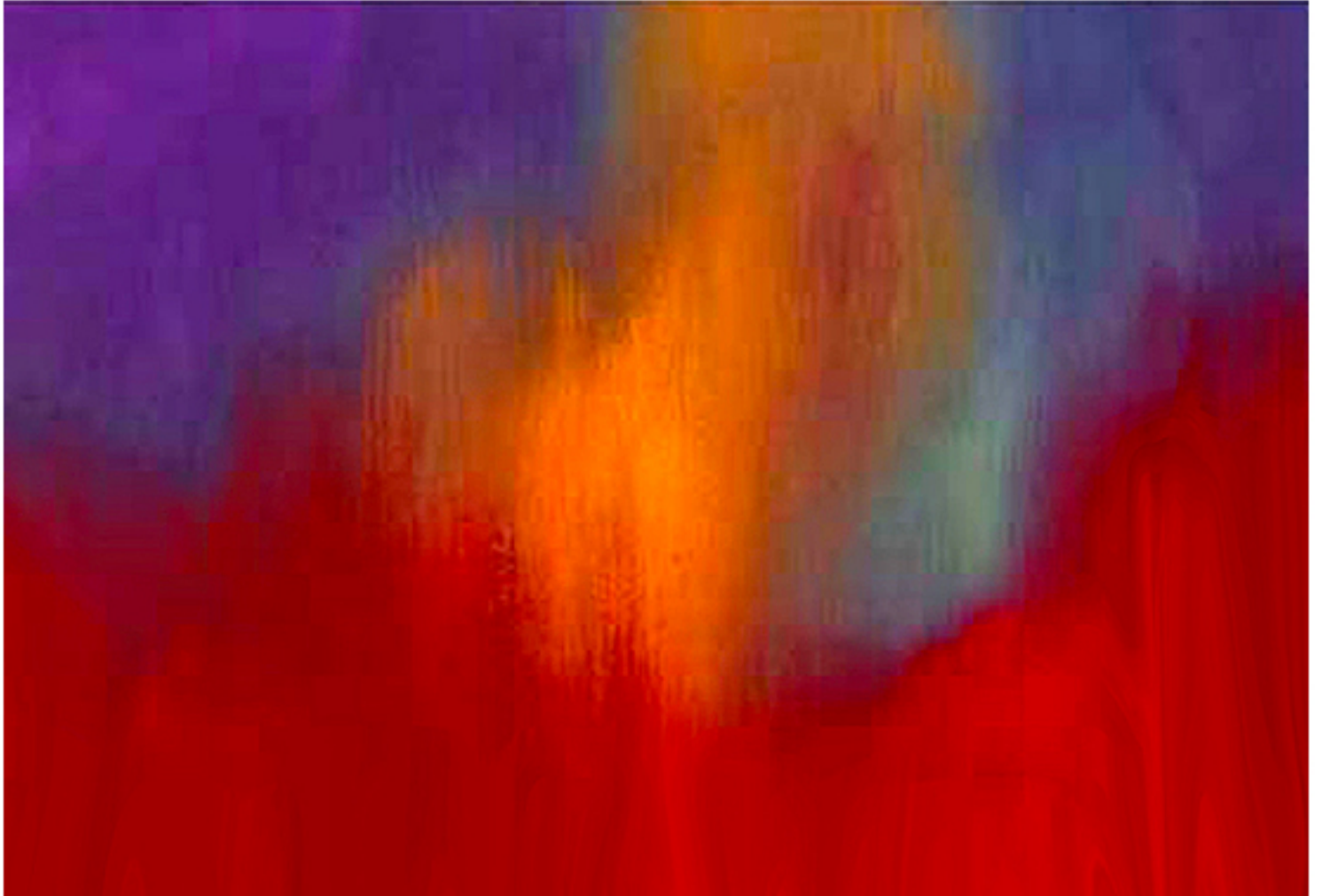



**110 WEST CROOKED HILL ROAD (O-2486)**

- 3 Contractor's storage yards are permitted within the LI zoning district, subject to the requirements under Chapter 43, Section 8.10 of the Orangetown code. However, despite this being a permissible use within the LI district, it is not listed under the Table of General Use Regulations per Chapter 43, Section 3.1 (Attachment 7). It is recommended that the Table of General Use Regulations be updated to include contractor's storage yards.
- 4 We request the opportunity to review any subsequent site plan reviews concerning the contractor's storage yard as required by General Municipal Law.
- 5 Two questions on the Short Environmental Assessment Form (SEAF) are answered incorrectly. The EAF Mapper Application, provided by the New York State Department of Environmental Conservation (<https://gisservices.dec.ny.gov/eafmapper/>), indicates that questions 13a. and 20 on the SEAF should be answered affirmatively. To ensure accurate SEQRA documentation, the Town must encourage applicants to use this tool to complete the SEAF as it populates the answers to certain questions using New York State database information. Information about remediation (Question 20) can be found by using the using the DECinfo Locator (<https://gisservices.dec.ny.gov/gis/dil/>).
- 6 The following additional comment is offered strictly as an observation and is not part of our General Municipal Law (GML) review. The Board may have already addressed this point or may disregard it without any formal vote under the GML process:
- 6.1 This application was officially received by the Rockland County Planning Department on March 8, 2024. The application materials indicate that the public hearing will be held on April 2, 2024 - 25 days after the County received the application. As a reminder, State General Municipal Law, Section 239 (m) 4.(b) states that "Such county planning agency or regional planning council, or an authorized agent of said agency or council, shall have thirty days after receipt of a full statement of such proposed action, or such longer period as may have been agreed upon by the county planning agency or regional planning council and the referring body, to report its recommendations to the referring body, accompanied by a statement of the reasons for such recommendations." Adequate time must be provided to the Rockland County Planning Department in order for us to do our review before the public hearing is scheduled and the matter heard before the board.
- 6.2 The GML Referral Form indicates that the property is within 500 feet within a Village, Town, County, or State Boundary, which is not accurate. The GML Referral Form must be corrected, and if any inaccurate information exists on the public hearing notice, then it must be revised and reissued.

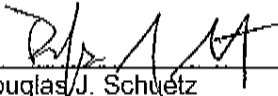
  
 \_\_\_\_\_  
 Douglas J. Schuetz  
 Acting Commissioner of Planning

cc: Supervisor Teresa Kenny, Orangetown  
 New York State Department of Transportation  
 Rockland County Drainage Agency  
 CSX Transportation, Inc.

Feerick Nugent MacCartney PLLC

Rockland County Planning Board Members

*\*NYS General Municipal Law Section 239 requires a vote of a 'majority plus one' of your agency to act contrary to the above findings. The review undertaken by the County of Rockland Department of Planning is pursuant to, and follows the mandates of Article 12-B of the New York General Municipal Law. Under Article 12-B the County of Rockland does not render opinions, nor does it make determinations, whether the item reviewed implicates the Religious Land Use and Institutionalized Persons Act. The County of Rockland Department of Planning defers to the municipality forwarding the item reviewed to render such opinions and make such determinations if appropriate under the circumstances.*

**110 WEST CROOKED HILL ROAD (O-2486)**

*In this respect, municipalities are advised that under the Religious Land Use and Institutionalized Persons Act, the preemptive force of any provision of the Act may be avoided (1) by changing a policy or practice that may result in a substantial burden on religious exercise, (2) by retaining a policy or practice and exempting the substantially burdened religious exercise, (3) by providing exemptions from a policy or practice for applications that substantially burden religious exercise, or (4) by any other means that eliminates the substantial burden.*

*Proponents of projects are advised to apply for variances, special permits or exceptions, hardship approval or other relief.*

*Pursuant to New York State General Municipal Law §239-m(6), the referring body shall file a report of final action it has taken with the County of Rockland Department of Planning within thirty (30) days after final action. A referring body which acts contrary to a recommendation of modification or disapproval of a proposed action shall set forth the reasons for the contrary action in such report.*



**Planning Board  
Town of Orangetown**

TO: Town Board

FROM: Planning Board

DATE: March 27, 2024

RE: **Referral- Proposed Local Law Amending Chapter 43, Section 2.2 to change the Zoning District of parcel known as 110 West Crooked Hill Road, Pearl River (68.11-3-37 & 38), from LIO to LI**

At the March 27, 2024 Planning Board Meeting, the Board reviewed the submitted Referral and had no comment. The Board made a motion to consent to the Town of Orangetown Town Board to be Lead Agency.

The motion was made by Michael Mandel, Vice Chairman and seconded by Kevin Farry and carried as follows: Thomas Warren – Chairman, aye; Denise Lenihan, aye; Michael Mandel, Vice Chairman, aye; Kevin Farry, aye; Michael McCrory, aye; Lisa DeFeciani, aye, Bruce Bond, (alternate member), not voting; and Andrew Andrews, aye.



Town of Orangetown Town Board

Date: March 8, 2024

Response to request that the Town of Orangetown Town Board be designated to serve as Lead Agency for the:

**RE: Referral / Proposed Local Law  
Amending Chapter 43, § 2.2 to Change the Zoning District of parcel know as  
110 West Crooked Hill Rd., Pearl River (68.11-3-37 & 38)  
From "LIO" to "LI"**

The Orangetown Planning Board agrees to the designation of the Town Board of the Town of Orangetown as lead agency for the above-referenced project.

\_\_\_\_\_  
Date

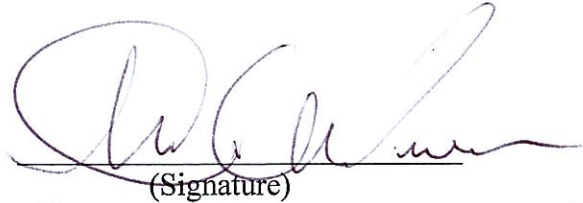
  
(Signature)

Thomas C. Warner Chairman  
(Print Name and Title)

Orangetown Planning Board  
(Name of Agency)

Encl.

March 27, 2024  
Other Business

**Town of Orangetown**

**Town Hall** 26 W. Orangeburg Road · Orangeburg NY, 10962

Telephone: (845) 359-5100 ext. 5004 · Fax: (845) 359-5126

e-mail: [tclerk@orangetown.com](mailto:tclerk@orangetown.com)

website: [www.orangetown.com](http://www.orangetown.com)



**March 8, 2024**

Rockland Cty Highway Dept. (USPS)  
Rockland Cty Dept of Planning (USPS)  
Orangetown Planning Board

**RE: Referral / Proposed Local Law  
Amending Chapter 43, § 2.2 to Change the Zoning District of parcel know as  
110 West Crooked Hill Rd., Pearl River (68.11-3-37 & 38)  
From "LIO" to "LI"**

Pursuant to General Municipal Law § § 239-1 & m, the Town Board of the Town of Orangetown, Rockland County, New York is hereby notifying you that, at its meeting held on March 5, 2024 the Town Board adopted resolutions in connection with the proposed action, to wit: amending Chapter 43, § 2.2 to Change the Zoning District of parcel know as 110 West Crooked Hill Rd., Pearl River (68.11-3-37 & 38), from "LIO" to "LI"; (i) declaring its intention to act as Lead Agency under SEQRA; (ii) making the preliminary determination that the proposed action is an "unlisted" action under SEQRA; (iii) directing that a SEQRA letter be circulated to the above named agencies for GML review, and to the Orangetown Planning Board for its review and recommendation under the Town Code.

The Town Board has determined that the action proposed is subject to review under the State Environmental Quality Review Act ("SEQRA"), and that such action constitutes an "unlisted" action. The Town Board, by Board Resolution, has expressed its intention to serve as Lead Agency for the action and, pursuant to Sections 617.6 (b) and (c) of the N.Y.C.R.R., and requests your agreement that it is designated.

The Town Board further wishes to expedite the designation of the Lead Agency and requests prompt reply. If you agree to the Town Board being designated Lead Agency, please sign this letter where indicated below and email ([tclerk@orangetown.com](mailto:tclerk@orangetown.com)) and/or fax (845) 359-5126 as soon as possible. If your agency does not submit a written objection within 30 days of the mailing of this notification, the Town Board will assume the role of lead agency for this action.

Enclosed please find a copy of the Petition and other relevant documents and information relating to the proposed action.

Thank you for your cooperation and courtesy.

Respectfully,

A handwritten signature in black ink, appearing to read "Rosanna Sfraga". The signature is fluid and cursive, with a large initial "R" and "S".

Rosanna Sfraga  
Town Clerk

Encl.

CC: Robert Magrino, Town Attorney (rmagrino@orangetown.com)

ROCKLAND COUNTY DEPARTMENT OF PLANNING  
REFERRAL FORM FOR GENERAL MUNICIPAL LAW REVIEWS

Municipality: TOWN OF ORANGETOWN

Date Sent: March 8, 2024

Board:  Town Board  Town/Village Public Hearing Date: April 2, 2024

File Name: Referral / Proposed Zone Change / Amending Chapter 43, § 2.2 to Change the Zoning District of parcel know as 110 West Crooked Hill Rd., Pearl River (68.11-3-37 & 38), from "LIO" to "LI"

Contact Person: Robert Magrino, Town Attorney  
Address 26 W Orangeburg Road, Orangeburg, New York 10962

Referral Agencies

(Please indicate the agencies that have also received copies of this application)

- RC Highway Department
- RC Division of Environmental Resources
- RC Drainage Agency
- RC Department of Environmental Health (Sewers, Water, Mosquito Code, Underground Tanks)
- RC Sewer District #1
- NYS Department of Environmental Conservation
- NYS Department of Transportation
- NYS Thruway Authority
- NY-NJ Trail Conference (Long Path)
- Palisades Interstate Park Commission
- US Army Corps of Engineers
- Cornell Cooperative Extension of Rockland County
- RC Department of Planning
- Adjacent Municipality:
- Other: Orangetown Planning Board

Pursuant to the General Municipal Law §§ 239-1 & m

Subdivision  Site Plan  Variance  Special Permit  Zone Change  
 Other – Please list: .

Location of Parcel(s): 110 W. Crooked Hill Rd., Pearl River, NY

Acreage of Parcel (s) Minimum Lot Acreage Proposed –

Existing Sq. Footage  Proposed Sq. Footage \_\_\_\_\_

The Property in Question Lies Within 500 Feet of: (Potential Development Sites)

- County Road  State Road, Thruway, or Parkway
- County Stream  State Park
- County Park  Village, Town, County, or State Boundary
- County or State Facility  The Long Path

*Donald Brenner, P.E., LL.B.*

*Attorney-At-Law • Professional Engineer  
4 Independence Avenue, Tappan, New York 10983*

RECEIVED

MAR 27 2024

Town of Orangetown  
Town Attorney's Office

*Phone 845-359-2210*

*Fax 845-359-8070*

March 26, 2024

Supervisor Teresa Kenny, Esq.  
Members of the Town Board  
Town of Orangetown  
26 West Orangeburg Road  
Orangeburg, New York 10962

Re: Petition for Verification of  
Zone Line on, Lot 1, Block 1, Section 65.15  
636 Greenbush Road, Blauvelt, New York 10913  
24-2605E

Dear Supervisor Kenny and Members of the Town Board:

My client Rathmagurry Realty Inc. is attempting to develop a parcel of land located at 636 Greenbush Road, Blauvelt. The Town Zoning Map shows that the parcel is divided into two Zoning designations (see Zone Line Confirmation Survey) prepared by Jay A. Greenwell, PLS, LLC dated February 22, 2024.

To properly develop the property it is necessary to finalize the location of the intended Zone Line.

Accordingly, I enclose (1) a Petition for Verification of the Zone Line and (2) Short Environmental Assessment Form.

The client respectfully requests that this matter be placed on the next Town Board Agenda for final consideration.

If you require additional information feel free to call me.

Very truly yours,



Donald Brenner

DB/hi

Enclosures

cc: Town Attorney  
Town Clerk  
Rathmagurry Realty, Inc.

TOWN BOARD: TOWN OF ORANGETOWN  
COUNTY OF ROCKLAND: STATE OF NEW YORK

-----X

Petition of

Rathmagurry Realty, Inc.

**PETITION FOR  
VERIFICATION  
OF ZONE LINE  
ON LOT 1**

Designate the Zone Line for Its Parcel Located at  
636 Greenbush Road, Blauvelt, New York, Designated  
on the Tax Map of the Town of Orangetown as  
Section 65.15, Block 1, Lot 1.

-----X

TO THE HONORABLE TOWN BOARD OF THE TOWN OF ORANGETOWN:

1. The Petitioner is the owner of the referenced parcel of land, which is located on the east side of NY Route 303, and the west side of Greenbush Road at the hamlet of Blauvelt.
  
2. The property described in Schedule "A" and designated on the Tax Map of the Town of Orangetown as:

<u>Section</u>	<u>Block</u>	<u>Lot</u>
65.15	1	1

Consists of 17.31 acres of real property.
  
3. The parcel is currently unimproved.
  
4. Although the parcel consists of a single tax lot, it is divided between two zoning districts. The easterly portion (about 58% of the parcel), lies in the "R-40" District and the westerly portion (about 42% of the parcel) lies in the "LO" District. *See* attached "Zoning Exhibit," Exhibit A, demonstrating the existing zoning district designations.
  
5. The Petitioner is in the process of seeking approvals from the Town to permit the use of a section of the Property for a proposed Self Storage Building. Specifically, the Applicant is proposing to construct a 120,000 sq. ft. Self Storage Building, on the "LO" portion of the

property.

6. The zoning district boundary line cuts directly through the Parcel, as demonstrated on the attached Exhibit A.

7. The surveyor of the property has examined prior submissions to the Town Planning Agencies, however the exact division was never established.

8. The Petition is unique. Accordingly, the Petition will attempt to use the criteria which is recommended for Zone Change.

(a) *Whether the uses permitted by the proposed change would be appropriate in the area concerned.*

The uses permitted in the area are consistent with areas developed on Route 303 and the Petitioner's property. There is no reason why a portion of the parcel should not be subject to the LO district's requirements, and the other portion subject to R-40 district's requirements, and it is not known why the district line has not been previously changed. Most of the land around the parcel (on the west side of Route 303) is zoned LIO and LI.

(b) *Whether adequate public school facilities and other public services exist or can be created to serve the needs of any additional residences likely to be constructed as a result of formalizing the location of the zone line.*

No public school facilities will be required. No additional residences are to be constructed, nor would any be permitted by the ratification of the zone line.

(c) *Whether the proposed change is in accord with any existing or proposed plans for providing public water supply and sanitary sewers in the vicinity.*

The proposed building use will be adequately served by the existing public water supply and sanitary sewer system.

*(d) The amount of vacant land which is currently zoned for this use is unavailable.*

The proposed change will not affect other parcels.

*(e) The effect of the proposed amendment upon the growth of existing communities in the Town as envisaged by the Comprehensive Plan.*

The split-zoning of the parcel hinders the Petitioner's ability to develop the parcel. The requirements for the parcel will be clear, and new tenants will in turn make the area more vibrant and further economic development in the Town.

*(f) Whether the proposed amendment is likely to result in an increase or decrease in the total zoned residential capacity of the Town and the probable effect of such a change on the cost of providing public services.*

The proposed change will have no impact on the total residential zoned capacity of the Town.

*(g) Whether other areas designed for similar development are likely to be so developed if the proposed amendment is adopted, and whether the designation for such future development should be withdrawn from such areas by further amendment of the Zoning Map.*

The proposed change is limited to a single tax lot and should have no impact on any other development in the Town.

9. For all the foregoing reasons, the Petitioner respectfully requests that the zoning line between the R-40 residential property on North Greenbush Road and the LO commercial property on Route 303 be properly established.



**WHEREFORE**, Petitioner respectfully requests that the Town Board of the Town of Orangetown establish the zoning line on the Zoning Map as set forth above.

Dated: Orangeburg, New York  
March 26, 2024

Respectfully submitted,

Rathmaggury Realty, Inc.

By: Brendan Cunney  
Brendan Cunney, Owner

*Helen M. Ingalls*

HELEN M. INGALLS  
NOTARY PUBLIC, STATE OF NEW YORK  
Registration No. 01IN6129380  
Qualified in Rockland County  
Commission Expires June 20, 2025

State of New York }  
County of Rockland }

On the 26<sup>th</sup> day of March the year 2024, before me, the undersigned, a notary public in and for said state, personally appeared Brendan Cunney, personally known to me or proved to me on the basis of satisfactory evidence to be the individual whose name(s) is (are) subscribed to the within instrument and acknowledged to me that he/she/they executed the same in his/her/their capacity(ies), and that by his/her/their signature(s) on the instrument, the individual(s), or the person upon behalf of which the individual(s) acted, executed the instrument.

## Schedule "A"

Tax Lot 65.15-1-1

BEGINNING at a rebar found on the easterly right of way of NYS Route 303, said iron pin marking the northwesterly corner of the lands described herein, and being formed by the intersection of the boundary line between the Town of Orangetown on the south and the Town of Clarkstown on the north, with said easterly right of way of NYS Route 303, and running thence:

1. Along said boundary line between the Town of Orangetown and the Town of Clarkstown, N 85°09'55" E distant 280.10 feet to an iron pipe; thence
2. Along the westerly right of way of Greenbush Road the following four courses and distances:
  - a. S 5°35'30" W distant 716.42 feet to a Rockland County Monument; thence
  - b. S 5°15'15" W distant 556.89 feet to a Rockland County Monument; thence
  - c. Southwesterly, on a curve to the right having a radius of 905.41 feet and an arc length of 156.04 feet to a Rockland County Monument; thence
  - d. S 15°07'45" W distant 347.81 feet; thence
3. Along the northerly line of lands n/f Arri Inc.(Tax Lot 65.19-1-1), N 71°15'00" W distant 694.10 feet to an iron rebar, and a non-tangent point on a curve; thence
4. Along the easterly right of way of NYS Route 303, the following three courses and distances:
  - a. Northeasterly, on a curve to the left having a radius of 1,698.11 feet and an arc length of 433.66 feet; thence
  - b. N 23°49'34" E distant 630.00 feet to a point of curvature; thence
  - c. Northeasterly, on a curve to the left having a radius of 1,678.80 feet and an arc length of 583.39 feet, back to the point or place of BEGINNING.

# EXHIBIT A



**JAMES J. DEAN**  
Superintendent of Highways  
Roadmaster IV

Orangetown Representative:  
R.C. Soil and Water Conservation Dist.-Chairman  
Stormwater Consortium of Rockland County  
Rockland County Water Quality Committee



**HIGHWAY DEPARTMENT**  
**TOWN OF ORANGETOWN**  
119 Route 303 • Orangeburg, NY 10962  
(845) 359-6500 • Fax (845) 359-6062  
E-Mail – [highwaydept@orangetown.com](mailto:highwaydept@orangetown.com)

Affiliations:  
American Public Works Association NY Metro Chapter  
NYS Association of Town Superintendents of Highways  
Hwy. Superintendents' Association of Rockland County

## MEMORANDUM

**DATE:** March 28, 2024

**TO:** Allison Kardon, Confidential Assistant to Town Supervisor

**FROM:** James J. Dean, Superintendent of Highways 

**RE:** **Change Order #1– Villa Drive Culvert Pipe Replacement Project**

---

Due to unforeseen conditions and unsuitable materials within the Villa Drive Culvert Pipe Replacement Project, approve Change Order #1 in the amount of \$94,460 to remove unsuitable material and replace with stable material.

Please place the following item on the April 2, 2024 Regular Town Board Meeting Agenda:

**APPROVE/ CHANGE ORDER #1/ VAD CONSTRUCTION CORP./ VILLA DRIVE CULVERT PIPE REPLACEMENT PROJECT**

**RESOLVED**, upon the recommendation of the Superintendent of Highways, and Commissioner of the Department of Environmental Management and Engineering, the Town Board hereby approves VAD Construction Corp. Change Order #1, in the amount of \$94,460 to remove unsuitable material and replace with stable material for the Villa Drive Culvert Pipe Replacement Project.





# CHANGE ORDER NO. 1

## CONTRACT NO.

Date: March 26, 2024

<b>Owner:</b>	<b>Town of Orangetown Highway Department 119 Route 303 Orangeburg, NY 10962</b>	<b>Contractor:</b>	<b>VAD Construction, Corp. White Plains, NY</b>
---------------	---	--------------------	---

<b>Project:</b>	<b>Villa Drive Culvert Pipe Replacement Project</b>
-----------------	---

<b>Contract No.:</b>		<b>Government Project No.:</b>	
----------------------	--	--------------------------------	--

The contractor is hereby authorized and directed to make the changes described below, and agrees to furnish all labor, materials, and equipment to accomplish the changes in accordance with the applicable portions of the Contract Documents for this project.

**Description of Change (Including Location and Reasons Therefore):**

See attached "Description of Change Summary."

**Enclosures and References:**

In executing this change order, it is mutually agreed that the amounts provided for herein will be accepted by the contractor as full compensation for all known costs associated in the work, including all direct and indirect costs, and any and all known costs associated with delays or additional time, if any, which may be required as a result of said changes.

	AMOUNT		Contract Time
Original Contract Price	\$292,486.00	Substantial Completion Date Prior to Change Order	
Contract Price Prior to Change Order	\$292,486.00	Final Payment Date Prior To Change Order	
Net Amount This Change Order	\$94,460.00	Net Time This Change Order	-
Revised Contract Price	\$386,946.00		

OWNER		CONTRACTOR	
Approved:		Approved:	
Title:		Title:	
Date:		Date:	
Telephone:		Telephone:	

**Remarks:**

1. The party initiating the change order request is the Town of Orangetown.
2. Does this change order:
  - a. Affect the work of other contractors? No
  - b. Require additional work by other contractors? No
  - c. Constitute entire cost of the change? (If not, explain.) – Yes



---

**CHANGE ORDER NO. 1**  
**CONTRACT NO.**

---

**Description of Change Summary:**

<b>1. \$36,425.00</b>	<b>Saturated and Unusable Soil Removal and Disposal</b>
<b>2. \$40,625.00</b>	<b>Additional Embankment Materials</b>
<b>3. \$14,160.00</b>	<b>Additional Select Granular Fill</b>
<b>4. \$6,250.00</b>	<b>House Leader Connection to New 36" Culvert Pipe</b>
<b>5. <u>(\$3,000.00)</u></b>	<b>Credit toward Contract Item 603.7309-Flared End Section</b>
<b><u>\$94,460.00</u></b>	<b>Total Change Order Cost</b>

**JAMES J. DEAN**  
Superintendent of Highways  
Roadmaster IV

Orangetown Representative:

R.C. Soil and Water Conservation Dist.-Chairman  
Stormwater Consortium of Rockland County  
Rockland County Water Quality Committee



**HIGHWAY DEPARTMENT**  
**TOWN OF ORANGETOWN**  
119 Route 303 • Orangeburg, NY 10962  
(845) 359-6500 • Fax (845) 359-6062  
E-Mail – [highwaydept@orangetown.com](mailto:highwaydept@orangetown.com)

Affiliations:

American Public Works Association NY Metro Chapter  
NYS Association of Town Superintendents of Highways  
Hwy. Superintendents' Association of Rockland County

## MEMORANDUM

**DATE:** April 2, 2024

**TO:** Teresa Kenny, Supervisor  
Jerry Bottari, Councilman  
Brian Donohue, Councilman  
Dan Sullivan, Councilman  
Paul Valentine, Councilman

**CC:** Jeffrey Bencik, Finance Director  
Allison Kardon, Confidential Assistant to Town Supervisor  
Eamon Reilly, P.E., Commissioner, DEME

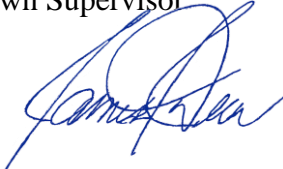
**FROM:** James J. Dean, Superintendent of Highways 

**RE:** **Change Order #1– Villa Drive Culvert Pipe Replacement Project**

---

Please accept this memorandum as an explanation for the five (5) Contract Change Order Items, totaling \$94,460.00, for the Villa Drive Culvert Pipe Replacement Project.

Please be advised that unforeseen site conditions have created unavoidable project scope changes which then incurred undisputable contractual cost increases.

Below please find the Contract Change Orders with an explanation for each:

**Change Order Item 1.      \$36,425.00 – Unusable Soil Excavation and Disposal.**  
During the removal of the existing culvert pipe, the contractor discovered the soil excavated around the pipe as well as the soil in the near vicinity of the pipe was saturated silt, clay and mud and had to be removed, not only from the trench but transported off site. This soil had to be excavated and disposed of as it was not suitable to be re-used as a stable foundation or backfill material for the new culvert pipe.

**Change Order Item 2.      \$40,625.00 – Additional Embankment Materials.**

HAMLETS: PEARL RIVER · BLAUVELT · SOUTH NYACK · UPPER GRANDVIEW · ORANGEBURG · TAPPAN · SPARKILL · PALISADES



CLEAN STREETS = CLEAN STREAMS



**JAMES J. DEAN**  
Superintendent of Highways  
Roadmaster IV

Orangetown Representative:

R.C. Soil and Water Conservation Dist.-Chairman  
Stormwater Consortium of Rockland County  
Rockland County Water Quality Committee



**HIGHWAY DEPARTMENT  
TOWN OF ORANGETOWN**

119 Route 303 • Orangeburg, NY 10962  
(845) 359-6500 • Fax (845) 359-6062  
E-Mail – [highwaydept@orangetown.com](mailto:highwaydept@orangetown.com)

Affiliations:

American Public Works Association NY Metro Chapter  
NYS Association of Town Superintendents of Highways  
Hwy. Superintendents' Association of Rockland County

As the excavated soil was of greater volume than had been anticipated in the original scope of work, the contractor was forced to use Three Hundred Twenty-Five (325) Cubic Yards of “Item 4” embankment material to replace the unsuitable material removed from site. The “Item 4” embankment material was used as backfill and provided a stable, porous, embankment material that would protect the pipe and prevent the yard and driveway from sinking over time.

**Change Order Item 3.**

**\$14,160.00 – Additional Select Granular Fill.**

As the excavated soil was of greater volume than had been anticipated in the original scope of work, the contractor was forced to use One Hundred Eighteen (118) Cubic Yards of additional ¾” crushed stone as stable foundation material for the new culvert pipe.

**Change Order Item 4.**

**\$6,250.00 – House Leader Connection to New 36” Culvert Pipe.**

The Superintendent of Highways and Commissioner of DEME recommended the connection the house leader drains to the new 36” culvert pipe in order to mitigate water flow around the end section.

**Change Order Item 5.**

**\$3,000.00 – Credit for Contract Item 603.7309 Substitution**

The Superintendent of Highways and Commissioner of DEME allowed for the substitution of Item 603.7309 (concrete Flared End Inlet Section) with an HDPE Flared End Inlet Section as the concrete flared end section could not be delivered in a timely manner.

Should you have any questions or need additional information regarding this change order approval please feel free to contact Eamon Reilly or myself.

JJD/sfm

Attachments





# CHANGE ORDER NO. 1

## CONTRACT NO.

Date: March 26, 2024

<b>Owner:</b>	Town of Orangetown Highway Department 119 Route 303 Orangeburg, NY 10962	<b>Contractor:</b>	VAD Construction, Corp. White Plains, NY
---------------	---	--------------------	--

<b>Project:</b>	Villa Drive Culvert Pipe Replacement Project
-----------------	--

<b>Contract No.:</b>		<b>Government Project No.:</b>	
----------------------	--	--------------------------------	--

The contractor is hereby authorized and directed to make the changes described below, and agrees to furnish all labor, materials, and equipment to accomplish the changes in accordance with the applicable portions of the Contract Documents for this project.

**Description of Change (Including Location and Reasons Therefore):**

See attached "Description of Change Summary."

**Enclosures and References:**

In executing this change order, it is mutually agreed that the amounts provided for herein will be accepted by the contractor as full compensation for all known costs associated in the work, including all direct and indirect costs, and any and all known costs associated with delays or additional time, if any, which may be required as a result of said changes.

	AMOUNT		Contract Time
Original Contract Price	\$292,486.00	Substantial Completion Date Prior to Change Order	
Contract Price Prior to Change Order	\$292,486.00	Final Payment Date Prior To Change Order	
Net Amount This Change Order	\$94,460.00	Net Time This Change Order	-
Revised Contract Price	\$386,946.00		

OWNER		CONTRACTOR	
Approved:		Approved:	
Title:		Title:	President
Date:		Date:	4/1/2024
Telephone:		Telephone:	(914) 369-1508

**Remarks:**

1. The party initiating the change order request is the Town of Orangetown.
2. Does this change order:
  - a. Affect the work of other contractors? No
  - b. Require additional work by other contractors? No
  - c. Constitute entire cost of the change? (If not, explain.) – Yes



---

**CHANGE ORDER NO. 1**  
**CONTRACT NO.**

---

**Description of Change Summary:**

- |                               |  |
|-------------------------------|--|
| <b>1. \$36,425.00</b>         | <b>Unusable Soil Removal and Disposal</b>              |
| <b>2. \$40,625.00</b>         | <b>Additional Embankment Materials</b>                 |
| <b>3. \$14,160.00</b>         | <b>Additional Select Granular Fill</b>                 |
| <b>4. \$6,250.00</b>          | <b>House Leader Connection to New 36" Culvert Pipe</b> |
| <b>5. <u>(\$3,000.00)</u></b> | <b>Credit for Contract Item 603.7309 Substitution</b>  |
| <b><u>\$94,460.00</u></b>     | <b>Total Change Order Cost</b>                         |



**LIST OF DRAWINGS**

ARCHITECTURAL DRAWINGS	SHEET DESCRIPTION
A-0	SITE LOCATION PLAN
A-1	PROPOSED PLANS AND ELEVATIONS
A-2	TYPICAL SECTION
A-3	SPECIFICATIONS

**SITE PLAN**



It is a violation of the law for any person, unless acting under the direction of a licensed architect, to alter an item in any way, if an item bearing the seal of an architect is altered, the altering architect shall affix to his item the seal and his profession. Altered by following by his signature and the date of such alteration, and a specific description of the alteration.

159 East Central Avenue  
 Pearl River, New York 10965  
 (845) 732-9762 karl@ackermann.com  
 Residential & Commercial Architecture and Green Design  
 New York & New Jersey Licensed Architect

**Karl E. Ackermann, AIA Architect PLLC**  
 Architect

NYS LIC. 027393 - Registered through Date April 30, 2026  
 NJ LIC. 27A01684200 - Registered through Date July 31, 2025 © Copyright 2024



Proposed New Snack Shed For  
**O'Grady's Castle**  
 at **Blue Hill Golf Course**  
 285 Blue Hill Rd., Pearl River, NY 10965  
 SBL - 8

Issue Date:	3/25/24
Revisions	
1	4/1/24 Permit
2	
3	
4	

Sheet No.  
**A-0**

# DESIGN CRITERIA

## List of applicable State Codes, Reference Codes and Standards:

- 2020 Building Code of New York State
- 2020 Fire Code of New York State
- 2020 Property Maintenance Code of New York State
- 2020 Mechanical Code of New York State
- 2020 Plumbing Code of New York State
- 2020 Fuel Gas Code of New York State
- NFPA 70 (National Electrical Code)
- 2017 National Electrical Code

CLASSIFICATION OF WORK  
? - ACCESSORY USE

### GENERAL NOTE: (SEE SPECIFICATIONS)

1. All work and materials shall conform to all local, county and New York State 2020 Codes.
2. Contractor to consider all dimensions approximate pending field verification, prior to construction, consult architect as required.
3. Contractor to furnish and provide all labor materials and equipment required to fully complete the job as shown on these documents. Except where specifically agreed on by owner, job shall be ready for occupancy in a good workmanship manner with all work done as shown or reasonable intended on documents. It shall include but not limited to:
  - A. Building permit
  - B. Certificate of Insurance
  - C. Demolition as required
  - D. Excavation
  - E. Masonry
  - F. Carpentry
  - G. Painting and Finishing
  - H. Trim work
  - I. Caulking/Sealant
4. Contractor shall furnish and install exterior paint as specified.
5. All materials shall be installed in strict accordance with manufacturers specifications.
6. See specifications for additional notes & information

It is a violation of the law for any person, unless acting under the direction of a licensed architect, to alter an item in any way if an item bearing the seal of an architect is altered, the altering architect shall affix to his item the seal and professional signature followed by his signature and the date of such alteration, and a graphic description of the alteration.

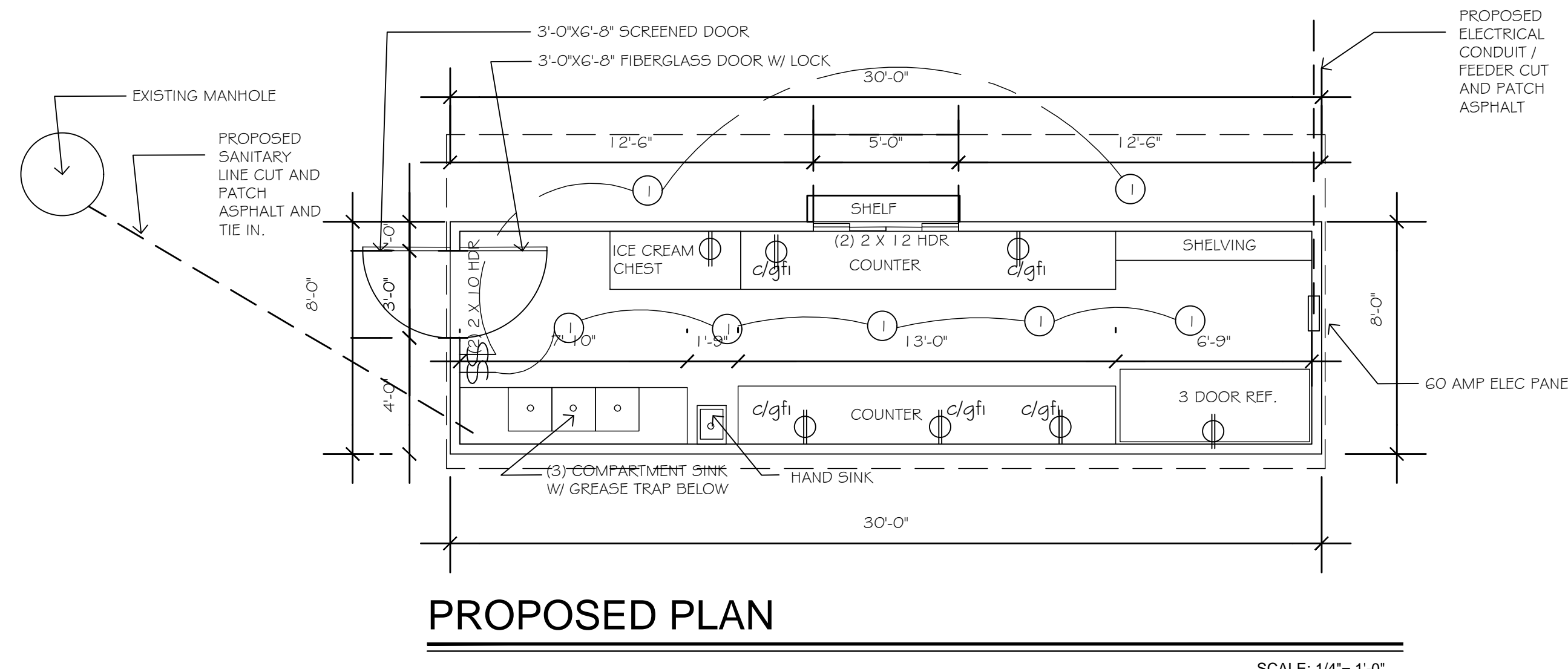
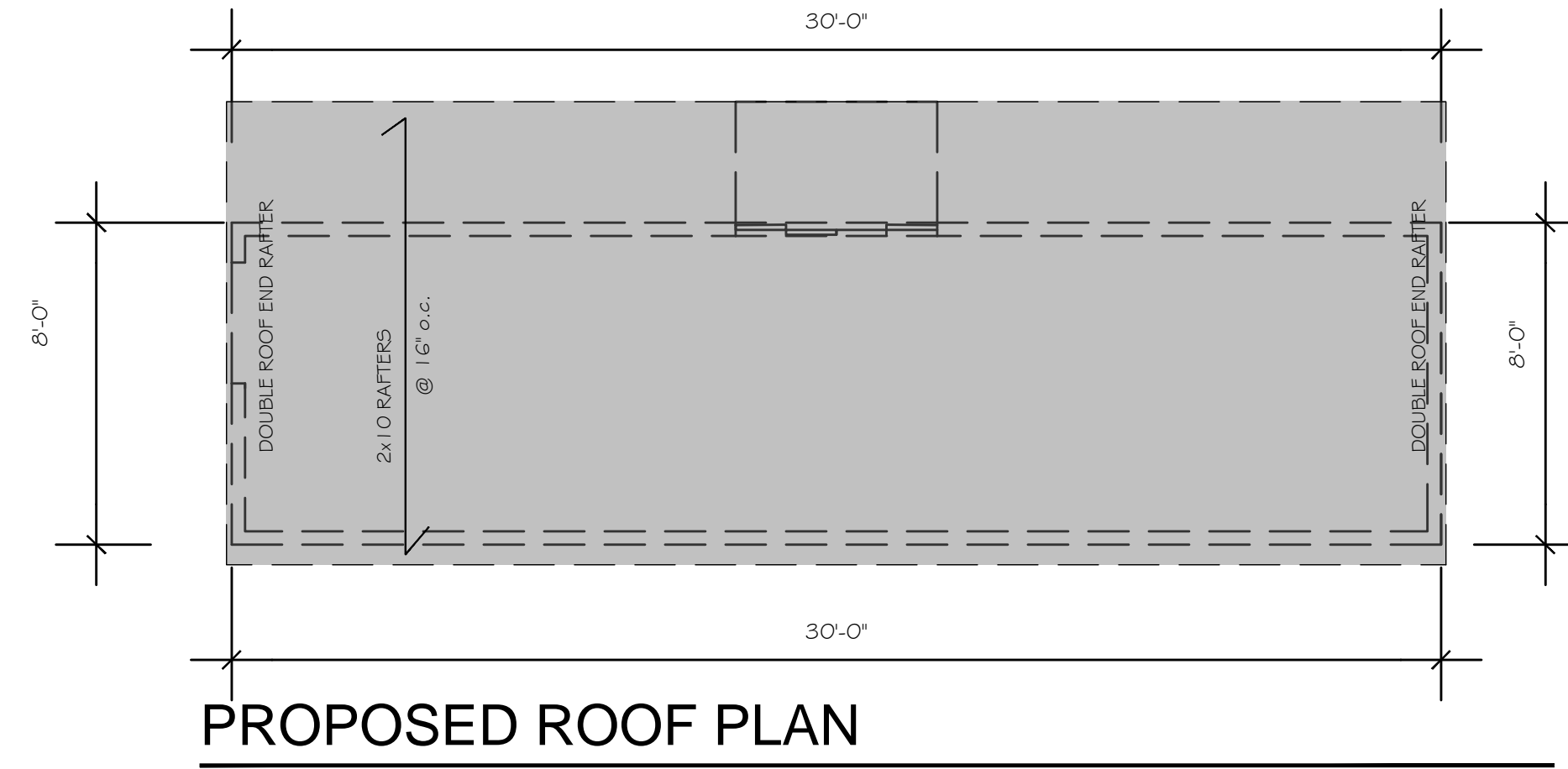

Electrical Fixture Schedule	
NOTE: FINAL LOCATION OF ALL FIXTURES TO BE LOCATED IN FIELD WITH OWNER. NOTE: ALL OUTLETS, PHONE AND CABLE JACKS TO BE MOUNTED 18" A.F.F. UNLESS NOTED NOTE: ALL SWITCHES AND OUTLETS AT COUNTERS. (1-1/2) 1/8" A.F.F.	
Symbol	Fixture Type
Ⓛ	5' RECESSED WET RATED LED DOWNLIGHT IC RATED LIGHTS MUST BE USED IN CONTACT WITH INSULATION PROVIDE SEALED FIXTURE OR - 4 GANG BACK BOX REQUIRED
Ⓢ	WALL SWITCH
Ⓜ	DUPLEX RECEPTACLE
Ⓜ <sup>c</sup>	COUNTERTOP HT. DUPLEX RECEPTACLE
Ⓜ <sup>GFI</sup>	GROUND FAULT INTERRUPTER SEE PLANS FOR HEIGHT

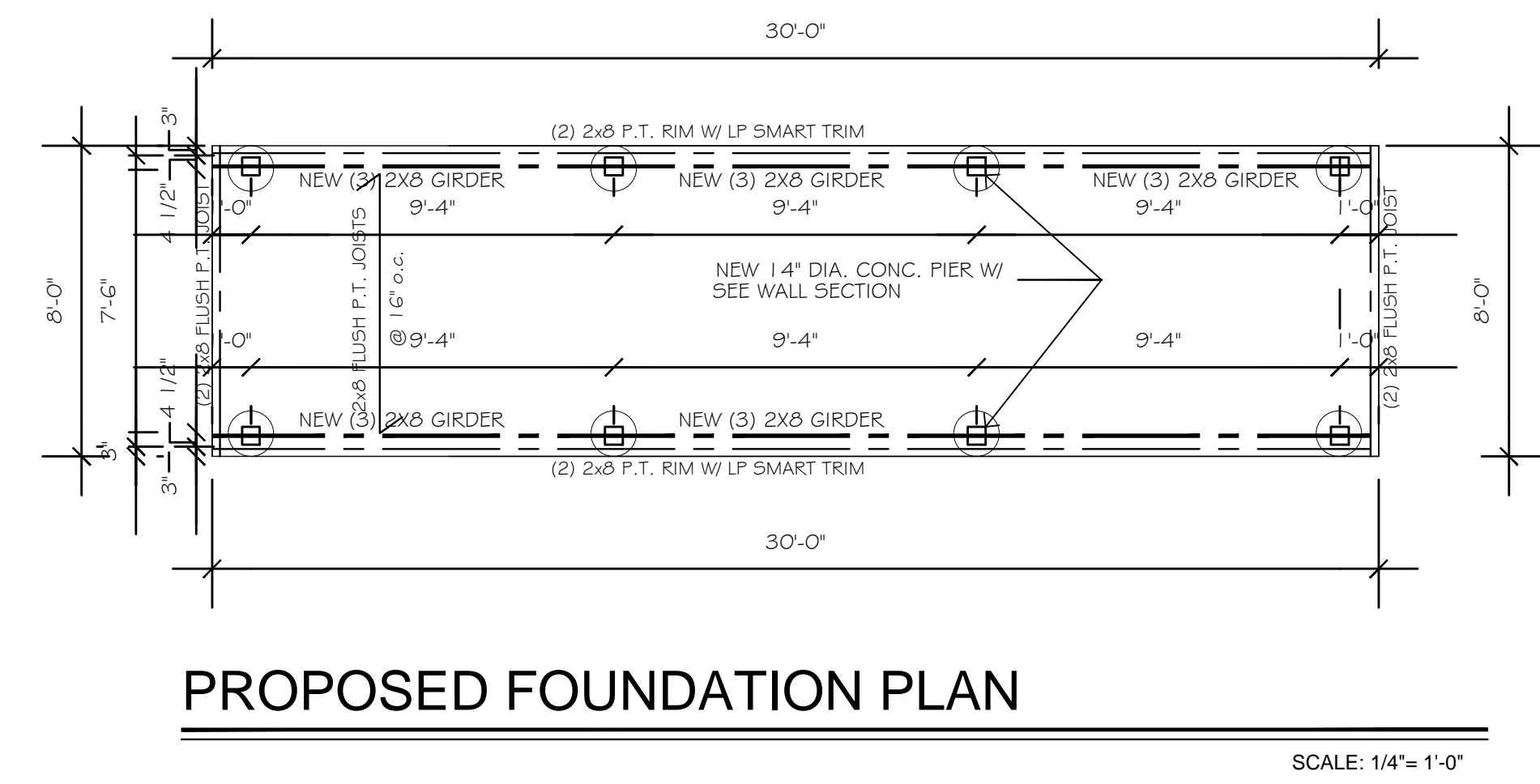

**Karl E. Ackermann, AIA Architect PLLC**  
Architect

159 East Central Avenue  
Pearl River, New York 10965  
(845) 732-3752 karl@karl-ackermann.com

Residential & Commercial Architecture and Green Design  
New York & New Jersey Licensed Architect

NYS LIC. 027393 - Registered through Date April 30, 2026  
NJ LIC. 21A01684200 - Registered through Date July 31, 2025

© Copyright 2024

Proposed New Snack Shed For  
**O'Grady's Castle**  
at **Blue Hill Golf Course**  
285 Blue Hill Rd., Pearl River, NY 10965  
SBL - 8

Issue Date:	3/25/24
Revisions	
1	4/1/24 Permit
2	
3	
4	

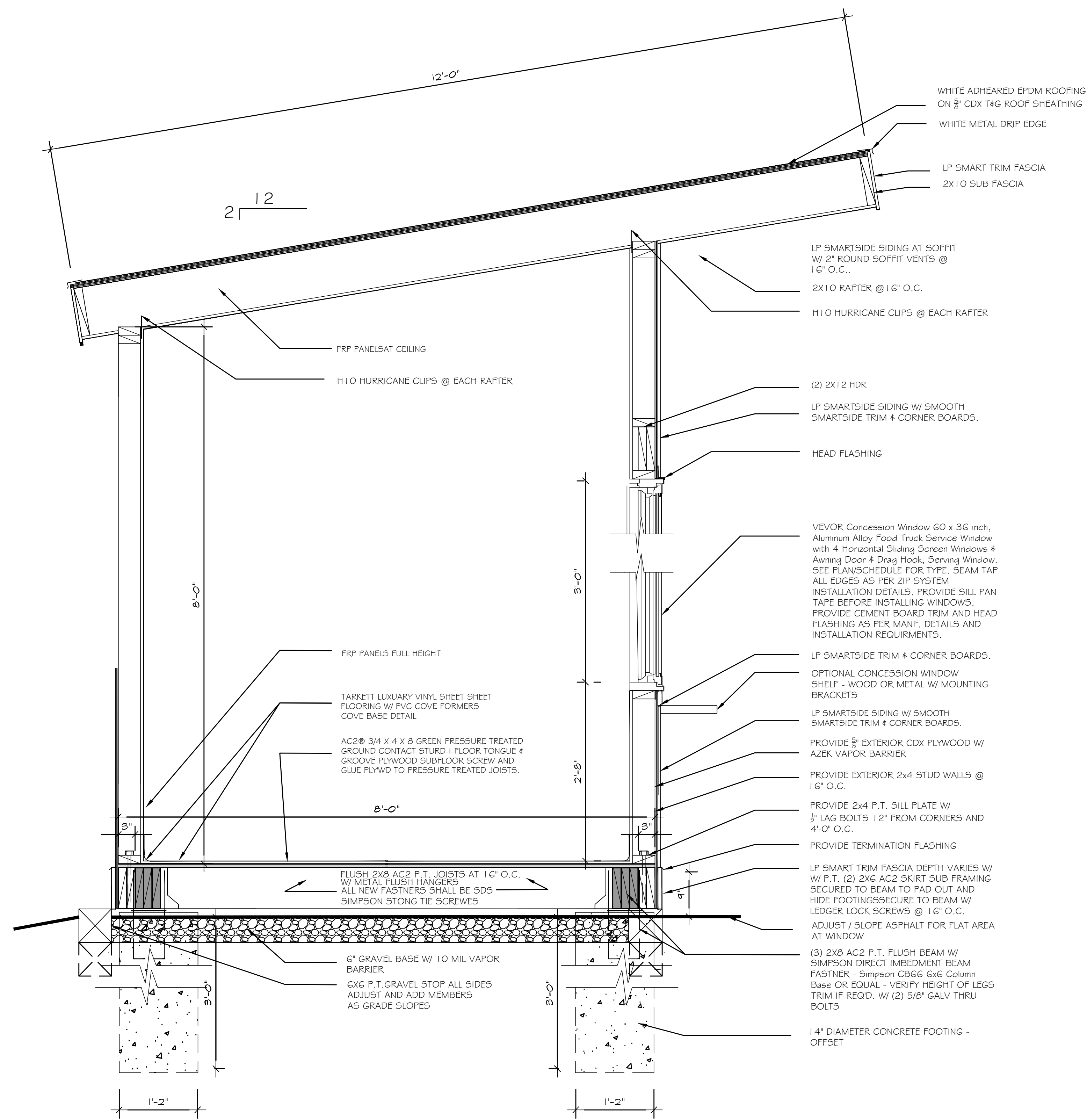

1 BUILDING SECTION

SCALE: 1" = 1'-0"

It is a violation of the law for any person, unless acting under the direction of a licensed architect, to alter an item in any way if an item bearing the seal of an architect is altered, the altering architect shall affix to his item the seal and his signature. Altered by followed by his signature and the date of such alteration, and a specific description of the alteration.

159 East Central Avenue  
 Pearl River, New York 10965  
 (845) 732-3762 karack@verizon.net  
 Residential & Commercial Architecture and Green Design  
 New York & New Jersey Licensed Architect

Karl E. Ackermann, AIA Architect PLLC  
 Architect

NYS LIC. 027393 - Registered through Date April 30, 2026  
 NJ LIC. 21A01684200 - Registered through Date July 31, 2025

Proposed New Snack Shed For  
 O'Grady's Castle  
 at Blue Hill Golf Course  
 285 Blue Hill Rd., Pearl River, NY 10965  
 SBL - 8

Issue Date:	3/25/24
Revisions	
1	4/1/24 Permit
2	
3	
4	

Sheet No.  
**A-2**

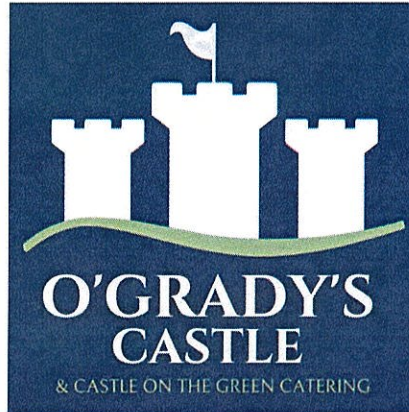

## Proposal for O'Grady's Castle Snack Shed at Blue Hill Golf Course

### Plan:

Tear down the existing 20'x 6.5' red wood structure and scoreboard and replace with a new construction 30'x8' snack shop.

See drawing and example pics attached

### Construction:

6x6 pressure treated railroad ties and gravel foundation

Framing 2x8 Pressure Treated Lumber for Floor covered with  $\frac{3}{4}$ ' pressure treated plywood.

Interior Flooring will be linoleum with rubber base moulding for easy mopping

Framing would be 2x4 pressure treated with vinyl siding on exterior. Asphalt shingle slanted roof.

Exterior Door with Screen on one end of the building, 60"x36" Concession window with screen

Interior wall surface would be FRP wall board for easy cleaning

### Electrical:

Smith Electric would be contracted to do the work which would include

Run 670 amps from Pro Shop panel in 1/14 pvc conduit underground

Run Pipe to 16 circuit electrical panel

Install 6 dedicated GFI's for kitchen equipment

Provide 2 8 foot strip led fixtures on single pole switch



Install 2 spot lights on exterior single pole switch

Handle electrical inspections

Plumbing:

Smith Plumbing and Heating would be contracted to do the work which would include

Tapping into the water source from the pro shop or the existing hot box on the course

Running all piping necessary

Running all waste into the sewer access located a few feet from the location of the shed

Installing a 12 gallon hot water heater

Installing a 3 basin corner sink with 2 drain boards and 1 air gap

Installing 1 hand washing sink

Installing a grease trap if deemed necessary dependant on town code (tbd)

Proposed Menu would Include

Chips, Candy and Pre Packaged Snacks

Ice Cream – prepackaged items

Coffee and Hot Chocolate

Premade Sandwiches/Salads/Wraps/Bagels/ etc – prepared and packaged across the parking lot  
at O’Grady’s Castle and transported to the shack for sale out of the refrigerated coolers

Canned and Bottled Beverages

Hot Dogs and other items like sausage and peppers or meatball sandwiches that can be kept to  
temperature in table top plug in steam table unit

Hot Pretzels

Estimated Cost \$40,000 to \$60,000

O’Grady’s Castle

285 Blue Hill Road

Pearl River NY 10965

Michelle Worob – 914-261-8250 ogradycastle@gmail.com



Example 1c

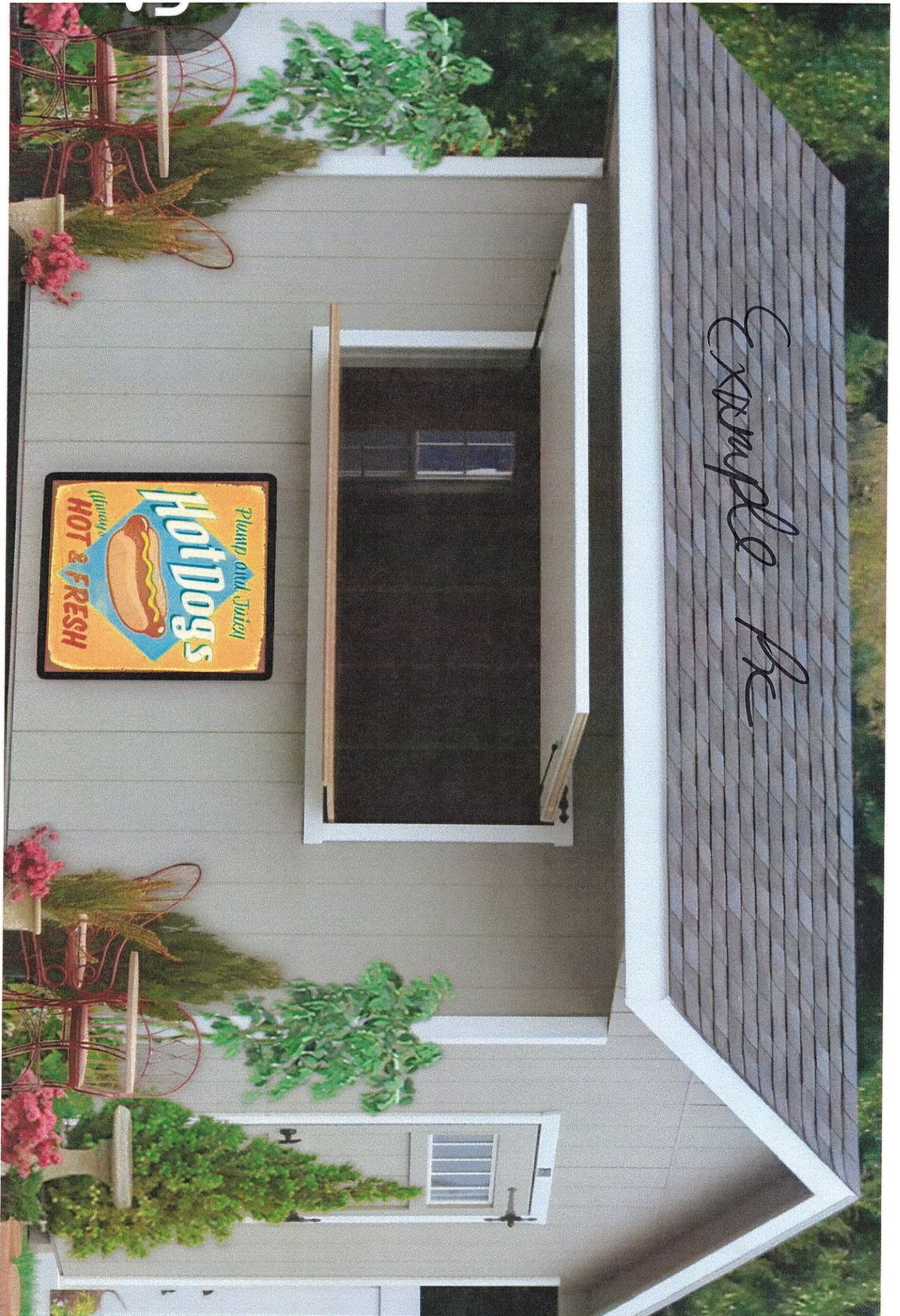

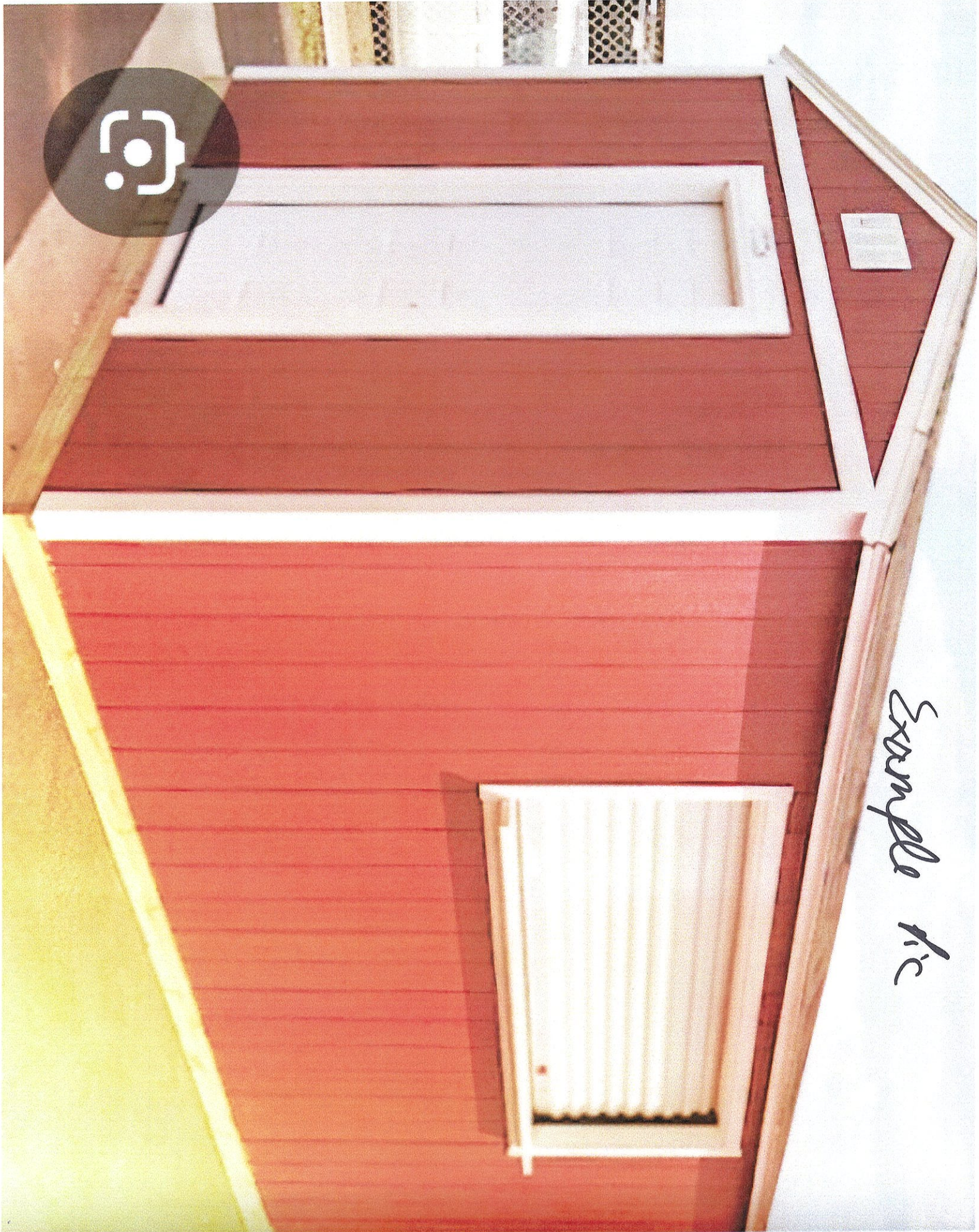

*Example de*

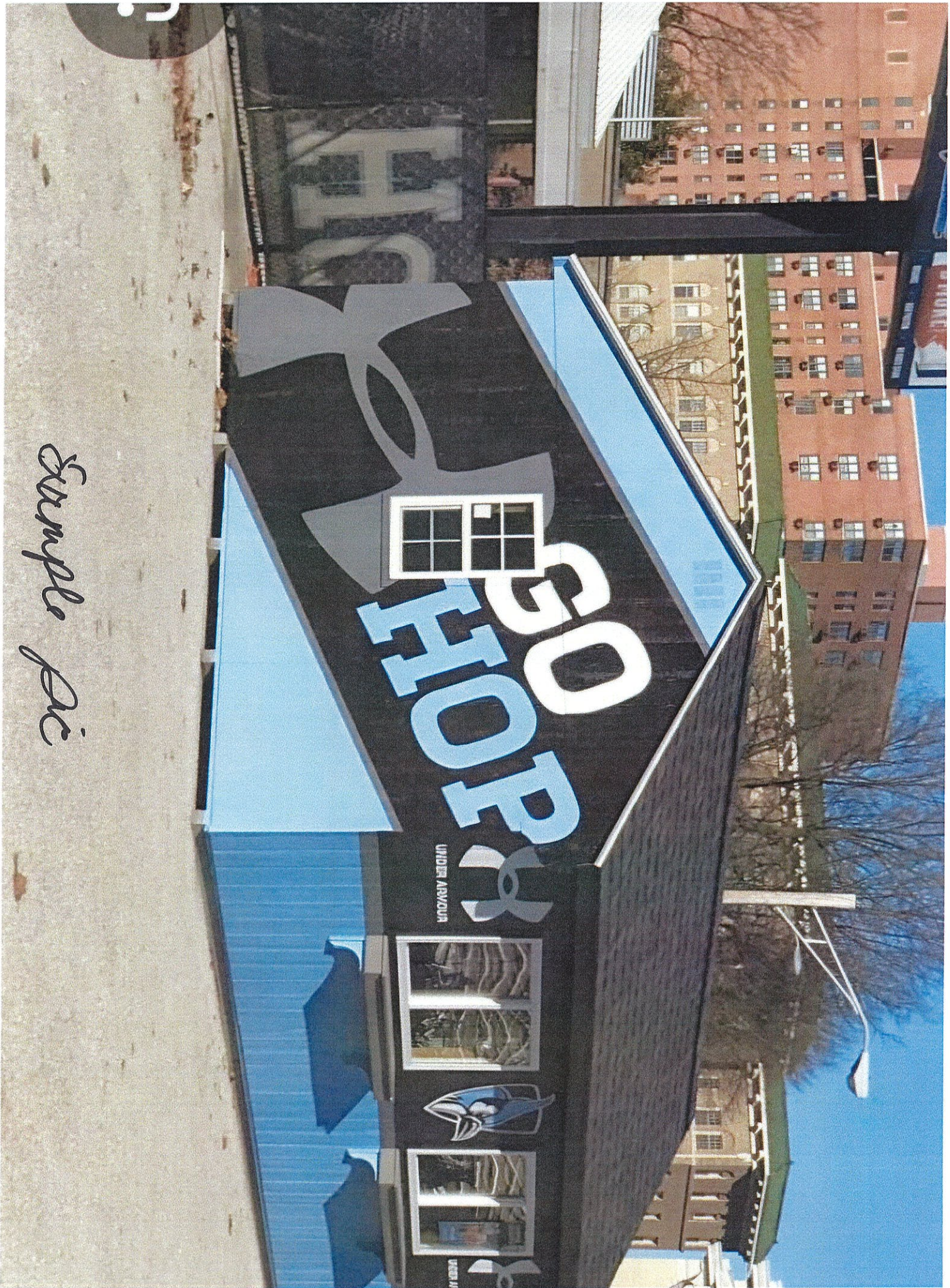

*Sample Pic*

*Existing structure  
to be removed*

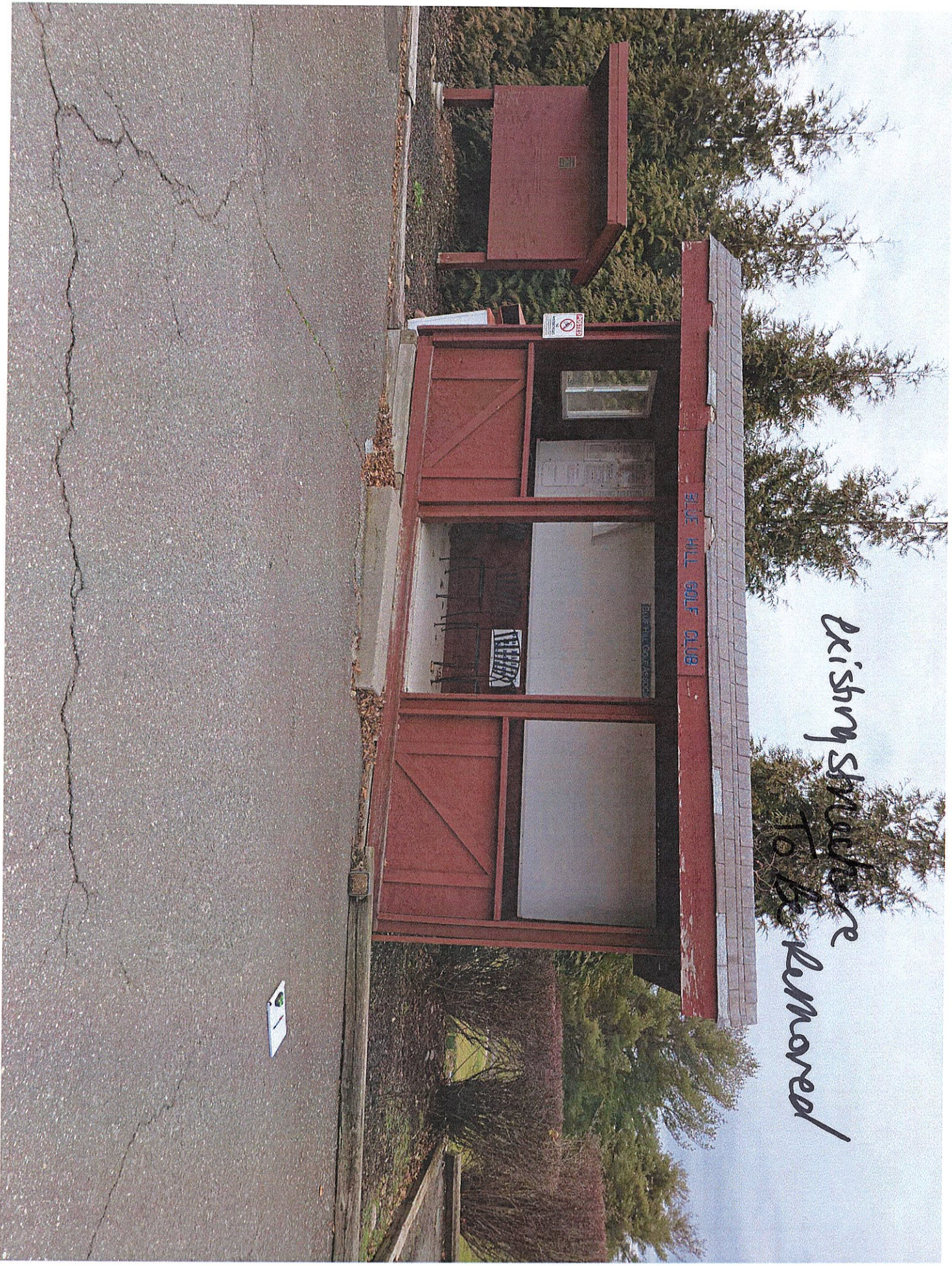









## Regency 44 1/2" 16 Gauge Stainless Steel Three Compartment Commercial Corner Sink with Two Drainboards - 14" x 14" x 14" Bowls

#600S3141414XC



### Technical Data

Length	44 1/2 Inches
Width	19 1/2 Inches
Height	43 3/4 Inches
Drainboard Length	14 Inches
Bowl Depth	14 Inches
Basket Drain Size	3 1/2 Inches
Bowl Front to Back	14 Inches
Bowl Left to Right	14 Inches
Faucet Centers	8 Inches
Features	NSF Listed

### Features

- Made of high-quality 16 gauge, type 304 stainless steel
- Corner design for maximum space-efficiency; legs feature H-shape cross braces to provide ample structural support
- Stainless steel legs, sockets, and bullet feet for maximum strength and longevity
- Includes 1 1/2" IPS drain connection and 3 1/2" basket strainers
- Two sets of faucet holes pre-punched on 8" centers (faucet sold separately)

### Certifications



## Technical Data

Gauge	16 Gauge
Leg Construction	Stainless Steel
Material	Stainless Steel
Number of Compartments	3 Compartments
Number of Drainboards	2 Drainboards
Stainless Steel Type	Type 304
Style	2 Drainboards
Type	Corner Sinks

## Plan View

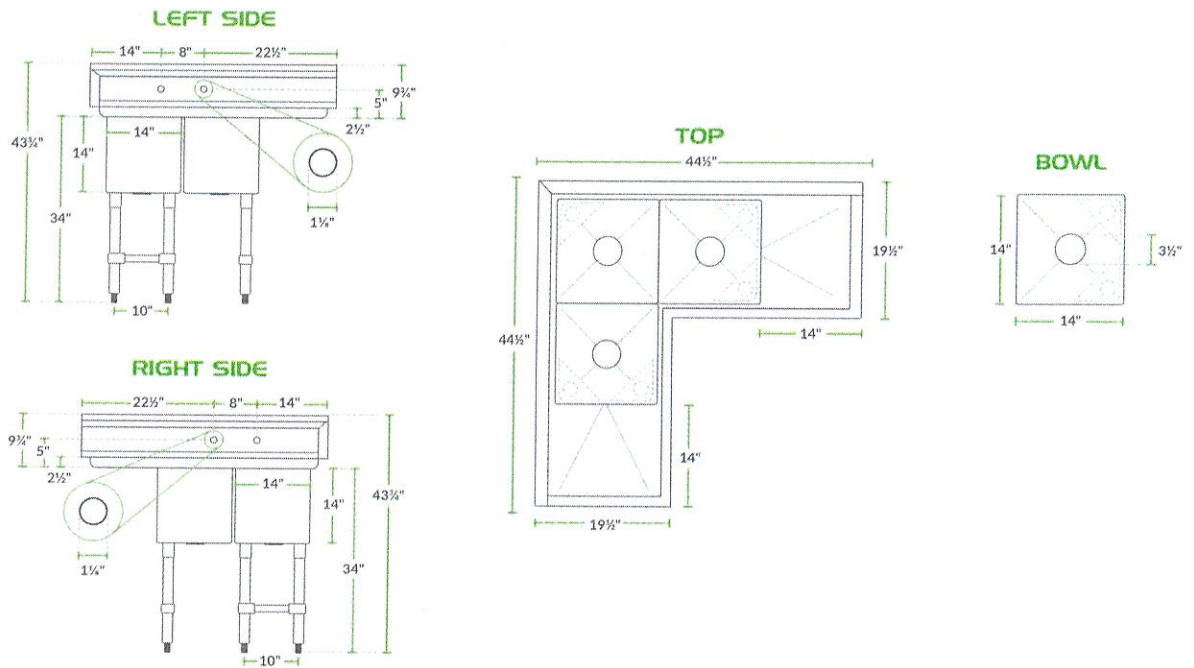

## Notes & Details

Outfit your facility with a long-lasting sink with this Regency three compartment stainless steel corner sink with two drainboards. Featuring three compartments, the sink is perfect for dishwashing applications, with one 14" x 14" x 14" sink for each of the three stages of the washing process. Plus, the corner design helps maximize your back-of-house space and create an efficient layout. One left 14" and one right 14" drainboard are built into the unit for added convenience.

Made of durable 16 gauge, 304 type stainless steel, the sink is sure to withstand constant use in a bustling commercial environment. The metal won't rust or corrode, nor will the stainless steel legs, sockets, or bullet feet. For added structural strength, the legs include H-shape cross braces; these ensure that all parts of the corner unit are properly supported at all times.

Faucet holes are punched into the metal on 8" centers to accept a splash mount faucet (sold separately), and a 3 1/2" drain basket is included for easy cleaning.

**⚠ WARNING:** This product can expose you to chemicals including Lead and Nickel, which are known to the State of California to cause cancer, birth defects, or other reproductive harm. For more information, go to [www.p65warnings.ca.gov](http://www.p65warnings.ca.gov)

**REGENCY**  
Tables and Sinks

**Regency 12" x 16" Wall Mounted Hand Sink with Gooseneck Faucet and Side Splash**

#600HS12SP

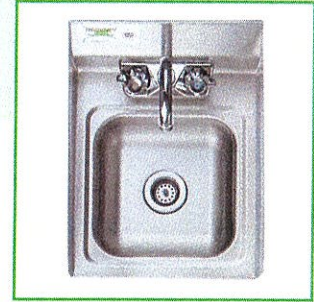
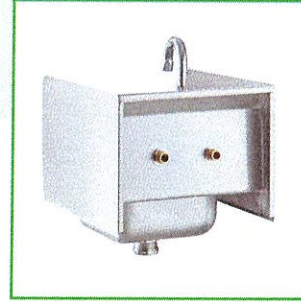

**Technical Data**

Length	12 Inches
Width	16 Inches
Height	12 Inches
Bowl Depth	4 Inches
Faucet Height	8 Inches
Bowl Front to Back	9 Inches
Bowl Left to Right	9 Inches
Faucet Centers	4 Inches
Flow Rate	2 GPM
Gauge	20 Gauge

**Features**

- 8" gooseneck faucet included
- 18-gauge type 304 stainless steel side splashes and a wall mounted clip
- 20-gauge type 304 stainless steel
- Holes punched on 4" centers; 8" backsplash
- Single 9" x 9" x 4" bowl includes 1 1/2" IPS drain baskets

**Certifications**



## Technical Data

Features	Faucet Included Massachusetts Accepted Plumbing Product NSF Listed Side Splashes
Installation Type	Wall Mounted
Material	Stainless Steel
Number of Compartments	1 Compartment
Number of Faucets	1 Faucets
Spout Type	Gooseneck
Stainless Steel Type	Type 304
Type	Hand Sinks

## Plan View

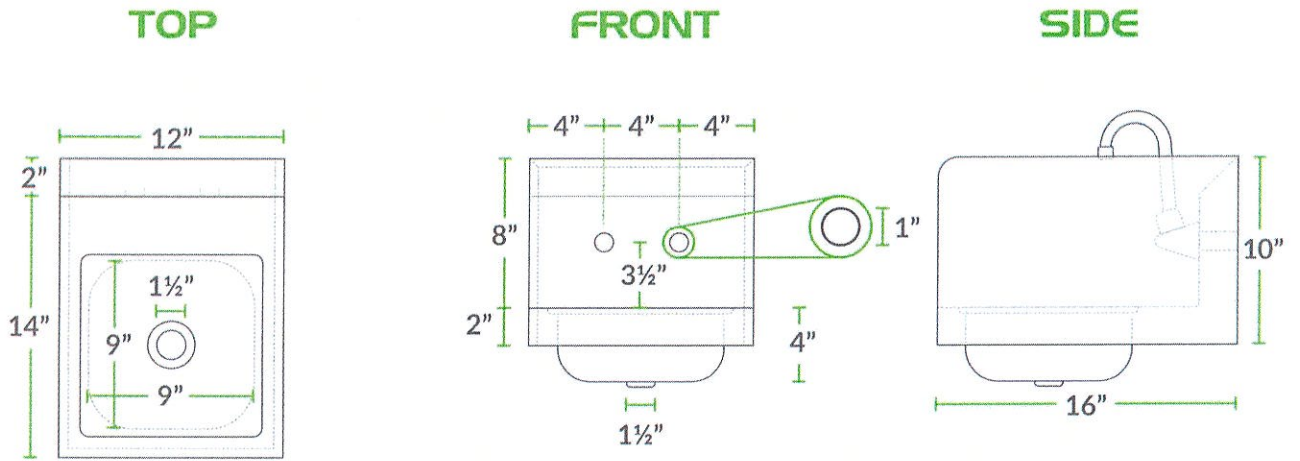

## Notes & Details

Keep your restaurant up to code without sacrificing space with this Regency HS-12-SP space saver hand sink with side splash. Each sink comes standard with a single 9" x 9" x 4" bowl and 8" high back and side splashes. Additionally, this hand sink has two holes punched on 4" centers to accept its included Regency 8" gooseneck faucet.

This sink offers an economical, 20-gauge type 304 stainless steel construction along its top, bowl, and backspash, in addition to 18-gauge type 304 stainless steel side splashes and a wall mounted clip. It comes standard with a 1 1/2" IPS drain basket.

**⚠ WARNING:** This product can expose you to chemicals including Lead and Nickel, which are known to the State of California to cause cancer, birth defects, or other reproductive harm. For more information, go to [www.p65warnings.ca.gov](http://www.p65warnings.ca.gov).

Deliver to Michelle  
Orangeburg 10962

All ▼ concession++window++for++food+truck

Hello, Michelle Returns  
Account & Lists ▼ & Orders

0

- All Medical Care ▼ Buy Again Customer Service Amazon Basics Today's Deals Household Health & Baby Care Groceries ▼ Coupons Livestreams Handmade Subscribe & Save Amazon Business ▼
- Industrial & Scientific Janitorial & Facilities Safety Supplies Medical Supplies Food Service Diagnostic Equipment Material Handling Educational Supplies Sealants and Lubricants Additive Manufacturing Laboratory Supplies
- Tools & Home Improvement › Hardware › Window Hardware › Screens

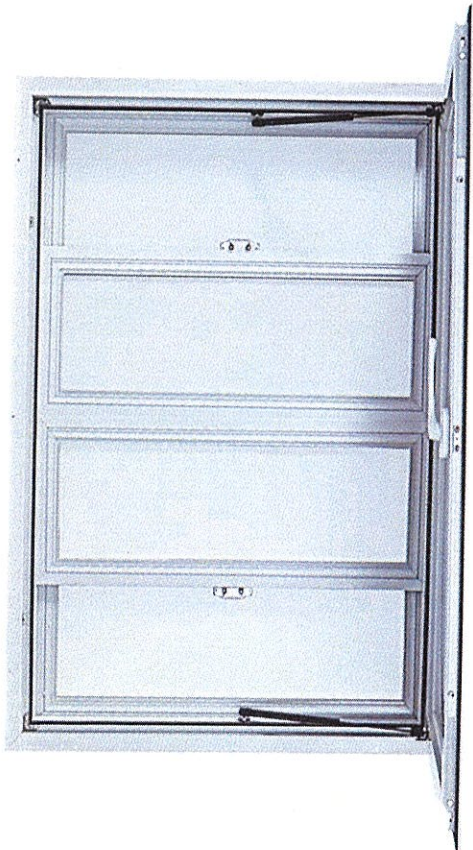

Concession Window 60 x 36 inch, Aluminum Alloy Food Truck Service Window with 4 Horizontal Sliding Screen Windows & Awning Door & Drag Hook, Serving Window for Food Trucks Concession Trailers

Visit the VEVOR Store  
3.9  
50+ bought in past month

\$569.99

Or \$33.65 /mo (24 mo). Select from 1 plan

Pay \$47.50/month for 12 months, interest-free upon approval for Prime Visa

Delivery & Support

Select to learn more

- Ships from Cenx Eligible for Return, Refund or Replacement within 30 day... Customer Support

Roll over image to zoom in

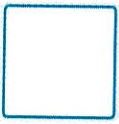

Available with free Prime shipping from other sellers on Amazon.  
Size Name: 60 x 36 Inch

36 x 36 Inch	48 x 36 Inch	53 x 33 Inch	<b>60 x 36 Inch</b>
\$340.85	\$489.99	\$481.99	<b>\$569.99</b>

<b>Material</b>	304 Stainless Steel, Stainless Steel, Aluminum, Steel
<b>Orientation</b>	Drivers Side
<b>Color</b>	Silver
<b>Brand</b>	VEVOR
<b>Item Thickness</b>	5.5 Inches

About this item

- Premium Material: Our concession window adopts an aluminum alloy frame with 0.05 inch / 1.2 mm thickness, ensuring durability, sturdiness, and

Buy new: \$569.99

FREE delivery March 12 - 14.

Details

Deliver to Michelle - Orangeburg 10962

In Stock

Quantity: 1

Add to Cart

Buy Now

Ships from Sold by Cenx Returns Eligible for Return, Refund or Replacement... Secure transaction

Payment  
See more

Save with Used - Like New \$546.51

FREE delivery: Tuesday, March 12  
Ships from: Amazon  
Sold by: Amazon Warehouse

Add to List

New & Used (2) from \$546.51

**GENERAL**

ACCOUNT NO	ACCOUNT DESCRIPTION	ORIGINAL/ ADJUSTED BUDGET	04/02/24	2023 Final Adjusted Budget
			RTBM 2023 Final Budget Adjustment	
A.1010.100	TOWN BOARD.ELECTED OFFICIALS	123,600	769	124,369
A.1110.440.01	TOWN JUSTICE.OFFICE SUPPLIES & PRINT	-	547	547
A.1110.440.13	TOWN JUSTICE.OFFICE SUPPLIES & PRINT.COMPUTER SUPPLIES	-	378	378
A.1110.100	TOWN JUSTICE.ELECTED OFFICIALS	144,200	5,000	149,200
A.1110.442	TOWN JUSTICE.POSTAGE	6,500	923	7,423
A.1110.011	TOWN JUSTICE.PERMANENT STAFF	226,339	77	226,416
A.1110.457	TOWN JUSTICE.CONTRACTS W/OUTSIDE VENDORS	4,000	(2,895)	1,105
A.1110.012	TOWN JUSTICE.TIME & ONE HALF	4,800	(4,800)	-
A.1220.440.13	SUPERVISOR.OFFICE SUPPLIES & PRINT.COMPUTER SUPPLIES	-	431	431
A.1220.200	SUPERVISOR.CAPITAL OUTLAY	-	57,070	57,070
A.1220.457	SUPERVISOR.CONTRACTS W/OUTSIDE VENDORS	-	3,122	3,122
A.1220.480	SUPERVISOR.TRAVEL EXPENSES	-	2,440	2,440
A.1220.471	SUPERVISOR.TELEPHONE	500	2,396	2,896
A.1220.011	SUPERVISOR.PERMANENT STAFF	106,193	2,334	108,527
A.1220.441	SUPERVISOR.SCHOOLS & CONFERENCES	-	942	942
A.1220.013	SUPERVISOR.SEASONAL & PART TIME	5,000	(4,912)	88
A.1220.015	SUPERVISOR.APPOINTED OFFICIALS	182,222	(5,000)	177,222
A.1220.443	SUPERVISOR.MAINTENANCE AGREEMENTS	10,000	(8,822)	1,178
A.3089	STATE AID OTHER	(316,100)	(50,000)	(366,100)
A.1310.440.01	FINANCE.OFFICE SUPPLIES & PRINT	-	4,559	4,559
A.1310.457.01	FINANCE.CONTRACTS W/OUTSIDE VENDORS.CONTRACT WITH OUTSIDE VENDORS	1,400	(523)	877
A.1310.011	FINANCE.PERMANENT STAFF	379,794	29,955	409,749
A.1310.013	FINANCE.SEASONAL & PART TIME	10,000	1,213	11,213
A.1310.442	FINANCE.POSTAGE	500	157	657
A.1310.441	FINANCE.SCHOOLS & CONFERENCES	3,250	(55)	3,195
A.1310.480	FINANCE.TRAVEL EXPENSES	3,000	(1,302)	1,698
A.1310.443	FINANCE.MAINTENANCE AGREEMENTS	48,500	(6,177)	42,323
A.1310.012	FINANCE.TIME & ONE HALF	10,000	(10,000)	-
A.1320.457	INDEPENDENT AUDIT.CONTRACTS W/OUTSIDE VENDORS	79,976	22,924	102,900
A.1330.440.01	RECEIVER OF TAXES.OFFICE SUPPLIES & PRINT	-	8,233	8,233
A.1330.442	RECEIVER OF TAXES.POSTAGE	15,500	2,017	17,517

**GENERAL**

ACCOUNT NO	ACCOUNT DESCRIPTION	ORIGINAL/ ADJUSTED BUDGET	04/02/24	2023 Final Adjusted Budget
			RTBM 2023 Final Budget Adjustment	
A.1330.457	RECEIVER OF TAXES.CONTRACTS W/OUTSIDE VENDORS	12,100	(10,250)	1,850
A.1355.440.13	ASSESSOR.OFFICE SUPPLIES & PRINT.COMPUTER SUPPLIES	-	774	774
A.1355.013	ASSESSOR.SEASONAL & PART TIME	-	36,650	36,650
A.1355.485	ASSESSOR.CERTIORARI EXPENSE	15,000	32,500	47,500
A.1355.441	ASSESSOR.SCHOOLS & CONFERENCES	-	2,271	2,271
A.1355.443	ASSESSOR.MAINTENANCE AGREEMENTS	400	1,844	2,244
A.1355.471	ASSESSOR.TELEPHONE	-	480	480
A.1355.445	ASSESSOR.BOOKS AND PUBLICATIONS	3,500	145	3,645
A.1355.407	ASSESSOR.ADVERTISING	100	100	200
A.1355.011	ASSESSOR.PERMANENT STAFF	376,569	(80,913)	295,656
A.1356.457	BD OF ASSESSMENT REVIEW.CONTRACTS W/OUTSIDE VENDORS	10,000	6,150	16,150
A.1410.440.01	TOWN CLERK.OFFICE SUPPLIES & PRINT	-	734	734
A.1410.455	TOWN CLERK.UTILITIES	16,800	15,728	32,528
A.1410.013	TOWN CLERK.SEASONAL & PART TIME	15,000	3,423	18,423
A.1410.407	TOWN CLERK.ADVERTISING	7,000	3,199	10,199
A.1410.011	TOWN CLERK.PERMANENT STAFF	228,781	1,592	230,373
A.1410.457	TOWN CLERK.CONTRACTS W/OUTSIDE VENDORS	9,100	(7,582)	1,518
A.1410.443	TOWN CLERK.MAINTENANCE AGREEMENTS	4,931	661	5,592
A.1410.471	TOWN CLERK.TELEPHONE	-	364	364
A.1410.444	TOWN CLERK.RENTAL OF EQUIPMENT	1,234	(64)	1,170
A.1410.473	TOWN CLERK.WATER	1,430	(68)	1,362
A.1410.442	TOWN CLERK.POSTAGE	1,600	(348)	1,252
A.1410.441	TOWN CLERK.SCHOOLS & CONFERENCES	600	(495)	105
A.1410.480	TOWN CLERK.TRAVEL EXPENSES	2,000	(2,000)	-
A.1410.445	TOWN CLERK.BOOKS AND PUBLICATIONS	6,000	(3,405)	2,595
A.1420.440.01	TOWN ATTORNEY.OFFICE SUPPLIES & PRINT	-	516	516
A.1420.015	TOWN ATTORNEY.APPOINTED OFFICIALS	455,146	24,048	479,194
A.1420.011	TOWN ATTORNEY.PERMANENT STAFF	92,043	3,110	95,153
A.1420.441	TOWN ATTORNEY.SCHOOLS & CONFERENCES	2,000	430	2,430
A.1420.471	TOWN ATTORNEY.TELEPHONE	-	361	361
A.1420.456	TOWN ATTORNEY.COPIES OF TESTIMONY	-	200	200

**GENERAL**

ACCOUNT NO	ACCOUNT DESCRIPTION	ORIGINAL/ ADJUSTED BUDGET	04/02/24	2023 Final Adjusted Budget
			RTBM 2023 Final Budget Adjustment	
A.1420.480	TOWN ATTORNEY.TRAVEL EXPENSES	500	156	656
A.1420.013	TOWN ATTORNEY.SEASONAL & PART TIME	60,000	(28,821)	31,179
A.1440.011	ENGINEER.PERMANENT STAFF	516,173	9,757	525,930
A.1440.012	ENGINEER.TIME & ONE HALF	20,536	9,482	30,018
A.1440.471	ENGINEER.TELEPHONE	935	1,926	2,861
A.1440.443	ENGINEER.MAINTENANCE AGREEMENTS	-	1,414	1,414
A.1440.457	ENGINEER.CONTRACTS W/OUTSIDE VENDORS	-	191	191
A.1440.013	ENGINEER.SEASONAL & PART TIME	40,000	(22,770)	17,230
A.1450.457	ELECTIONS.CONTRACTS W/OUTSIDE VENDORS	185,000	97,126	282,126
A.1620.446	BUILDING MAINTENANCE.MTCE AND HOUSEKEEPING SUPPLIES	18,500	4,266	22,766
A.1620.455	BUILDING MAINTENANCE.UTILITIES	10,000	1,580	11,580
A.1620.471	BUILDING MAINTENANCE.TELEPHONE	-	40	40
A.1620.473	BUILDING MAINTENANCE.WATER	72,000	(5,886)	66,114
A.1622.455	SHARED SERVICES.UTILITIES	45,000	24,092	69,092
A.1622.013	SHARED SERVICES.SEASONAL & PART TIME	10,000	9,949	19,949
A.1622.473	SHARED SERVICES.WATER	3,500	3,031	6,531
A.1622.011	SHARED SERVICES.PERMANENT STAFF	49,453	504	49,957
A.1622.443	SHARED SERVICES.MAINTENANCE AGREEMENTS	5,000	(199)	4,801
A.1622.444	SHARED SERVICES.RENTAL OF EQUIPMENT	4,500	(744)	3,756
A.1622.471	SHARED SERVICES.TELEPHONE	20,000	(1,492)	18,508
A.1622.442	SHARED SERVICES.POSTAGE	7,000	(2,971)	4,029
A.1622.457	SHARED SERVICES.CONTRACTS W/OUTSIDE VENDORS	217,065	(29,373)	187,692
A.1682.440.01	CENTRAL DATA.OFFICE SUPPLIES & PRINT	-	1,631	1,631
A.1682.440.13	CENTRAL DATA.OFFICE SUPPLIES & PRINT.COMPUTER SUPPLIES	28,250	698	28,948
A.1682.013	CENTRAL DATA.SEASONAL & PART TIME	15,000	39,551	54,551
A.1682.011	CENTRAL DATA.PERMANENT STAFF	181,122	19,666	200,788
A.1682.471	CENTRAL DATA.TELEPHONE	-	2,038	2,038
A.1682.012	CENTRAL DATA.TIME & ONE HALF	9,500	1,929	11,429
A.1682.457	CENTRAL DATA.CONTRACTS W/OUTSIDE VENDORS	653,644	(65,513)	588,131
A.1930.487	JUDGMENTS & CLAIMS.REFUNDS OF REAL PROPERTY	72,527	60,855	133,382
A.3310.455	TRAFFIC CONTROL.UTILITIES	34,000	5,661	39,661



**GENERAL**

ACCOUNT NO	ACCOUNT DESCRIPTION	ORIGINAL/ ADJUSTED BUDGET	04/02/24	2023 Final Adjusted Budget
			RTBM 2023 Final Budget Adjustment	
A.3310.200	TRAFFIC CONTROL.CAPITAL OUTLAY	10,000	(5,661)	4,339
A.5010.015	SUPT. OF HIGHWAYS.APPOINTED OFFICIALS	1,300	974	2,274
A.5010.471	SUPT. OF HIGHWAYS.TELEPHONE	2,800	747	3,547
A.5010.442	SUPT. OF HIGHWAYS.POSTAGE	1,000	455	1,455
A.5010.480	SUPT. OF HIGHWAYS.TRAVEL EXPENSES	500	200	700
A.5010.457	SUPT. OF HIGHWAYS.CONTRACTS W/OUTSIDE VENDORS	20,000	(1,402)	18,598
A.5010.011	SUPT. OF HIGHWAYS.PERMANENT STAFF	273,066	(974)	272,092
A.5132.455	GARAGE.UTILITIES	53,000	4,089	57,089
A.5132.440	GARAGE.OFFICE SUPPLIES & PRINT	600	87	687
A.5132.453	GARAGE.PAINTING AND BUILDING REPAIRS	10,000	(32)	9,968
A.5132.457	GARAGE.CONTRACTS W/OUTSIDE VENDORS	20,000	(4,144)	15,856
A.6772.457	PROGRAMS FOR THE AGING.CONTRACTS W/OUTSIDE VENDORS	185,000	19,766	204,766
A.6772.015	PROGRAMS FOR THE AGING.APPOINTED OFFICIALS	6,500	(6,000)	500
A.7020.440.13	PARKS & REC ADMIN.OFFICE SUPPLIES & PRINT.COMPUTER SUPPLIES	-	42	42
A.7020.020	PARKS & REC ADMIN.DOUBLE TIME	-	619	619
A.7020.471	PARKS & REC ADMIN.TELEPHONE	1,400	481	1,881
A.7020.200	PARKS & REC ADMIN.CAPITAL OUTLAY	-	314	314
A.7020.443	PARKS & REC ADMIN.MAINTENANCE AGREEMENTS	500	55	555
A.7020.012	PARKS & REC ADMIN.TIME & ONE HALF	5,000	(271)	4,729
A.7020.444	PARKS & REC ADMIN.RENTAL OF EQUIPMENT	3,000	(1,242)	1,758
A.7110.440.01	PARKS.OFFICE SUPPLIES & PRINT	-	21	21
A.7110.200	PARKS.CAPITAL OUTLAY	336,100	28,636	364,736
A.7110.473	PARKS.WATER	2,500	24,819	27,319
A.7110.457	PARKS.CONTRACTS W/OUTSIDE VENDORS	80,000	5,450	85,450
A.7110.447	PARKS.VEHICLE OPERATION AND REPAIR	40,000	3,761	43,761
A.7110.471	PARKS.TELEPHONE	500	2,566	3,066
A.7110.011	PARKS.PERMANENT STAFF	750,401	2,342	752,743
A.7110.441	PARKS.SCHOOLS & CONFERENCES	200	260	460
A.7110.480	PARKS.TRAVEL EXPENSES	-	28	28
A.7110.446	PARKS.MTCE AND HOUSEKEEPING SUPPLIES	5,000	(66)	4,934
A.7110.465	PARKS.UNIFORMS	7,000	(306)	6,694

**GENERAL**

ACCOUNT NO	ACCOUNT DESCRIPTION	ORIGINAL/ ADJUSTED BUDGET	04/02/24	2023 Final Adjusted Budget
			RTBM 2023 Final Budget Adjustment	
A.7110.455	PARKS.UTILITIES	73,000	(1,634)	71,366
A.7110.453	PARKS.PAINTING AND BUILDING REPAIRS	10,000	(1,855)	8,145
A.7110.460	PARKS.LANDSCAPING	42,000	(2,021)	39,979
A.7110.449	PARKS.CHEMICALS	10,000	(4,104)	5,896
A.7110.020	PARKS.DOUBLE TIME	15,000	(4,522)	10,478
A.7110.462	PARKS.GASOLINE AND DIESEL FUEL	10,000	(6,665)	3,335
A.7110.012	PARKS.TIME & ONE HALF	25,000	(7,986)	17,014
A.7110.013	PARKS.SEASONAL & PART TIME	60,000	(19,476)	40,524
A.7110.300	PARKS.CAPITAL FACILITIES	75,782	(19,249)	56,532
A.7180.455	SPECIAL RECREATIONAL FACILITIES.UTILITIES	65,000	38,967	103,967
A.7180.457	SPECIAL RECREATIONAL FACILITIES.CONTRACTS W/OUTSIDE VENDORS	5,000	1,625	6,625
A.7180.473	SPECIAL RECREATIONAL FACILITIES.WATER	18,000	191	18,191
A.7310.471	YOUTH RECREATION.TELEPHONE	3,000	1,274	4,274
A.7310.013	YOUTH RECREATION.SEASONAL & PART TIME	360,000	(7,438)	352,562
A.7310.457	YOUTH RECREATION.CONTRACTS W/OUTSIDE VENDORS	425,000	(42,056)	382,944
A.7520.471	TOWN MUSEUM.TELEPHONE	1,400	1,406	2,806
A.7520.455	TOWN MUSEUM.UTILITIES	9,000	980	9,980
A.7520.443	TOWN MUSEUM.MAINTENANCE AGREEMENTS	2,500	684	3,184
A.7520.446	TOWN MUSEUM.MTCE AND HOUSEKEEPING SUPPLIES	1,100	314	1,414
A.7520.013	TOWN MUSEUM.SEASONAL & PART TIME	16,000	(3,384)	12,616
A.7550.012	CELEBRATIONS.TIME & ONE HALF	4,500	7,969	12,469
A.7550.457	CELEBRATIONS.CONTRACTS W/OUTSIDE VENDORS	15,000	3,543	18,543
A.7550.011	CELEBRATIONS.PERMANENT STAFF	-	297	297
A.7550.020	CELEBRATIONS.DOUBLE TIME	75,000	(11,810)	63,190
A.7620.457	ADULT RECREATION.CONTRACTS W/OUTSIDE VENDORS	45,000	6,498	51,498
A.7620.013	ADULT RECREATION.SEASONAL & PART TIME	20,000	939	20,939
A.8160.457	REFUSE AND GARBAGE.CONTRACTS W/OUTSIDE VENDORS	85,000	(1,067)	83,933
A.8189.457	SANITATION COMMISSION.CONTRACTS W/OUTSIDE VENDORS	-	1,067	1,067
A.9010.800	RETIREMENT.FRINGE BENEFITS	881,100	(174,711)	706,389
A.9030.800	SS / MEDICARE.FRINGE BENEFITS	514,407	(40,006)	474,401
A.9061.800	DENTAL INSURANCE.FRINGE BENEFITS	161,633	(12,317)	149,316

**GENERAL**

<b>ACCOUNT NO</b>	<b>ACCOUNT DESCRIPTION</b>	<b>ORIGINAL/ ADJUSTED BUDGET</b>	<b>04/02/24</b>	<b>2023 Final</b>
			<b>RTBM 2023 Final Budget Adjustment</b>	<b>Adjusted Budget</b>
A.9950.900	INTERFUND TRANSFERS.TRANSFERS	-	827,143	827,143
A.3599	APPROPRIATED FUND BALANCE	(833,500)	(827,143)	(1,660,643)

**TOV POLICE**

ACCOUNT NO	ACCOUNT DESCRIPTION	ORIGINAL/ ADJUSTED BUDGET	04/02/24	
			RTBM 2023 Final Budget Adjustment	2023 Final Adjusted Budget
B.3120.011.16	POLICE.PERMANENT STAFF.POLICE	12,701,407	307,389	13,008,796
B.3120.012.11	POLICE.TIME & ONE HALF.DARE	-	12,986	12,986
B.3120.012.16	POLICE.TIME & ONE HALF.POLICE	1,810,000	(152,591)	1,657,409
B.3120.016.16	POLICE.HOLIDAY PAY.POLICE	395,000	103,194	498,194
B.3120.021.16	POLICE.SICK LEAVE.POLICE	325,000	(209,272)	115,728
B.3120.022.16	POLICE.VACATION BUYOUT.POLICE	175,000	(57,478)	117,522
B.3120.200.16	POLICE.CAPITAL OUTLAY.POLICE	-	268,254	268,254
B.2625.000.16	RICO.POLICE	-	(187,046)	(187,046)
B.3120.408.16	POLICE.RICO ENHANCEMENTS.POLICE	87,882	28,258	116,140
B.3120.447.16	POLICE.VEHICLE OPERATION AND REPAIR.POLICE	80,000	895	80,895
B.3120.455.16	POLICE.UTILITIES.POLICE	75,000	29,124	104,124
B.3120.471.16	POLICE.TELEPHONE.POLICE	45,000	23,559	68,559
B.3122.011.16	RADIO OPERATORS.PERMANENT STAFF.POLICE	363,123	23,815	386,938
B.3122.020.16	RADIO OPERATORS.DOUBLE TIME.POLICE	17,500	1,931	19,431
B.3124.011.16	SUPPORT STAFF.PERMANENT STAFF.POLICE	333,630	61,502	395,132
B.3124.012.16	SUPPORT STAFF.TIME & ONE HALF.POLICE	12,000	8,905	20,905
B.3124.013.16	SUPPORT STAFF.SEASONAL & PART TIME.POLICE	5,000	1,639	6,639
B.9015.800.16	POLICE RETIREMENT.FRINGE BENEFITS.POLICE	4,440,345	29,203	4,469,548
B.9030.800.16	SS / MEDICARE.FRINGE BENEFITS.POLICE	1,069,868	3,465	1,073,333
B.9045.800.16	POLICE LIFE INSURANCE.FRINGE BENEFITS.POLICE	52,500	(9,546)	42,954
B.9050.800.16	UNEMPLOYMENT INSURANCE.FRINGE BENEFITS.POLICE	5,000	(5,000)	-
B.9060.800.16	HOSPITALIZATION.FRINGE BENEFITS.POLICE	5,132,889	320,243	5,453,132
B.9061.800.16	DENTAL INSURANCE.FRINGE BENEFITS.POLICE	282,235	(101,797)	180,438
B.2401.000.16	INTEREST EARNINGS.POLICE	(200,000)	(501,631)	(701,631)

**TOV OTHER**

B.1980.457.17	MCT MOBILITY TAX.CONTRACTS W/OUTSIDE VENDORS.OTHER THAN POLICE	5,673	662	6,335
B.3620.015.17	SAFETY INSPECTION SERVICE.APPOINTED OFFICIALS.OTHER THAN POLICE	193,993	56,868	250,861
B.3620.200.17	SAFETY INSPECTION SERVICE.CAPITAL OUTLAY.OTHER THAN POLICE	82,627	625	83,252
B.3620.440.13	SAFETY INSPECTION SERVICE.OFFICE SUPPLIES & PRINT.COMPUTER SUPPLIES	2,000	1,300	3,300

**TOV POLICE**

<b>ACCOUNT NO</b>	<b>ACCOUNT DESCRIPTION</b>	<b>ORIGINAL/ ADJUSTED BUDGET</b>	<b>04/02/24</b>	<b>2023 Final</b>
			<b>RTBM 2023 Final Budget Adjustment</b>	<b>Adjusted Budget</b>
B.3620.443.17	SAFETY INSPECTION SERVICE.MAINTENANCE AGREEMENTS.OTHER THAN POLICE	54,000	6,614	60,614
B.3620.450.17	SAFETY INSPECTION SERVICE.PHOTO AND MICROFILM SUPPLIES.OTHER THAN POLICE	-	4,511	4,511
B.3620.455.17	SAFETY INSPECTION SERVICE.UTILITIES.OTHER THAN POLICE	6,000	1,777	7,777
B.3620.471.17	SAFETY INSPECTION SERVICE.TELEPHONE.OTHER THAN POLICE	8,000	350	8,350
B.3621.011.17	FIRE SAFETY.PERMANENT STAFF.OTHER THAN POLICE	274,090	23,293	297,383
B.3621.012.17	FIRE SAFETY.TIME & ONE HALF.OTHER THAN POLICE	4,000	3,294	7,294
B.3621.013.17	FIRE SAFETY.SEASONAL & PART TIME.OTHER THAN POLICE	52,000	3,608	55,608
B.3621.020.17	FIRE SAFETY.DOUBLE TIME.OTHER THAN POLICE	3,250	1,840	5,090
B.3621.455.17	FIRE SAFETY.UTILITIES.OTHER THAN POLICE	2,500	1,303	3,803
B.5182.452.17	STREET LIGHTING.EQUIPMENT REPAIRS.OTHER THAN POLICE	-	1,680	1,680
B.8010.011.17	ZONING BOARD OF APPEALS.PERMANENT STAFF.OTHER THAN POLICE	120,134	15,789	135,923
B.8010.440.01	ZONING BOARD OF APPEALS.OFFICE SUPPLIES & PRINT	2,250	258	2,508
B.8010.455.17	ZONING BOARD OF APPEALS.UTILITIES.OTHER THAN POLICE	6,750	1,027	7,777
B.8011.015.17	HABOR.APPOINTED OFFICIALS.OTHER THAN POLICE	12,129	1	12,130
B.8020.013.17	PLANNING BOARD.SEASONAL & PART TIME.OTHER THAN POLICE	-	57,992	57,992
B.8020.455.17	PLANNING BOARD.UTILITIES.OTHER THAN POLICE	5,200	2,577	7,777
B.8160.200.17	REFUSE AND GARBAGE.CAPITAL OUTLAY.OTHER THAN POLICE	-	5,377	5,377
B.9060.800.17	HOSPITALIZATION.FRINGE BENEFITS.OTHER THAN POLICE	526,942	(133,572)	393,370
B.9061.800.17	DENTAL INSURANCE.FRINGE BENEFITS.OTHER THAN POLICE	30,247	5,176	35,423
B.2401.000.17	INTEREST EARNINGS.OTHER THAN POLICE	(30,000)	(62,350)	(92,350)

**HIGHWAY-PART TOWN**

ACCOUNT NO	ACCOUNT DESCRIPTION	ORIGINAL/ ADJUSTED BUDGET	04/02/24	2023 Final Adjusted Budget
			RTBM 2023 Final Budget Adjustment	
D.1989.478.04	UNCLASSIFIED.INTERFUND CHARGES FOR SERVICES.PART TOWN	783,514	1	783,515
D.5110.200.04	HIGHWAY REPAIR & IMPROVE.CAPITAL OUTLAY.PART TOWN	-	383,149	383,149
D.5110.012.04	HIGHWAY REPAIR & IMPROVE.TIME & ONE HALF.PART TOWN	53,000	7,521	60,521
D.5110.013.04	HIGHWAY REPAIR & IMPROVE.SEASONAL & PART TIME.PART TOWN	53,000	1,823	54,823
D.5110.011.04	HIGHWAY REPAIR & IMPROVE.PERMANENT STAFF.PART TOWN	2,664,911	(101,284)	2,563,627
D.5112.200.04	PERMANENT IMPROV (CHIPS).CAPITAL OUTLAY.PART TOWN	-	96,463	96,463
D.9010.800.04	RETIREMENT.FRINGE BENEFITS.PART TOWN	424,349	(92,331)	332,018
D.9030.800.04	SS / MEDICARE.FRINGE BENEFITS.PART TOWN	170,240	29,461	199,701
D.9060.800.04	HOSPITALIZATION.FRINGE BENEFITS.PART TOWN	835,794	(9,646)	826,148
D.9061.800.04	DENTAL INSURANCE.FRINGE BENEFITS.PART TOWN	47,217	7,001	54,218
D.2401.000.04	INTEREST EARNINGS.PART TOWN	(50,000)	(50,000)	(100,000)
D.4089.000.04	FEDERAL GRANTS.PART TOWN	-	(272,159)	(272,159)

**HIGHWAY TOWNWIDE**

D.5110.457.05	HIGHWAY REPAIR & IMPROVE.CONTRACTS W/OUTSIDE VENDORS.TOWNWIDE	-	617	617
D.5140.020.05	MISC. BRUSH & WEEDS.DOUBLE TIME.TOWNWIDE	100,000	33,886	133,886
D.5140.011.05	MISC. BRUSH & WEEDS.PERMANENT STAFF.TOWNWIDE	1,359,508	28,595	1,388,103
D.5142.020.05	SNOW REMOVAL.DOUBLE TIME.TOWNWIDE	200,000	(95,157)	104,843
D.9050.800.05	UNEMPLOYMENT INSURANCE.FRINGE BENEFITS.TOWNWIDE	7,000	3,113	10,113
D.9061.800.05	DENTAL INSURANCE.FRINGE BENEFITS.TOWNWIDE	34,977	28,946	63,923
		1,701,485	-	1,701,485

**DEME**

ACCOUNT NO	ACCOUNT DESCRIPTION	04/02/24		
		ORIGINAL/ ADJUSTED BUDGET	RTBM 2023 Final Budget Adjustment	2023 Final Adjusted Budget
G.8110.440.01	SEWER ADMINISTRATION.OFFICE SUPPLIES & PRINT	5,375	751	6,126
G.8110.015	SEWER ADMINISTRATION.APPOINTED OFFICIALS	483,098	26,824	509,922
G.8110.471	SEWER ADMINISTRATION.TELEPHONE	15,030	2,802	17,832
G.8110.443	SEWER ADMINISTRATION.MAINTENANCE AGREEMENTS	500	55	555
G.8110.480	SEWER ADMINISTRATION.TRAVEL EXPENSES	1,500	(806)	694
G.8110.011	SEWER ADMINISTRATION.PERMANENT STAFF	355,525	(49,730)	305,795
G.8120.200.09	SEWER COLLECTION SYSTEM.CAPITAL OUTLAY.EMERGENCY WORK	69,985	4,207	74,192
G.8120.200	SEWER COLLECTION SYSTEM.CAPITAL OUTLAY	163,000	(4,207)	158,793
G.8120.012	SEWER COLLECTION SYSTEM.TIME & ONE HALF	54,000	15,291	69,291
G.8120.471	SEWER COLLECTION SYSTEM.TELEPHONE	-	4,812	4,812
G.8120.439	SEWER COLLECTION SYSTEM.OPERATION SUPPLIES	30,000	(27,098)	2,902
G.8121.463	INDUSTRIAL PRETREATMENT.LABORATORY TESTING	50,000	24,315	74,315
G.8121.011	INDUSTRIAL PRETREATMENT.PERMANENT STAFF	122,624	2,358	124,982
G.8121.457	INDUSTRIAL PRETREATMENT.CONTRACTS W/OUTSIDE VENDORS	7,000	425	7,425
G.8130.473	SEWAGE TREATMENT PLANT.WATER	100,000	8,529	108,529
G.8130.452	SEWAGE TREATMENT PLANT.EQUIPMENT REPAIRS	87,000	8,194	95,194
G.8130.447	SEWAGE TREATMENT PLANT.VEHICLE OPERATION AND REPAIR	12,182	8,056	20,238
G.8130.012	SEWAGE TREATMENT PLANT.TIME & ONE HALF	91,000	4,542	95,542
G.8130.011	SEWAGE TREATMENT PLANT.PERMANENT STAFF	1,618,479	2,550	1,621,029
G.8130.465	SEWAGE TREATMENT PLANT.UNIFORMS	29,000	385	29,385
G.8130.403	SEWAGE TREATMENT PLANT.STATE ENVIRONMENTAL FEE	20,000	300	20,300
G.8130.020	SEWAGE TREATMENT PLANT.DOUBLE TIME	141,000	(32,556)	108,444
G.9010.800	RETIREMENT.FRINGE BENEFITS	684,460	(85,640)	598,820
G.9030.800	SS / MEDICARE.FRINGE BENEFITS	260,138	35,017	295,155
G.9060.800	HOSPITALIZATION.FRINGE BENEFITS	1,350,591	23,864	1,374,455
G.9061.800	DENTAL INSURANCE.FRINGE BENEFITS	54,905	26,759	81,664

**DEBT**

<b>ACCOUNT NO</b>	<b>ACCOUNT DESCRIPTION</b>	<b>ORIGINAL/ ADJUSTED BUDGET</b>	<b>04/02/24</b>	<b>2023 Final Adjusted Budget</b>
			<b>RTBM 2023 Final Budget Adjustment</b>	
V.1380.457	FISCAL AGENT FEES.CONTRACTS W/OUTSIDE VENDORS	15,000	(1)	14,999
V.9789.700.42	ENERGY PERFORMANCE.BOND INTEREST.FACILITY REPAIRS 2004	11,332	1	11,333
V.9789.600.42	ENERGY PERFORMANCE.BOND PRINCIPAL.FACILITY REPAIRS 2004	203,981	(1)	203,980
V.9710.700.20	SERIAL BOND DEBT SERVICE.BOND INTEREST.2020 BONDING	293,923	836	294,759
V.9710.600.20	SERIAL BOND DEBT SERVICE.BOND PRINCIPAL.2020 BONDING	393,696	(836)	392,860
V.9710.700.51	SERIAL BOND DEBT SERVICE.BOND INTEREST.PARK LANDS AND GENERAL FUND	115,479	1	115,480
V.9789.700.18	ENERGY PERFORMANCE.BOND INTEREST.LED CONVERSION	36,481	28,345	64,826
V.2401.000.00	INTEREST EARNINGS	(200,000)	(28,345)	(228,345)





## Portable Toilet Request Form

The Town of Orangetown accepts requests for portable toilets from not-for-profit groups for their events and programs. Applications must be submitted 8 weeks prior to the event. In case of any changes, the organization must contact Mark Albert at [malbert@orangetown.com](mailto:malbert@orangetown.com) no later than 48 hours prior to the event.

### Event Information

---

**Event Name \*** Lt John G Bellew 5K Fun Run/Walk

**Event Location Name \*** Pearl River Firehouse/Central Ave Field

**Event Address \***

Street Address  
58 Central Avenue  
Address Line 2  
185 Ridge Street  
City Pearl River State / Province / Region NY  
Postal / Zip Code 10965 Country USA

**Event Start Date \*** 4/27/2024  
09:00:00 AM

**Event End Date \*** 4/27/2024  
03:00:00 PM

**Set-up Info \*** Please describe the exact location the units should be placed on the event site  
Back of parking Lot of Pearl River Firehouse on Central Avenue against the fence separating parking lot from Central Ave Field

**Number of regular units required \*** 1

**Number of ADA units required \*** 1

**Total Number of units required \*** 2

### Applicant Information

---

**Applicant First Name \*** John

**Applicant Last Name \*** Sullivan

**Organization Name \*** Lt John G Bellew 5K Fun Run/Walk

**Organization Not For Profit? \***  Yes  
 No

**Organization Address \***

Street Address

185 Ridge Street

Address Line 2

185 Ridge Street

City

Pearl River

State / Province / Region

NY

Postal / Zip Code

10965

Country

USA

**Phone (w) \***

845 735-2764

**Phone (c) \***

718 644-4230

**Email \***

ejsully1@verizon.net

**Certificate of Insurance \***

GAP120624 Town of Oranget 2023-12-12.pdf

96.97KB

Certificate must list the Town of Orangetown as additional Insured

**Signature \***



*John M Sullivan*

---

---

**TOWN OF ORANGETOWN  
FINANCE OFFICE MEMORANDUM**

---

---

**TO:** THE TOWN BOARD  
**FROM:** JEFF BENCIK, *DIRECTOR OF FINANCE*  
**SUBJECT:** AUDIT MEMO  
**DATE:** 03/28/24  
**CC:** DEPARTMENT HEADS



---

The audit for the Town Board Meeting of 04/02/2024 consists of 3 warrants for a total of \$1,047,250.06.

The first warrant had 21 vouchers for \$66,919.76 and was for utilities and had the following item of interest.

1. (p4&5) - 207c benefit payments.

The second warrant had 29 vouchers for \$47,681.12 and was for utilities.

The third warrant had 165 vouchers for \$932,649.18 and had the following items of interest.

1. BDP Industries, Inc (p8) - \$9,405.60 and was for DEME equipment repair.
2. CSEA Employee Benefit Fund (p15) - \$33,663.52 for dental benefits.
3. De Lage Landen Public Finance LLC (p15) - \$24,868.80 for monthly golf cart lease.
4. Fanshawe, Inc (p18) - \$60,207.58 electrical contractor for new Town Hall.
5. Filebank, Inc (p19) - \$8,698.84 for scanning Clerk documents.
6. Foley Signs Inc (p21) - \$5,810 for a new Salyer House sign.
7. Global Montello Group Corp (p23) - \$39,169.62 for fuel.
8. Keane & Beane, PC (p29&30) - \$12,504.32 for outside counsel.
9. Paessler AG (p36) - \$5,313.75 for computer software.
10. Piermont Senior Citizens Club (p37) – \$5,000 for trips.
11. PKF O'Connor Davies, LLP (p38) - \$78,750 for 2023 audit progress billing.
12. Troon Golf LLC (p48&49) - \$14,500.62 management fee (CPI index).

13. Vanas Construction Co. Inc (p51) - \$83,526.85 GC for new Town Hall.

14. Zarin & Steinmetz (p54&55) - \$32,200 for outside counsel.

Please feel free to contact me with any questions or comments.

Jeffrey W. Bencik, CFA  
845-359-5100 x2204

**WARRANT**

---

**Warrant Reference**

**Warrant #**

**Amount**

Approved for payment in the amount of

031524	\$	66,919.76	utilities & 207c benefits
032224	\$	47,681.12	utilities
040224	\$	932,649.18	

\$ 1,047,250.06

The above listed claims are approved and ordered paid from the appropriations indicated.

**APPROVAL FOR PAYMENT**

---

**AUDITING BOARD**

---

---

**Councilman Gerald Bottari**

---

**Councilman Paul Valentine**

---

**Councilman Daniel Sullivan**

---

**Councilman Brian Donohue**

---

**Supervisor Teresa M. Kenny**