

HANDICAP PARKING SPACE DETAIL

1/4" = 1'-0"

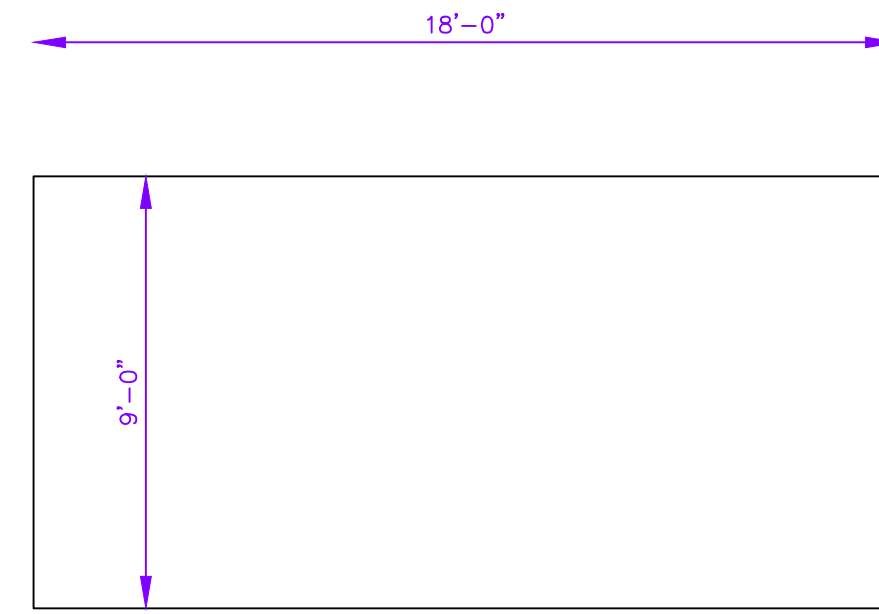

DIMENSIONS TYPICAL PARKING SPACE

1/4" = 1'-0"

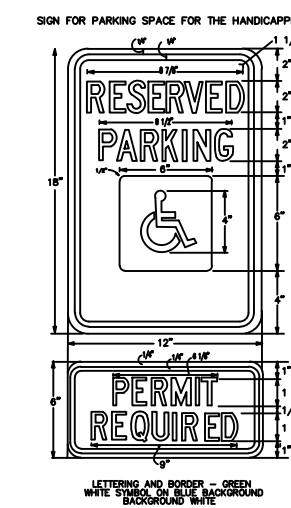

HANDICAP PARKING SIGN

NOT TO SCALE

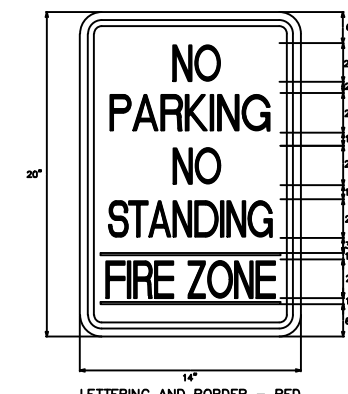

NO PARKING/NO STANDING/FIRE ZONE SIGN

NOT TO SCALE

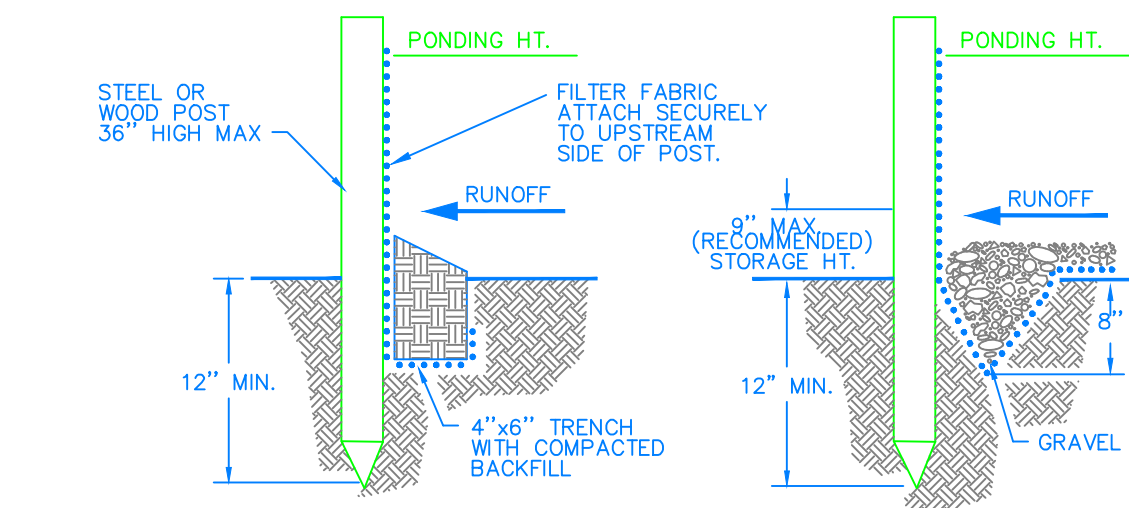
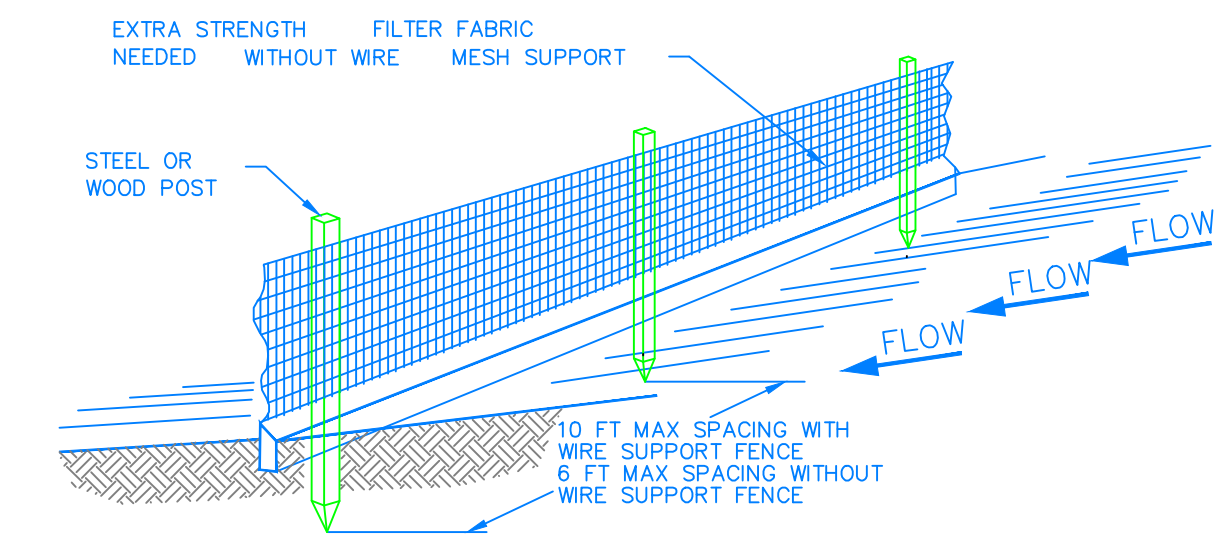

NOTE:
 1. INSPECT AND REPAIR FENCE AFTER EACH STORM EVENT AND REMOVE SEDIMENT WHEN NECESSARY.
 2. REMOVED SEDIMENT SHALL BE DEPOSITED TO AN AREA THAT WILL NOT CONTRIBUTE SEDIMENT OFF-SITE AND CAN BE PERMANENTLY STABILIZED.
 3. SILT FENCE SHALL BE PLACED ON SLOPE CONTOURS TO MAXIMIZE POUNDING EFFICIENCY.

SILT FENCE
n.t.s.

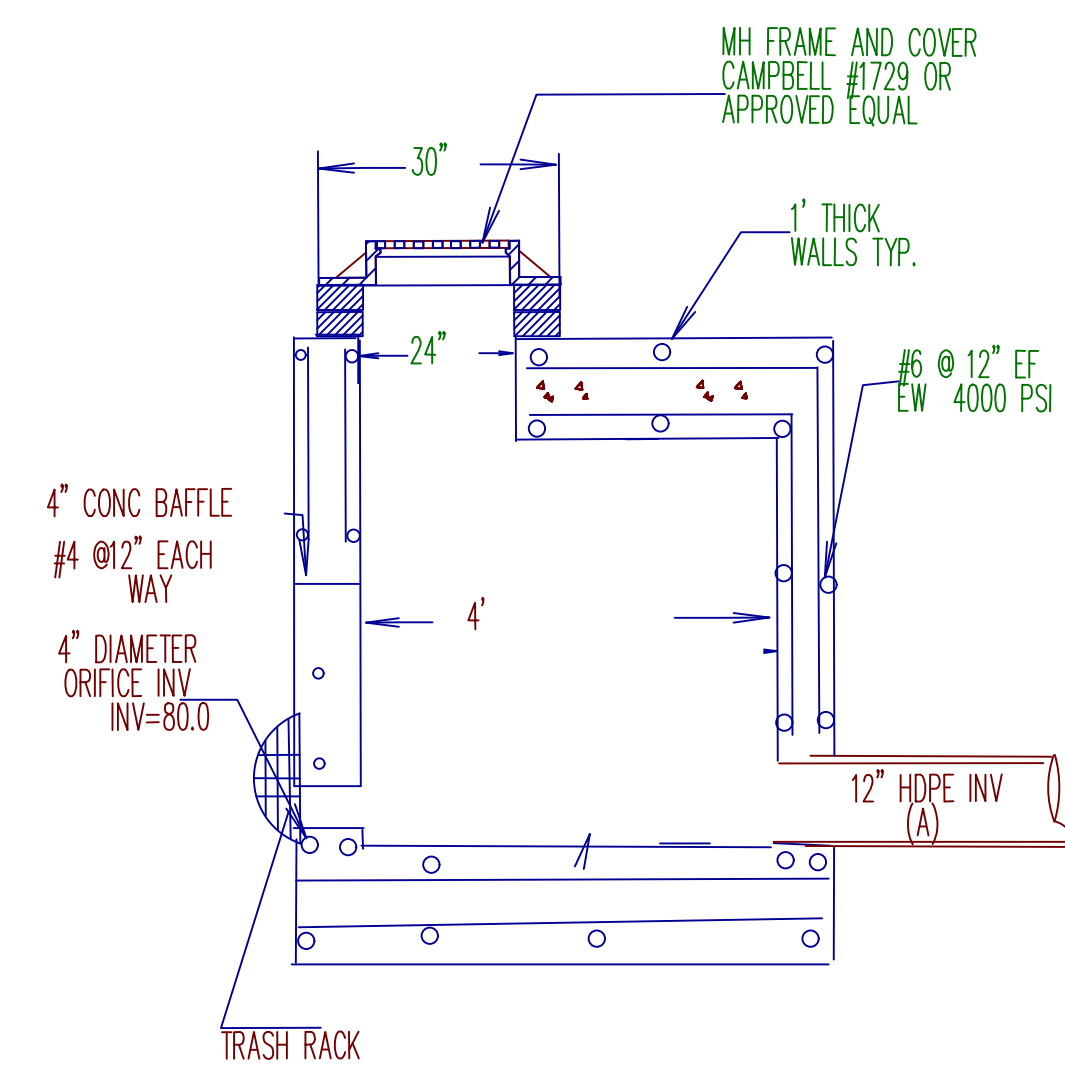
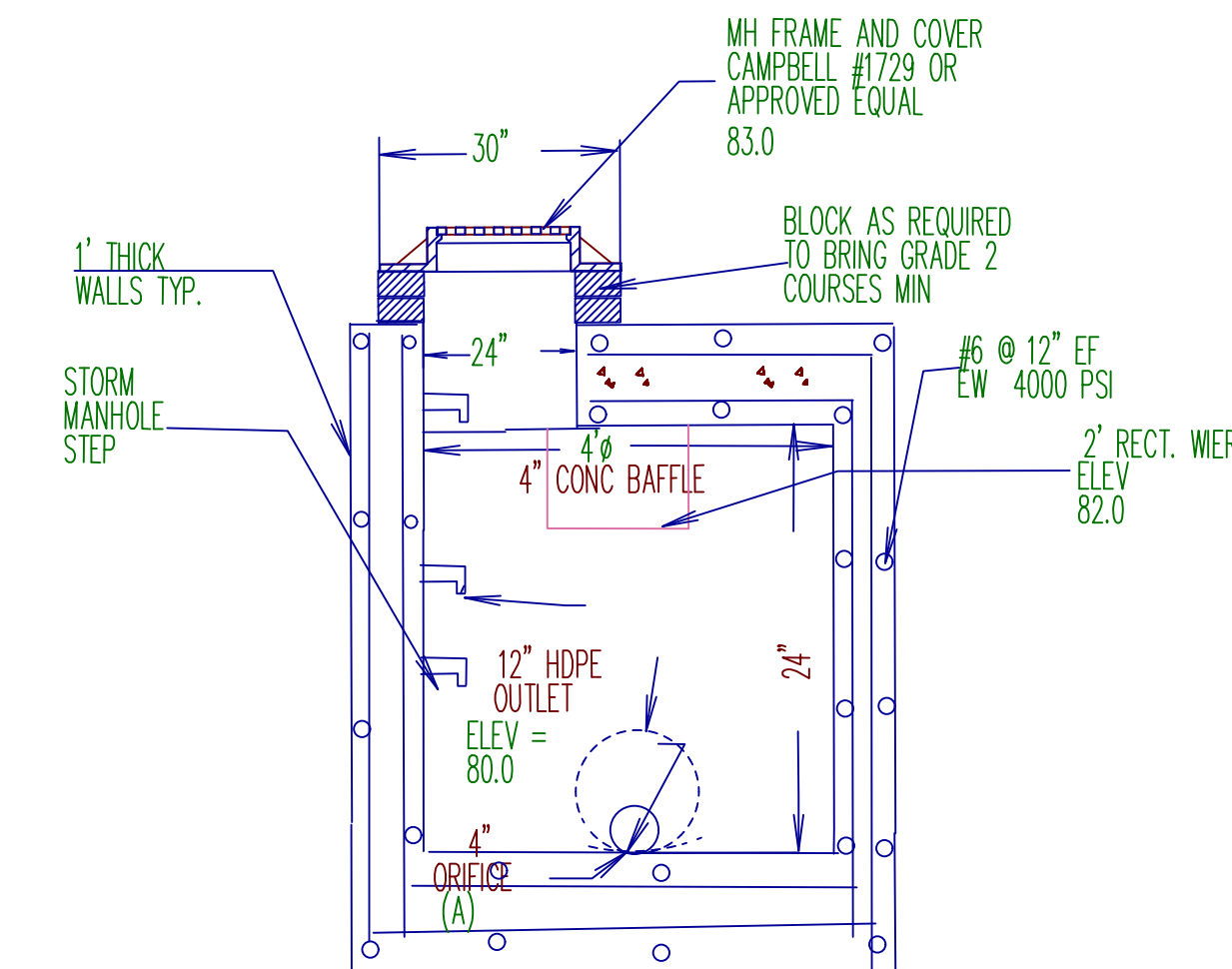

OUTLET STRUCTURE DETAIL

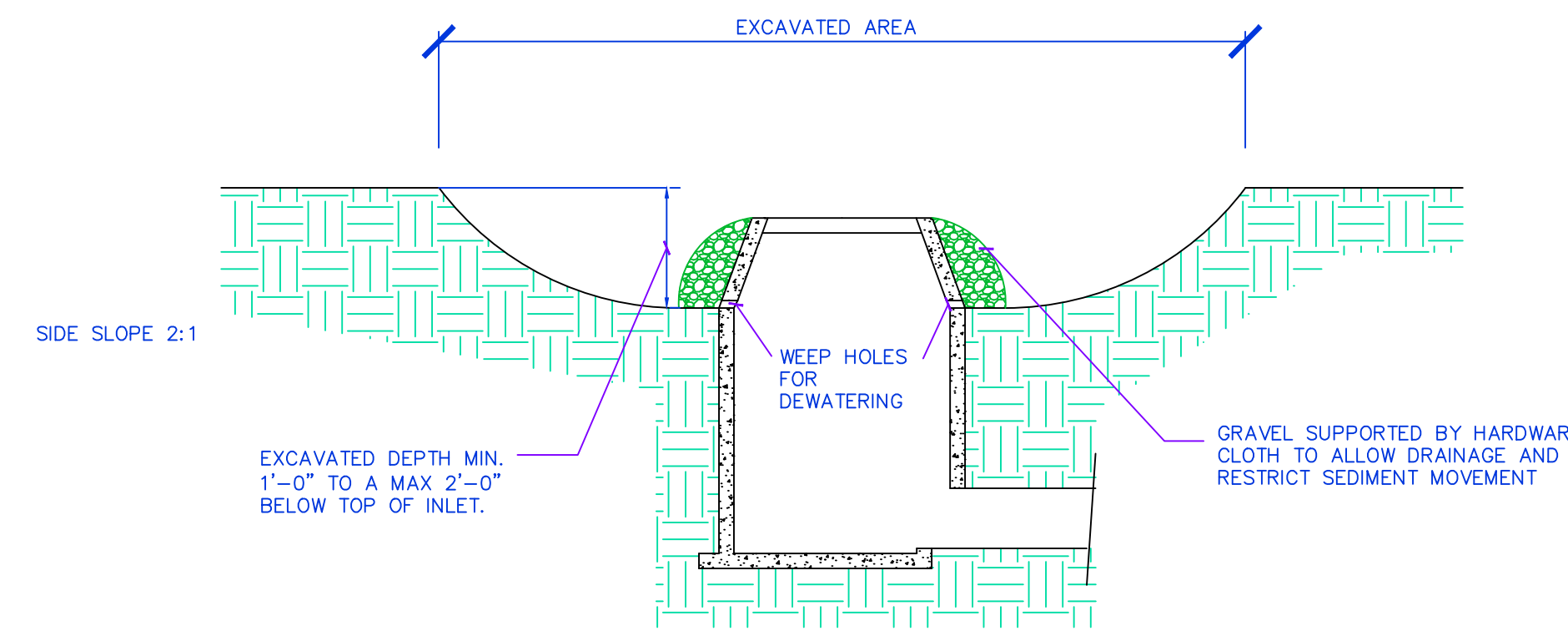

INLET PROTECTION

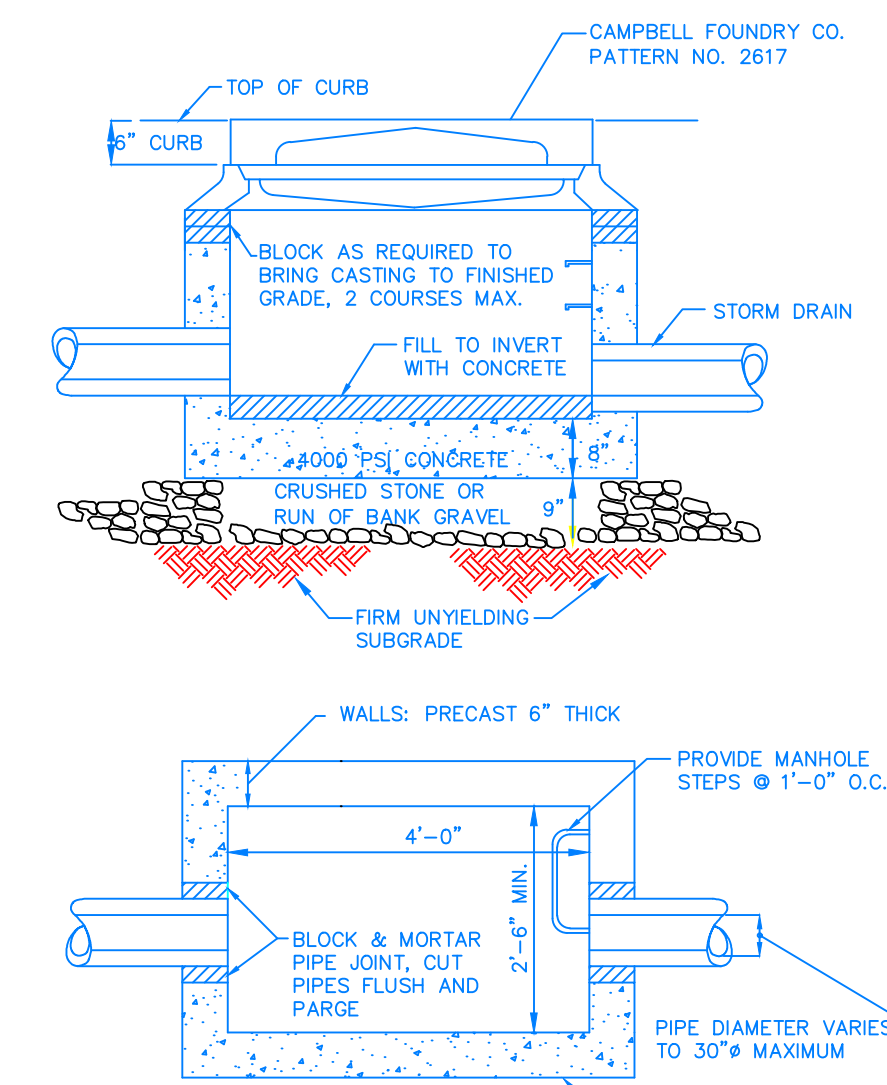

NOTE:
 MINIMUM STRENGTH CONCRETE 4000 PSI
 WALL THICKNESS 6" WITH ADEQUATE STEEL REINFORCEMENT TO WITHSTAND H20 HIGHWAY LOAD AND SOIL LOADS.

CATCH BASIN DETAIL

n.t.s.

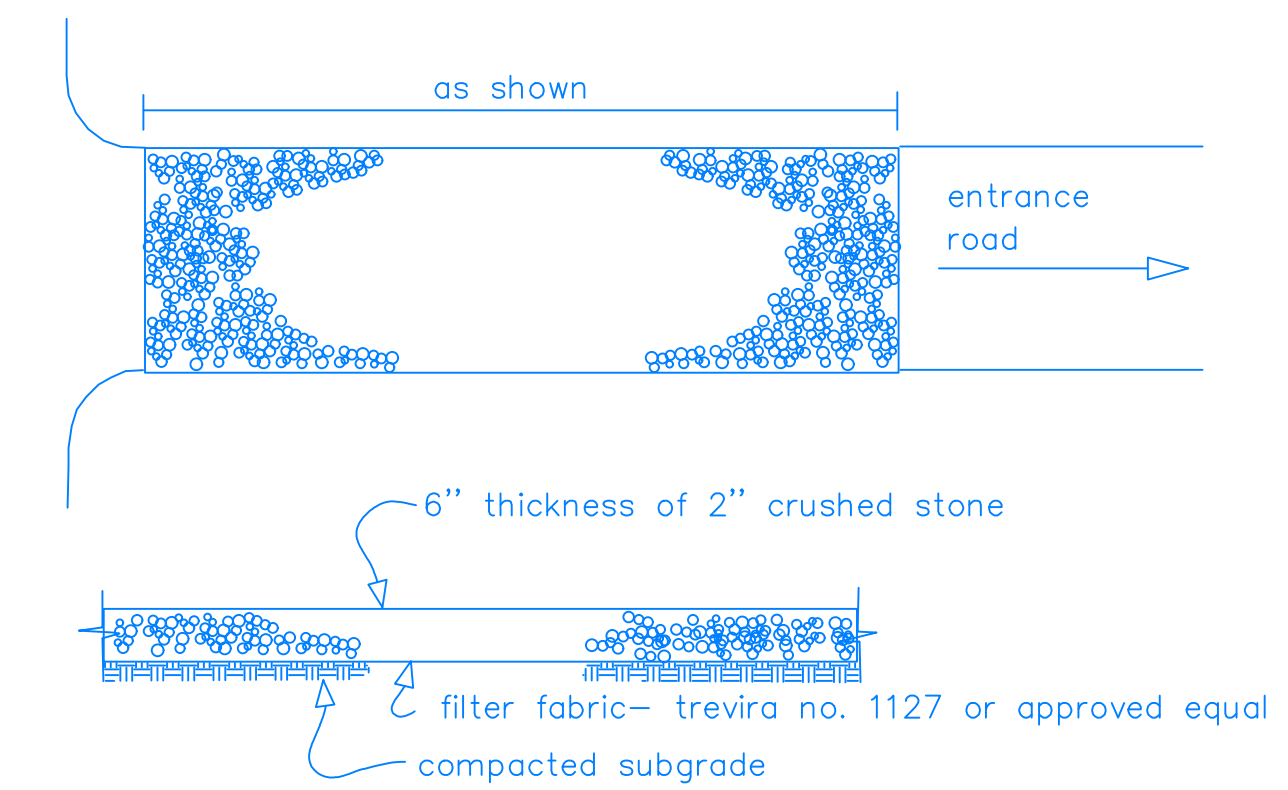

STABILIZED CONSTRUCTION ENTRANCE WHEEL CLEANING BLANKET

NOT TO SCALE

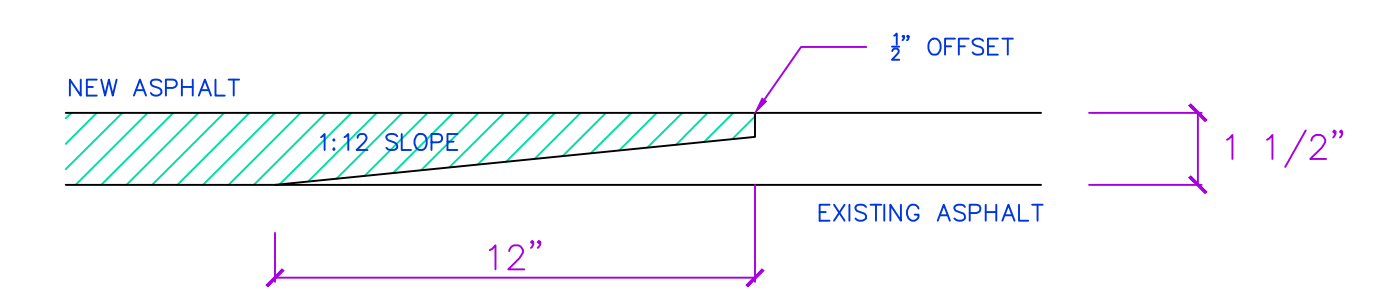

ASPHALT BUTTING DETAIL

REVISIONS:	

REVISIONS:	
DATE:	2 MAY 2023
SCALE:	AS NOTED
SHEET:	D-1

DATE:	20 OCTOBER 2022
SCALE:	AS NOTED
SHEET:	D-1

EAST COAST BLR 1993 LLC
 11 KINGS HIGHWAY
 TAPPAN, NEW YORK 10983

DO NOT SCALE PRINTS
 DETAILS

BART M. RODI - ENGINEER
 RESIDENTIAL & COMMERCIAL
 234 SOUTH GRANT AVE
 CONGERS, NEW YORK 10920
 (845) 268-6663

