

# SIGN INVENTORY

<b>SITE:</b>	SUB0217S Bill Kolb Jr Subaru	
<b>SIGN</b>	<b>PAGE</b>	<b>PROPOSED SIGN</b>
N01	7	53"h 2019 Chrome Logo - 39.8SF
N02	7	36"h 2019 "SUBARU" Chnl Ltrs - 69.4SF
N03	7	24"h "BILL KOLB JR" Chnl Ltrs - 43.67SF
N04	7	18"h "SERVICE" Chnl Ltrs - 15.5SF
N05	7	12"h "EXPRESS" Chnl Ltrs - 6.66SF
N06	2	P48 Pylon - 16' 4" OAH - 50.9SF
N07	3	M24 2019 Monument - 7' 4-7/8" OAH - 35.86SF
N08	4	M24 2019 Monument - 7' 4-7/8" OAH - 35.86SF. "Entrance"
<b>GRAND TOTAL AREA OF SIGNS - 297.65 SF</b>		
<b>NOTE: ALL SIGNS ARE INTERNALLY LED LIT</b>		

PLANNING BOARD  
MEETING OF:  
SEP 18 2023  
Town Of Orangetown

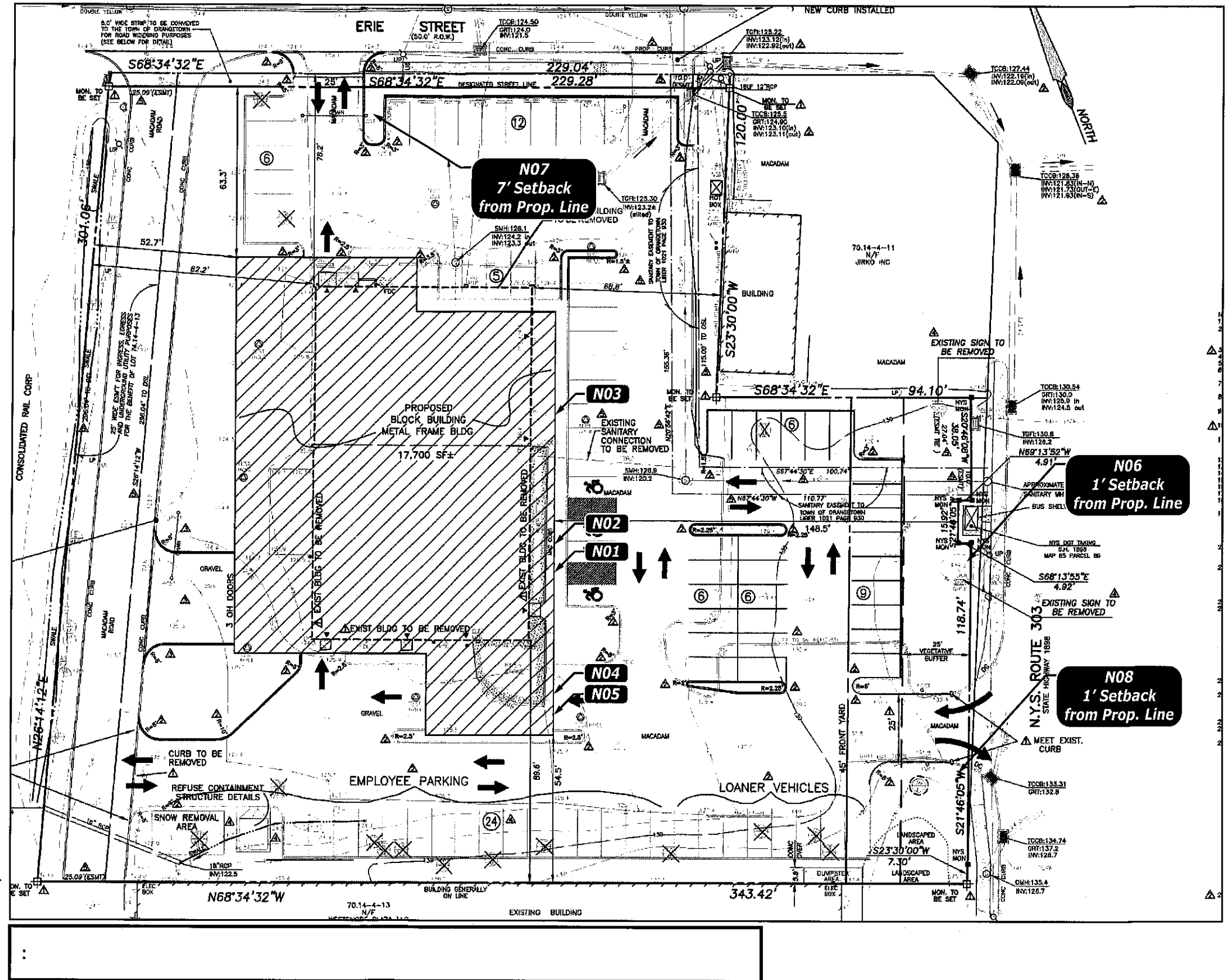

<b>PHILADELPHIASIGN</b> BRINGING THE WORLD'S BRANDS TO LIFE	TITLE	Subaru	DWG BY	JHH	DATE	02.15.18	DATE	03.14.18	REVISION	Revised N01-N05 & Added N07	BY	AFR	THIS IS AN ORIGINAL UNPUBLISHED DRAWING CREATED BY P.S.C.O. IT IS SUBMITTED FOR YOUR PERSONAL USE IN CONJUNCTION WITH A PROJECT BEING PLANNED FOR YOU BY P.S.C.O. IT IS NOT TO BE SHOWN TO ANYONE OUTSIDE YOUR ORGANIZATION NOR IS IT TO BE USED, COPIED, REPRODUCED, OR EXHIBITED IN ANY FASHION.
	ADDRESS	SUB02171S Bill Kolb Jr Subaru 582 Rt. 303 Orangeburg, NY 10962		DWG NUM	B77325		DATE	03.02.21	REVISION	Revised as Noted	BY	ZAS	
	SHEET	1		DATE	11.11.21	REVISION	Revised as Noted	BY	ZAS				
	DATE	09.30.22	REVISION	Revised as Noted	BY	AW							
			DATE	10.12.22	REVISION	Revised as Noted	BY	AW					
			DATE	04.13.23	REVISION	Revised N08	BY	AW					



**N06 - P48 2019 PYLON SIGN**  
Scale: 3/8" = 1' 0"

 <b>PHILADELPHIASIGN</b> BRINGING THE WORLD'S BRANDS TO LIFE	TITLE	Subaru	DWG BY	JHH	DATE	02.15.18	DATE	03.14.18	REVISION	Revised N01-N05 & Added N07	BY	AFR	THIS IS AN ORIGINAL UNPUBLISHED DRAWING CREATED BY P.S.C.O. IT IS SUBMITTED FOR YOUR PERSONAL USE IN CONJUNCTION WITH A PROJECT BEING PLANNED FOR YOU BY P.S.C.O. IT IS NOT TO BE SHOWN TO ANYONE OUTSIDE YOUR ORGANIZATION NOR IS IT TO BE USED, COPIED, REPRODUCED, OR EXHIBITED IN ANY FASHION.
	ADDRESS	SUB02171S Bill Kolb Jr Subaru		DWG NUM	B77325	DATE	03.02.21	REVISION	Revised as Noted	BY	ZAS		
		582 Rt. 303 Orangeburg, NY 10962		SHEET	2	DATE	11.11.21	REVISION	Revised as Noted	BY	ZAS		
					DATE	09.30.22	REVISION	Revised as Noted	BY	AW			
					DATE	10.12.22	REVISION	Revised as Noted	BY	AW			
					DATE	04.13.23	REVISION	Revised N08	BY	AW			

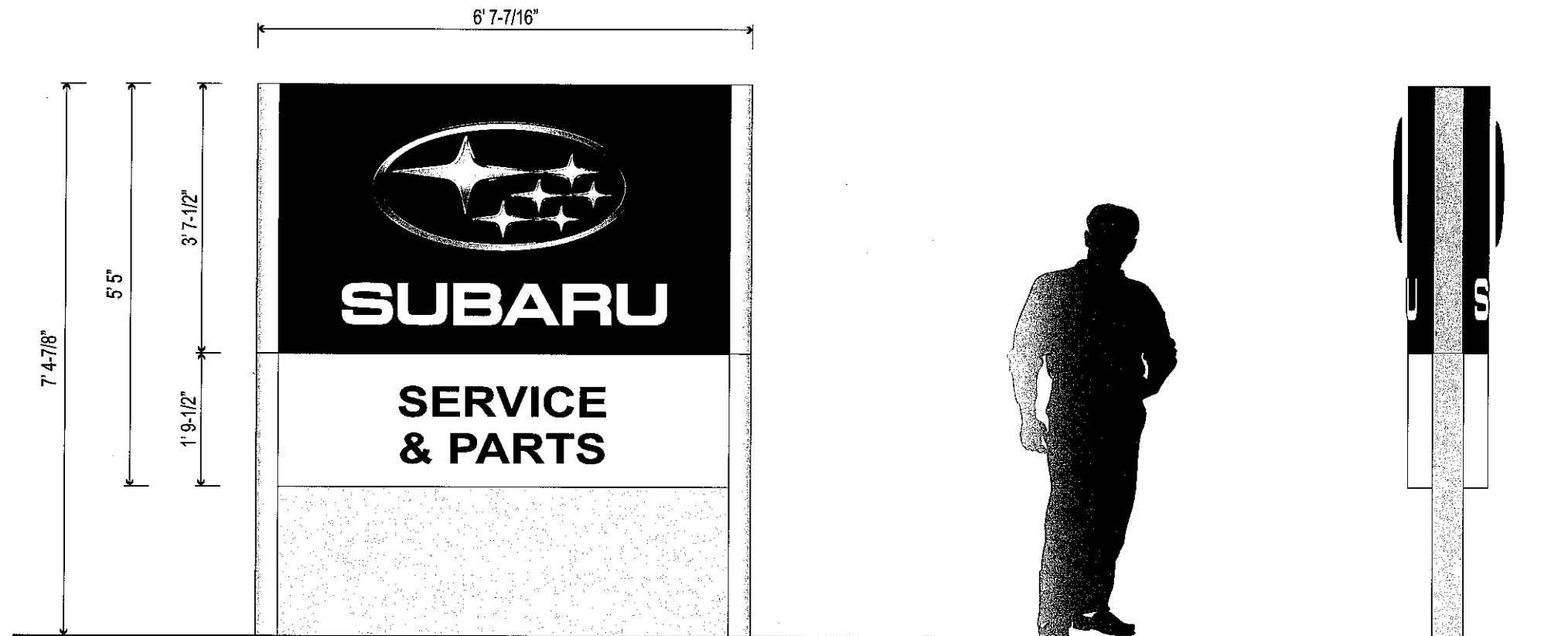

**N07 - M24 2019 MONUMENT SIGN**  
Scale: 1/2" = 1' 0"



**PHILADELPHIASIGN**  
BRINGING THE WORLD'S BRANDS TO LIFE

TITLE	Subaru	DWG BY	JHH	DATE	02.15.18	DATE	03.14.18	REVISION	Revised N01-N05 & Added N07	BY	AFR
ADDRESS	SUB02171S Bill Kolb Jr Subaru 582 Rt. 303 Orangeburg, NY 10962			DWG NUM	B77325	DATE	03.02.21	Revised as Noted		ZAS	
				SHEET	3	DATE	11.11.21	Revised as Noted		ZAS	
						DATE	09.30.22	Revised as Noted		AW	
						DATE	10.12.22	Revised as Noted		AW	
						DATE	04.13.23	Revised N08		AW	

THIS IS AN ORIGINAL UNPUBLISHED DRAWING CREATED BY P.S.C.O. IT IS SUBMITTED FOR YOUR PERSONAL USE IN CONJUNCTION WITH A PROJECT BEING PLANNED FOR YOU BY P.S.C.O. IT IS NOT TO BE SHOWN TO ANYONE OUTSIDE YOUR ORGANIZATION NOR IS IT TO BE USED, COPIED, REPRODUCED, OR EXHIBITED IN ANY FASHION.

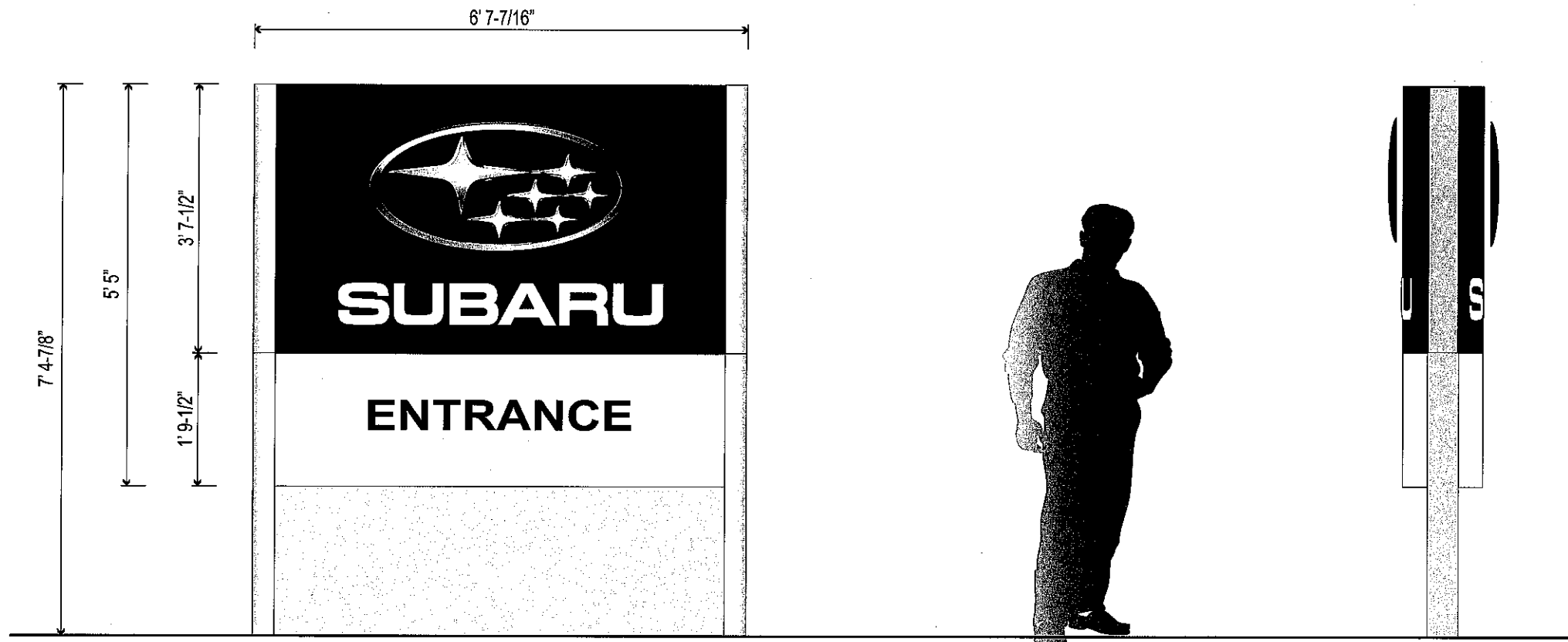

**N08 - M24 2019 MONUMENT SIGN**  
 Scale: 1/2" = 1' 0"

 <b>PHILADELPHIASIGN</b> BRINGING THE WORLD'S BRANDS TO LIFE	TITLE	Subaru	DWG BY	JHH	DATE	02.15.18	DATE	03.14.18	REVISION	Revised N01-N05 & Added N07	BY	AFR	THIS IS AN ORIGINAL UNPUBLISHED DRAWING CREATED BY P.S.C.O. IT IS SUBMITTED FOR YOUR PERSONAL USE IN CONJUNCTION WITH A PROJECT BEING PLANNED FOR YOU BY P.S.C.O. IT IS NOT TO BE SHOWN TO ANYONE OUTSIDE YOUR ORGANIZATION NOR IS IT TO BE USED, COPIED, REPRODUCED, OR EXHIBITED IN ANY FASHION.
	ADDRESS	SUB02171S Bill Kolb Jr Subaru 582 Rt. 303 Orangeburg, NY 10962			DWG NUM	B77325	DATE	03.02.21	REVISION	Revised as Noted	BY	ZAS	
					SHEET	4	DATE	11.11.21	REVISION	Revised as Noted	BY	ZAS	
							DATE	09.30.22	REVISION	Revised as Noted	BY	AW	
						DATE	10.12.22	REVISION	Revised as Noted	BY	AW		
						DATE	04.13.23	REVISION	Revised N08	BY	AW		

N06 P48 Double Faced Pylon - 16' 4"oah (50.9 Sq Ft)  
 N08 M24 2019 Double Faced Monument - 7' 4-7/8"oah (35.86 Sq Ft)

Existing



Proposed



Route 303 Elevation

**DIMENSIONS TO BE FIELD VERIFIED**

 <b>PHILADELPHIASIGN</b> BRINGING THE WORLD'S BRANDS TO LIFE	TITLE	Subaru	DWG BY	JHH	DATE	02.15.18	DATE	03.14.18	REVISION	BY	THIS IS AN ORIGINAL UNPUBLISHED DRAWING CREATED BY P.S.C.O. IT IS SUBMITTED FOR YOUR PERSONAL USE IN CONJUNCTION WITH A PROJECT BEING PLANNED FOR YOU BY P.S.C.O. IT IS NOT TO BE SHOWN TO ANYONE OUTSIDE YOUR ORGANIZATION NOR IS IT TO BE USED, COPIED, REPRODUCED, OR EXHIBITED IN ANY FASHION.
	ADDRESS	SUB02171S Bill Kolb Jr Subaru 582 Rt. 303 Orangeburg, NY 10962		DWG NUM	B77325		DATE	03.02.21	Revised as Noted	AFR	
	SHEET	5		DATE	11.11.21	Revised as Noted	ZAS	09.30.22	Revised as Noted	AW	
					DATE	10.12.22	DATE	04.13.23	Revised as Noted	AW	
									Revised N08	AW	

Proposed



Erie Street Elevation

**DIMENSIONS TO BE FIELD VERIFIED**

Existing

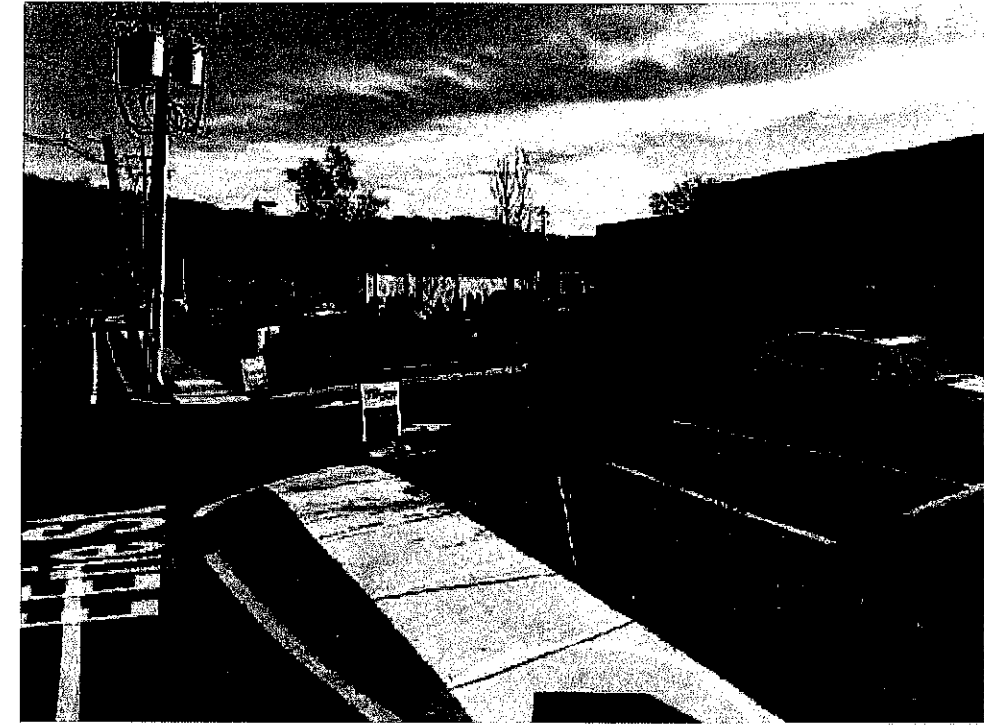

TITLE	Subaru	DWG BY	JHH	DATE	02.15.18	DATE	03.14.18	REVISION	Revised N01-N05 & Added N07.....	BY	AFR
ADDRESS	SUB02171S Bill Kolb Jr Subaru 582 Rt. 303 Orangeburg, NY 10962			DWG NUM	B77325	DATE	03.02.21	Revised as Noted.....		ZAS	
				SHEET	6	DATE	11.11.21	Revised as Noted.....		ZAS	
						DATE	09.30.22	Revised as Noted.....		AW	
						DATE	10.12.22	Revised as Noted.....		AW	
						DATE	04.13.23	Revised N08.....		AW	

THIS IS AN ORIGINAL UNPUBLISHED DRAWING CREATED BY P.S.C.O. IT IS SUBMITTED FOR YOUR PERSONAL USE IN CONJUNCTION WITH A PROJECT BEING PLANNED FOR YOU BY P.S.C.O. IT IS NOT TO BE SHOWN TO ANYONE OUTSIDE YOUR ORGANIZATION NOR IS IT TO BE USED, COPIED, REPRODUCED, OR EXHIBITED IN ANY FASHION.



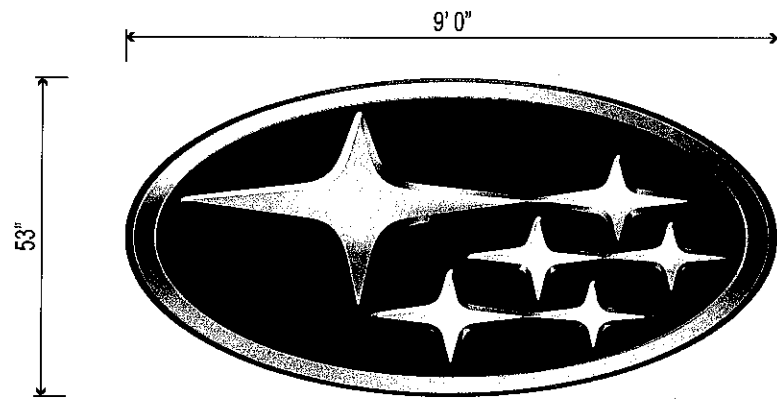

**N01 - 53" 2019 ILLUM LOGO**  
Scale: 3/8" = 1' 0"

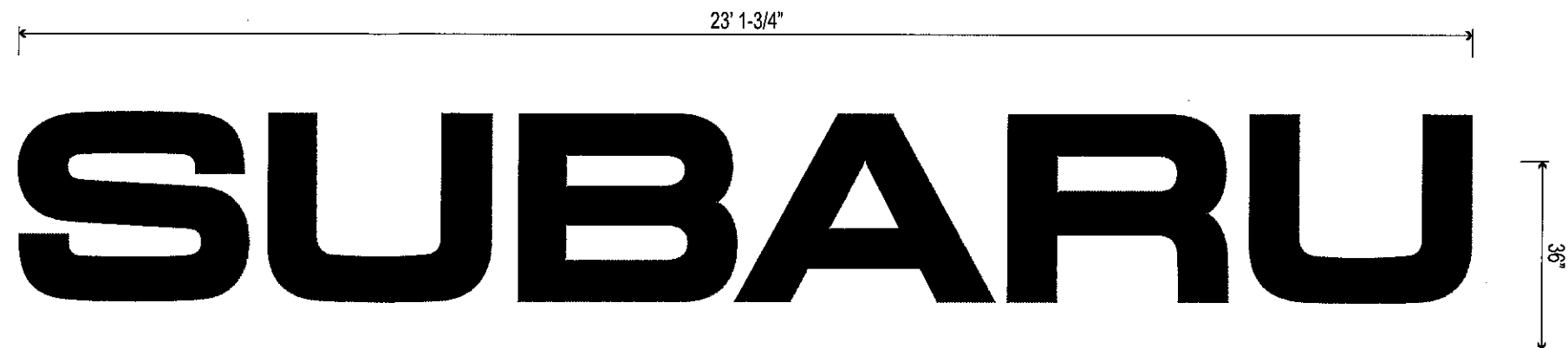

**N02 - 36" 2019 ILLUM CHANNEL LETTERS**  
Scale: 3/8" = 1' 0"

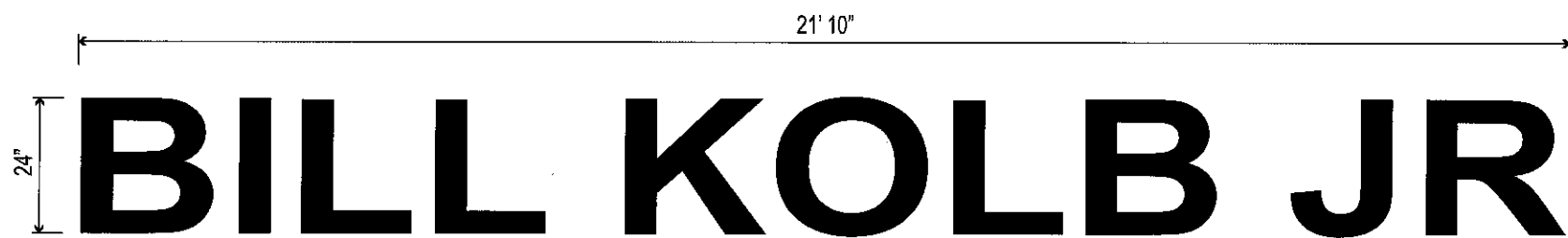

**N03 - 24" ILLUM CHANNEL LETTER**  
Scale: 3/8" = 1' 0"

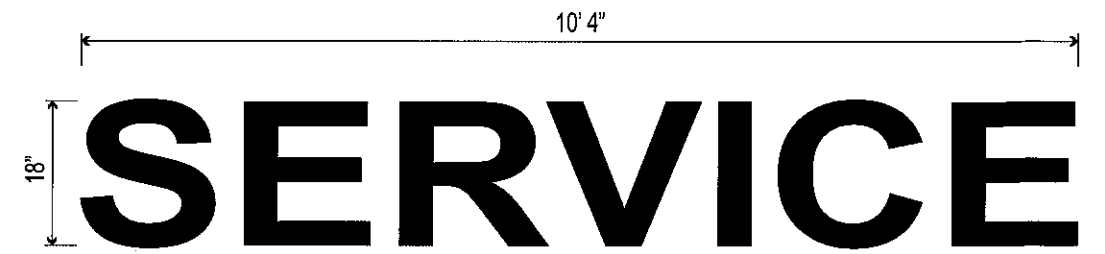

**N04 - 18" ILLUM CHANNEL LETTER**  
Scale: 1/2" = 1' 0"



**N05 - 12" ILLUM CHANNEL LETTER**  
Scale: 3/4" = 1' 0"

NOTE: Interior wireways &/or exterior parapet raceways are an extra cost where applicable to conceal or otherwise house letter to letter wiring & power supplies for illuminated letters &/or logos.

 <b>PHILADELPHIASIGN</b> BRINGING THE WORLD'S BRANDS TO LIFE	TITLE	Subaru	DWG BY	JHH	DATE	02.15.18	DATE	03.14.18	REVISION	BY	THIS IS AN ORIGINAL UNPUBLISHED DRAWING CREATED BY P.S.C.O. IT IS SUBMITTED FOR YOUR PERSONAL USE IN CONJUNCTION WITH A PROJECT BEING PLANNED FOR YOU BY P.S.C.O. IT IS NOT TO BE SHOWN TO ANYONE OUTSIDE YOUR ORGANIZATION NOR IS IT TO BE USED, COPIED, REPRODUCED, OR EXHIBITED IN ANY FASHION.
	ADDRESS	SUB02171S Bill Kolb Jr Subaru 582 Rt. 303 Orangeburg, NY 10962		DWG NUM	B77325	DATE	03.02.21	Revised as Noted	AFR		
				SHEET	8	DATE	11.11.21	Revised as Noted	ZAS		
						DATE	09.30.22	Revised as Noted	ZAS		
						DATE	10.12.22	Revised as Noted	AW		
						DATE	04.13.23	Revised N08	AW		



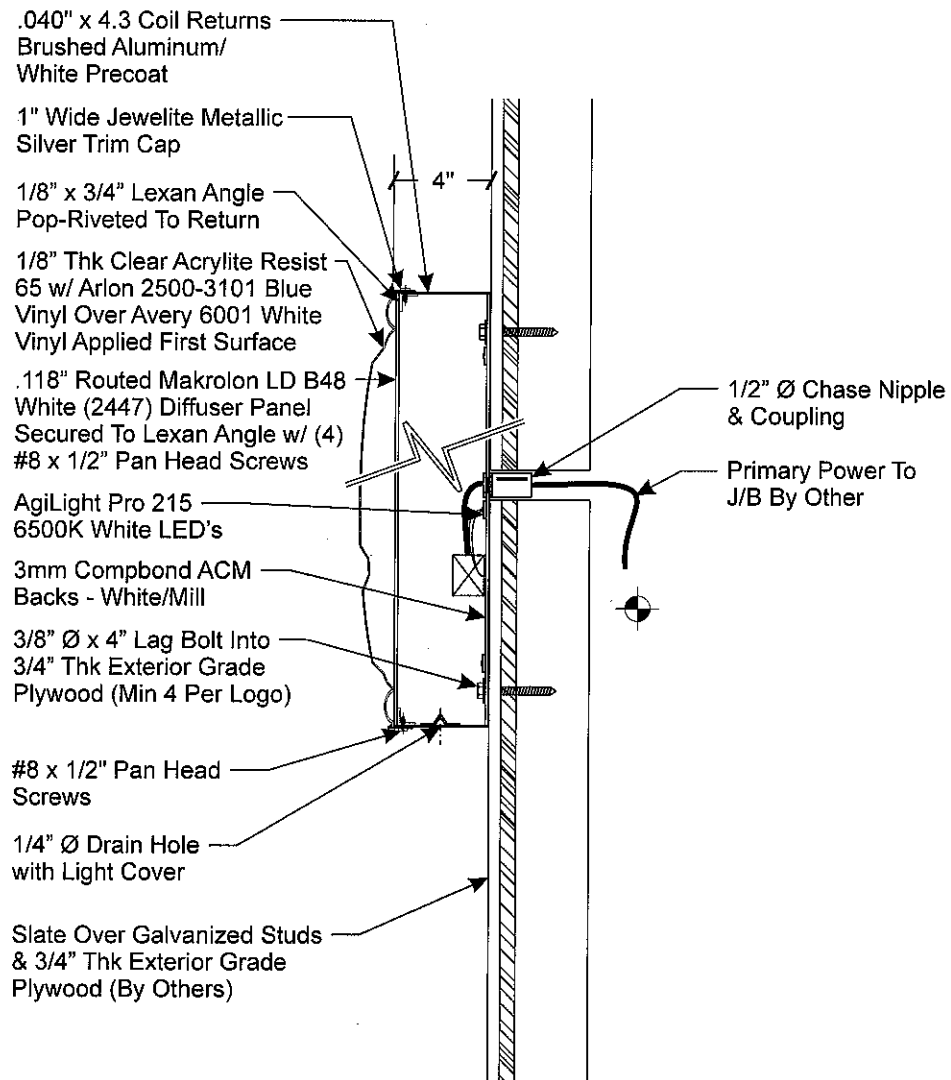

**LOGO CROSS SECTION**  
SCALE: 1 1/2" = 1'-0"

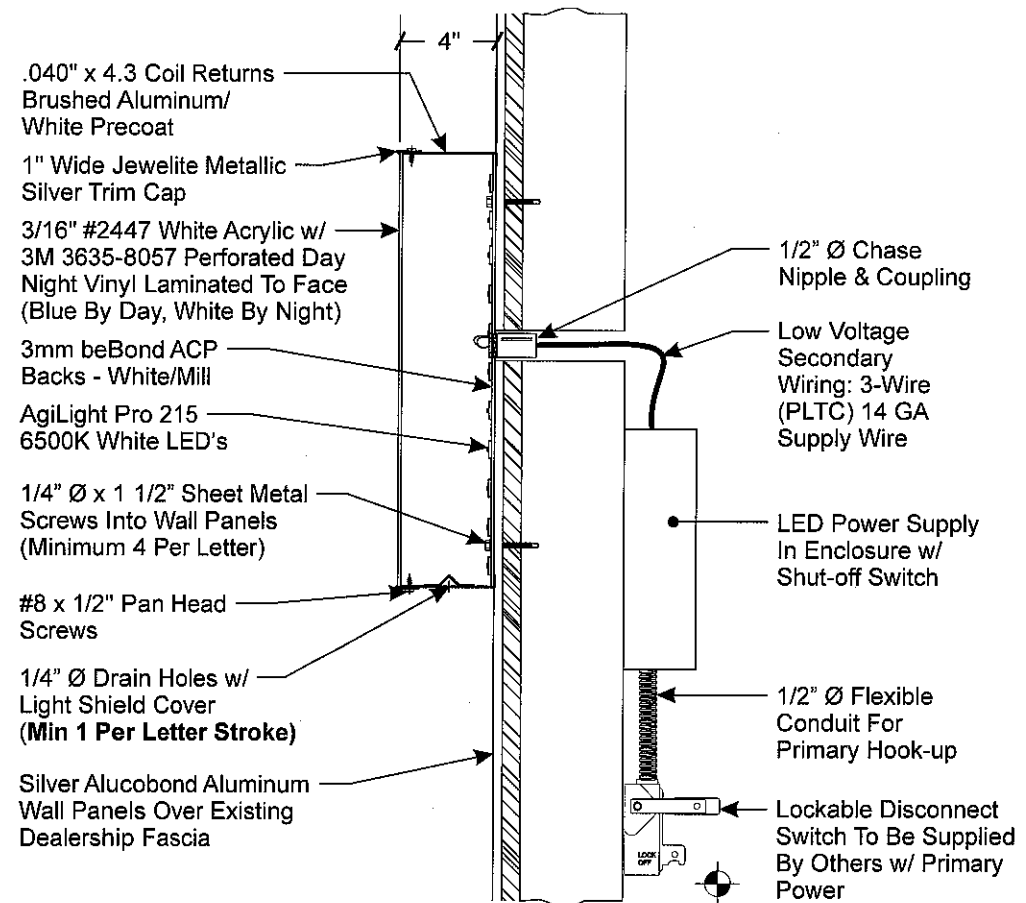

**LETTER CROSS SECTION**  
SCALE: 1 1/2" = 1'-0"

**ELECTRICAL LOAD**  
3.0 Amps @ 120 Volts  
**ELECTRICAL REQ'MTS**  
(1) 20 Amp/120 Volt Circuit

**ELECTRICAL LOAD**  
2.0 Amps @ 120 Volts  
**ELECTRICAL REQ'MTS**  
(1) 20 Amp/120 Volt Circuit

**STANDARD WALL SIGN NOTES:**  
1. Sufficient Primary Circuit In Vicinity Of Sign By Others.  
2. Final Primary Hook-up By Sign Installer, Where Allowed By Local Codes.  
3. Sign Shall Be U.L. Listed.  
4. Mounting Hardware By Sign Installer.

**STANDARD LETTER NOTES:**  
1. Sufficient Primary Circuit In Vicinity Of Sign By Others.  
2. Letter To Letter Wiring & Final Primary Hook-up By Sign Installer, Where Allowed By Local Codes.  
3. Sign Shall Be U.L. Listed.  
4. Mounting Hardware By Sign Installer.  
5. Full Size Drilling Template Furnished With Sign.  
6. This Sign has been Designed with the Criteria as set forth in the IBC 2003 & IBC 2006. The Design Meets or Exceeds those Requirements for the Geographical Location in Which it is to be Erected.



TITLE	Subaru	DWG BY	JHH	DATE	02.15.18
ADDRESS	SUB02171S Bill Kolb Jr Subaru 582 Rt. 303 Orangeburg, NY 10962		DWG NUM	B77325	
		SHEET	9		

DATE	03.14.18	REVISION	Revised N01-N05 & Added N07	BY	AFR
	03.02.21		Revised as Noted		ZAS
	11.11.21		Revised as Noted		ZAS
	09.30.22		Revised as Noted		AW
	10.12.22		Revised as Noted		AW
	04.13.23		Revised N08		AW

THIS IS AN ORIGINAL UNPUBLISHED DRAWING CREATED BY P.S.C.O. IT IS SUBMITTED FOR YOUR PERSONAL USE IN CONJUNCTION WITH A PROJECT BEING PLANNED FOR YOU BY P.S.C.O. IT IS NOT TO BE SHOWN TO ANYONE OUTSIDE YOUR ORGANIZATION NOR IS IT TO BE USED, COPIED, REPRODUCED, OR EXHIBITED IN ANY FASHION.

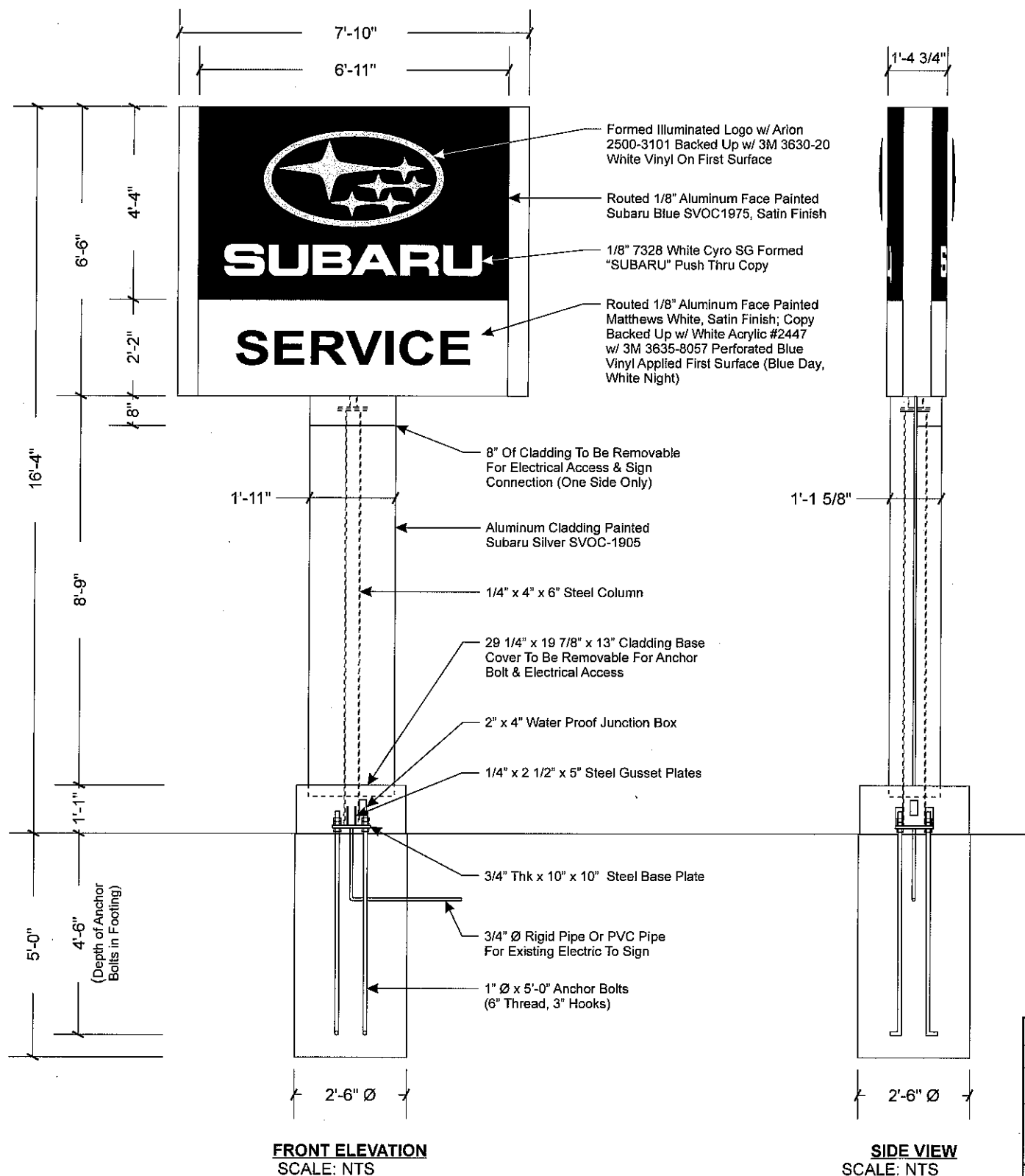

Note: This sign is intended to be installed in accordance with the requirements of Article 600 of the National Electrical Code and/or other applicable local codes. This includes proper grounding and bonding of the sign.

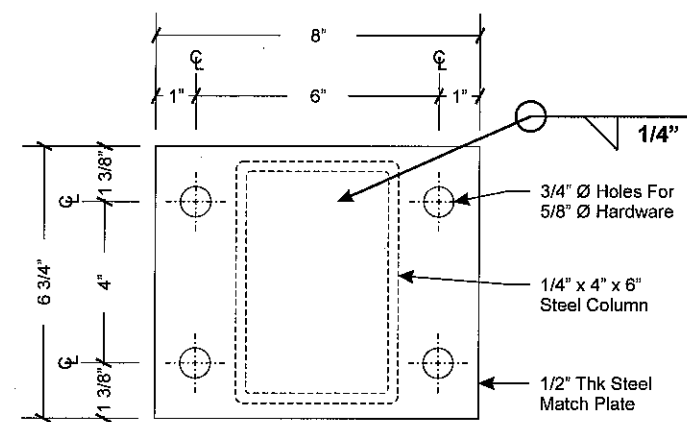

**MATCH PLATE DETAIL**  
SCALE: NTS

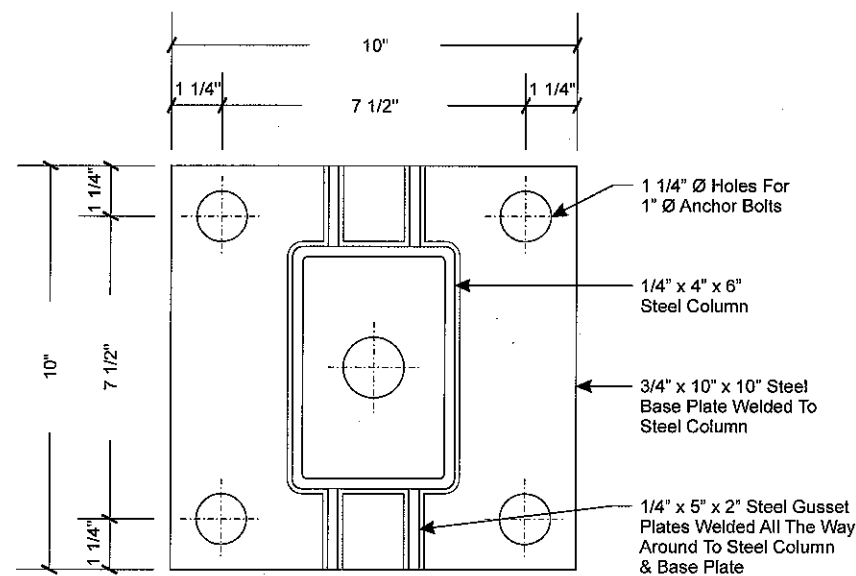

**BASE PLATE DETAIL**  
SCALE: NTS

**Electrical Load**  
2.32 Amps @ 120 Volts  
**Electrical Req'mts**  
(1) 20 Amp/120 Volt Circuits

HARDWARE LIST		
Description	Hardware	Qty
Match Plate Hardware	5/8" Ø x 3" Lg Hex Bolts w/ Nuts & (2) Flat (1) Lock Washer Per Bolt	4
Anchor Bolt Hardware	1" Ø x 5'-0" Lg Bolt 6" Thread / 3" Hook (3) Nuts (2) Flat Washers Per Bolt	4

Note: Unless Otherwise Noted  
 - All Hardware to be SAE J429 - Grade 2  
 - All Anchor Bolts to be ANC F1554-GR55 - Grade 55  
 - All Anchor Bolt Nuts to be Heavy Hex Nuts A563A  
 - All Anchor Bolt Washers to be F844

- STANDARD PYLON NOTES:**
- Sufficient Primary Circuit In Vicinity Of Sign By Others.
  - Final Primary Hook-up By Sign Installer, Where Allowed By Local Codes.
  - Sign Shall Be U.L. Listed.
  - Soil Assumed To Be Medium Clay, Or Better, With Minimum Soil Bearing Capacity Of 2,500 PSF.
  - Concrete 2,500 PSI @ 28 Days.
  - Reinforcing Steel Shall Be ASTM A615 GR-40.
  - Structural Steel Shall Be ASTM A36.
  - All Welds Shall Conform To A.W.S Standards.



TITLE	Subaru	DWG BY	JHH	DATE	02.15.18
ADDRESS	SUB02171.1 Bill Kolb Jr Subaru 582 Rt. 303 Orangeburg, NY 10962			DWG NUM	B77325
				SHEET	10

DATE	03.06.18	REVISION	Added N06	BY	JHH
------	----------	----------	-----------	----	-----

THIS IS AN ORIGINAL UNPUBLISHED DRAWING CREATED BY P.S.C.O. IT IS SUBMITTED FOR YOUR PERSONAL USE IN CONJUNCTION WITH A PROJECT BEING PLANNED FOR YOU BY P.S.C.O. IT IS NOT TO BE SHOWN TO ANYONE OUTSIDE YOUR ORGANIZATION NOR IS IT TO BE USED, COPIED, REPRODUCED, OR EXHIBITED IN ANY FASHION.

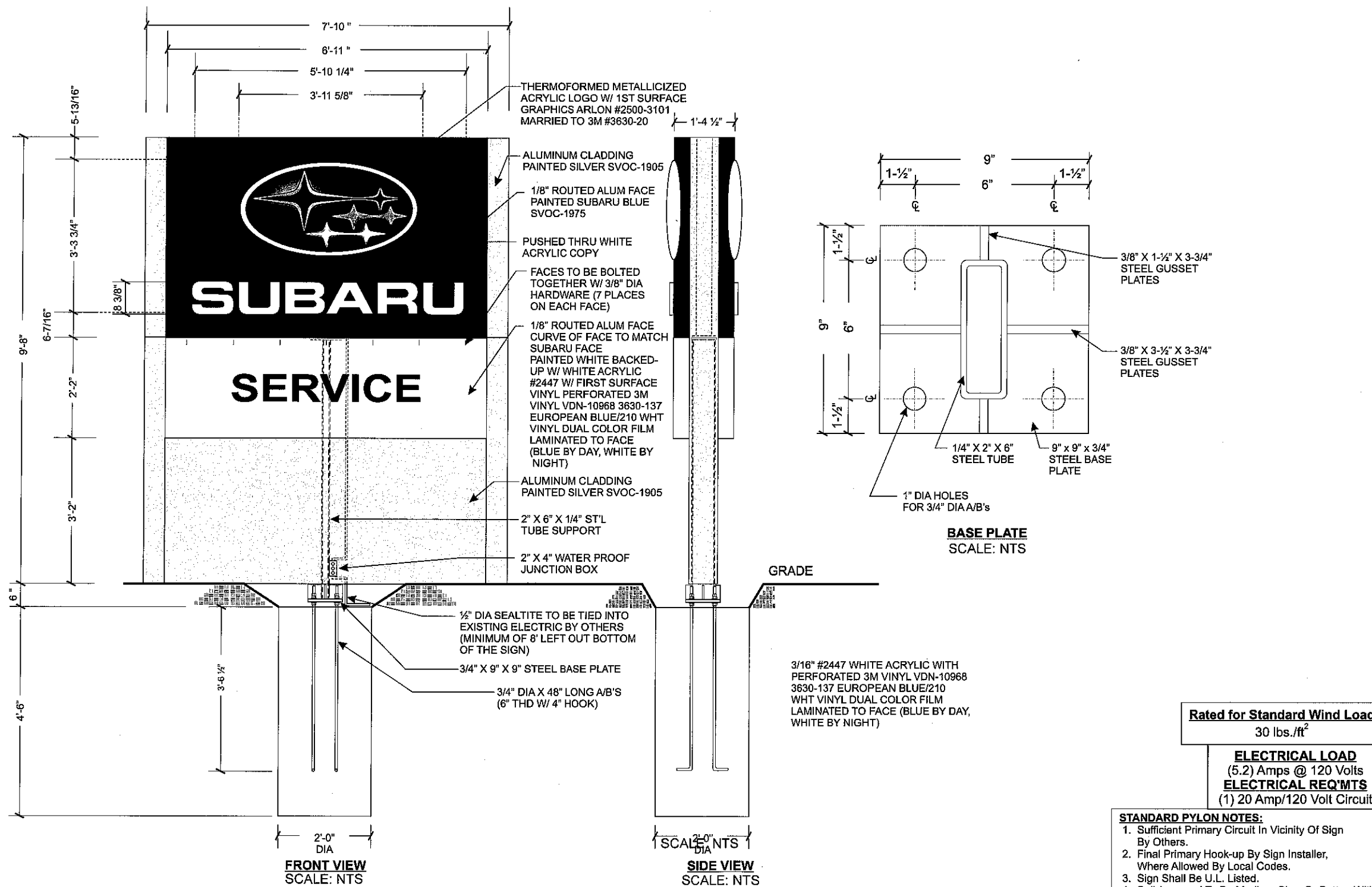

**Rated for Standard Wind Load**  
30 lbs./ft<sup>2</sup>

**ELECTRICAL LOAD**  
(5.2) Amps @ 120 Volts  
**ELECTRICAL REQ'MTS**  
(1) 20 Amp/120 Volt Circuit

- STANDARD PYLON NOTES:**
1. Sufficient Primary Circuit In Vicinity Of Sign By Others.
  2. Final Primary Hook-up By Sign Installer, Where Allowed By Local Codes.
  3. Sign Shall Be U.L. Listed.
  4. Soil Assumed To Be Medium Clay, Or Better, With Minimum Soil Bearing Capacity Of 2,500 PSF.
  5. Concrete 3,000 PSI @ 28 Days.
  6. Reinforcing Steel Shall Be ASTM A615 GR-40.
  7. Structural Steel Shall Be ASTM A36.
  8. All Welds Shall Conform To A.W.S Standards.



TITLE	Subaru	DWG BY	JHH	DATE	02.15.18
ADDRESS	SUB02171.1 Bill Kolb Jr Subaru 582 Rt. 303 Orangeburg, NY 10962		DWG NUM	B77325	
			SHEET	11	

DATE	03.06.18	REVISION	Added N06	BY	JHH
	03.14.18		Revised N01-N05 & Added N07		AFR

THIS IS AN ORIGINAL UNPUBLISHED DRAWING CREATED BY P.S.C.O. IT IS SUBMITTED FOR YOUR PERSONAL USE IN CONJUNCTION WITH A PROJECT BEING PLANNED FOR YOU BY P.S.C.O. IT IS NOT TO BE SHOWN TO ANYONE OUTSIDE YOUR ORGANIZATION NOR IS IT TO BE USED, COPIED, REPRODUCED, OR EXHIBITED IN ANY FASHION.