

PROJECT NAME: 59 TWEED BLVD

PROJECT ARCHITECT: IKE KLIGERMAN BARKLEY
 STRUCTURAL ENGINEER: DOMINICK R.PILLA ASSOCIATES PC

PROJECT ADDRESS: 59 TWEED BLVD, NYACK, NY 10960

Ike Kligerman Barkley
 330 West Forty-Second Street
 New York, NY 10096
 212 268 0128

ISSUED: FOR PERMIT

STRUCTURAL PLANS

DATE: 08/17/2021

INDEX OF DRAWINGS			
PAGE #	DWG #	REVISION #	DRAWING TITLE
1	S-001	00	TITLE SHEET
2	S-002	00	GENERAL NOTES
3	S-300	00	RETAINING WALL PLAN
4	S-400	00	RETAINING WALL SECTIONS
5	S-410	00	RETAINING WALL DETAILS

SYMBOL LEGEND	
	SECTION SYMBOL
	DETAIL REFERENCE SYMBOL
	ELEVATION REFERENCE SYMBOL
	PLAN, SECTION, OR DETAIL TITLE SYMBOL
	ELEVATION SYMBOL
	BEAM MOMENT CONNECTION
	POST UP/POST DOWN
LT-#	PRECAST LINTEL
GB-#	CONCRETE GRADE BEAM
F-#	FOOTING NUMBER
MW-#	MASONRY WALL NUMBER
CB-#	CONCRETE BEAM
CP-#	CONCRETE PIER
CW-#	CONCRETE WALL NUMBER

ABBREVIATION	
AESS	ARCHITECTURALLY EXPOSED STRUCTURAL STEEL
B	BOTTOM REINFORCEMENT
BM	BEAM
BS	BOTH SIDES
BU	BUILT UP MEMBER
BW	BEARING WALL
C	COMPRESSION FORCE IN KIPS
CANT.	CANTILEVER
CL	CENTER LINE
CG	CENTER OF GRAVITY
COL	COLUMN
CONT	CONTINUOUS
COMP LAP	COMPRESSION REINF LAP SLICE
CP	COMPLETE PENETRATION WELD
DB	DEVELOPMENT LENGTH OF REINFORCEMENT BAR
DEL	DELTA OR CHANGE IN ELEVATION
(E)	EXISTING CONSTRUCTION
EF	EACH FACE
EL	ELEVATION
EW	EACH WAY
F	FINISHED SURFACE
GB	GRADE BEAM
H	HORIZONTAL REINFORCEMENT
H	HORIZONTAL FORCE IN KIPS
HLJ2	NEW CODE FORMED STEEL JOISTS
LAP	FULL TENSION CAPACITY LAP SPLICE
LD	TENSION DEVELOPMENT LENGTH FOR REINFORCING BARS
LDC	COMPRESSION SPLICE LENGTH FOR REINFORCEMENT BARS
LLBB	LONG LEGS BACK-TO-BACK
LW	LIGHTWEIGHT CONCRETE
M	BENDING MOMENT IN FOOT-KIPS
MC	MOMENT CONNECTION SHOWN ON DRAWING
MIN	MINIMUM
(N)	NEW CONSTRUCTION
N	BEARING BOLTS THREADS INCLUDED IN SHEAR PLANE
NTS	NOT TO SCALE
OC	ON CENTER
PC	PILE CAP
PL	PLATE
PP	PARTIAL PENETRATION WELD
PL	PROPERTY LINE
SAD	SEE ARCHITECTURAL DRAWINGS/DETAILS
S1,S2	SLAB ON DECK TYPE
SC	SLIP CRITICAL BOLT
SIM	SIMILAR
SPW	SOLDIER PILE LAGGING WALL
SW	SHEAR WALL
T	TENSION FORCE IN KIPS
T	THICKNESS
T	TOP REINFORCEMENT
TBC	TO BE CONFIRMED
TOC	TOP OF CONCRETE
TOP	TOP OF FOOTING
TOS	TOP OF STEEL
TYP	TYPICAL
UNO,UON	UNLESS OTHERWISE NOTED
M	MOMENT
V	VERTICAL BEAM END REACTION IN KIPS
VIF	VERIFY IN FIELD
WP	WORKPOINT
WWF	WELDED WIRE FABRIC

LEGEND	
	NEW CONCRETE RETAINING WALL
	NEW FOOTING
	PROPERTY LINE

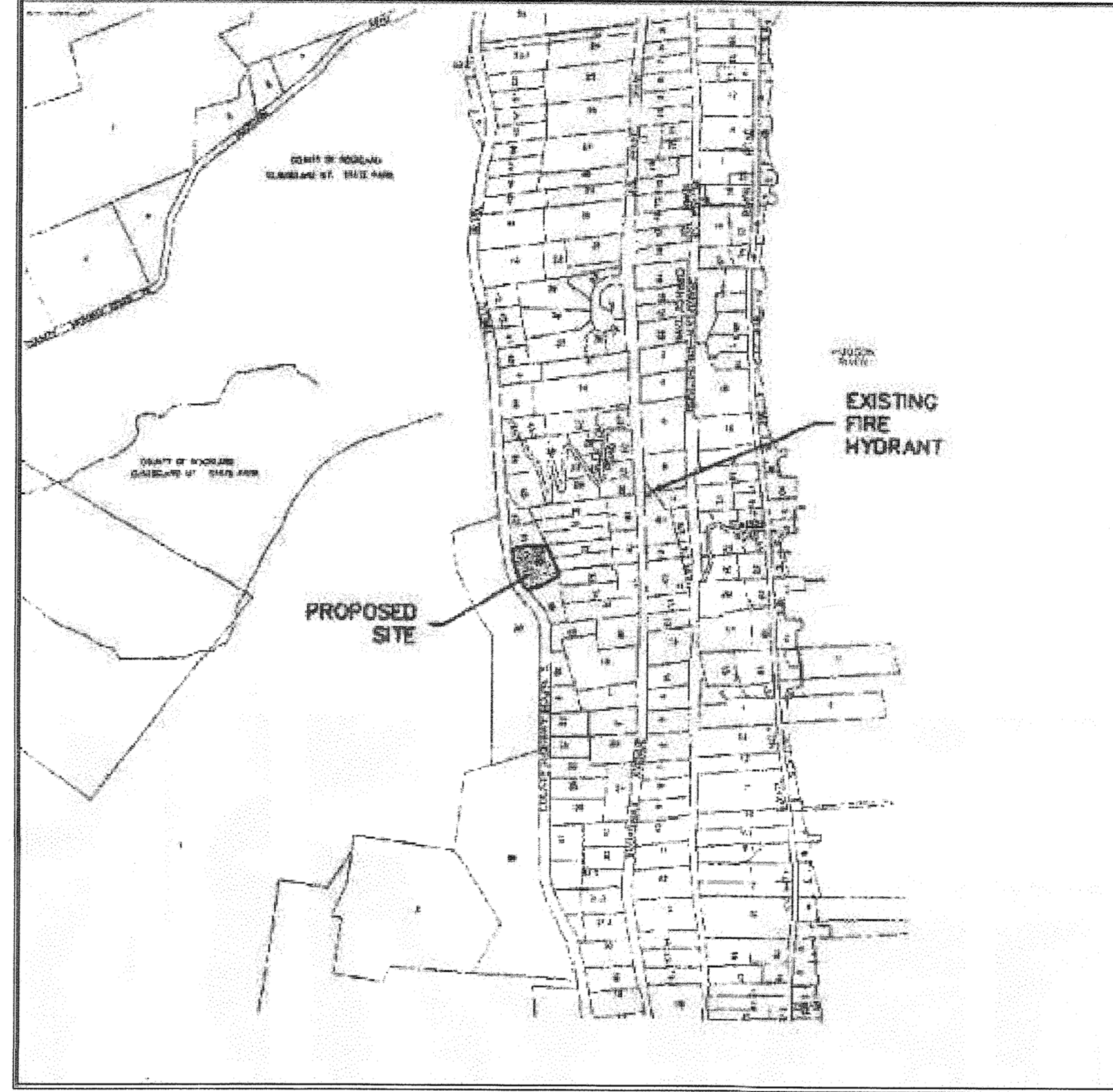

VICINITY MAP

SPECIAL INSPECTIONS	
STRUCTURAL STEEL - WELDING	BC 1704.3.1
STRUCTURAL STEEL - DETAILS	BC 1704.3.2
STRUCTURAL STEEL - HIGH STRENGTH BOLTS	BC 1704.3.3
STRUCTURAL COLD-FORMED STEEL	BC 1704.3.4
• CONCRETE - CAST-IN-PLACE	BC 1704.4
CONCRETE - PRECAST	BC 1704.4
CONCRETE - PRESTRESSED	BC 1704.4
MASONRY	BC 1704.5
WOOD - INSTALLATION OF HIGH-LOAD DIAPHRAGMS	BC 1704.6.1
WOOD-INSTALLATION OF METAL-PLATE-CONNECTED TRUSSES	BC 1704.6.2
WOOD - INSTALLATION OF PREFABRICATED I-JOISTS	BC 1704.6.3
• SUBGRADE INSPECTION	BC 1704.7.1
• SUBRAGE CONDITIONS - FILL PLACEMENT & IN-PLACE DENSITY	BC 1704.7.2
BC 1704.7.3	
SUBSURFACE INVESTIGATIONS (BORINGS/TEST PITS) TR4	BC 1704.7.4
DEEP FOUNDATION ELEMENTS TR5	BC 1704.8
HELICAL PILES (BB# 2014-020) TR5H	BC 1704.8.5
VERTICAL MASONRY FOUNDATION ELEMENTS	BC 1704.9
WALL PANELS, CURTAIN WALLS, AND VENEERS	BC 1704.10
STRUCTURAL STABILITY - EXISTING BUILDINGS	BC 1704.20.1
EXCAVATIONS-SHEETING, SHORING, AND BRACING	BC 1704.20.2
UNDERPINNING	BC 1704.20.3
BC1814	
RAISING AND MOVING OF A BUILDING	BC 1704.20.5
• POST-INSTALLED ANCHORS (BB# 2014-018, 2014-019)	BC 1704.32
SEISMIC ISOLATION SYSTEMS	BC 1707.8
CONCRETE DESIGN MIX TR3	BC1905.3
BC 1913.5	
CONCRETE SAMPLING AND TESTING TR2	BC 1905.6
BC1913.10	
PROGRESS INSPECTIONS	
FOOTING AND FOUNDATION	BC 110.3.1
STRUCTURAL WOOD FRAME	BC 110.3.2
FINAL	BC 110.5

REQUIRED SHOP DRAWING SUBMITTALS	
• REINFORCING STEEL	
STEEL DECKING AND STUD LAYOUT	
STRUCTURAL STEEL	
STEEL STAIRS	
CONCRETE STAIRS	
STRUCTURAL COLD FORM STEEL	
PRECAST CONCRETE	
• CONCRETE DESIGN MIX	
ANCHOR ROD LAYOUT	
COMPOSITE DRAWINGS OF ALL SLAB PENETRATIONS	
CONCRETE MASONRY	
CURTAIN WALLS	

59 TWEED BLVD.

No.	REMARKS	DATE
1	REVISION 1	02/02/2022
2		
3		

PROJECT:
RESIDENCE
 59 TWEED BOULEVARD
 ORANGEBURG, NY 10960

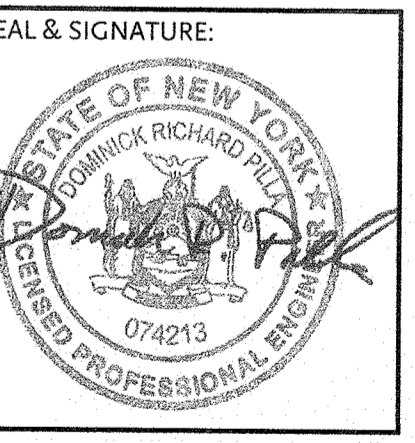

TITLE SHEET

DATE: 08/17/2021
 PROJECT No.: 21-077
 DRAWING BY: AM/JB
 CHK BY: GF

DWG No.:
S-001.00

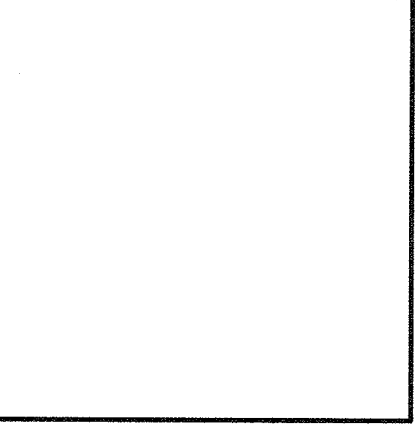
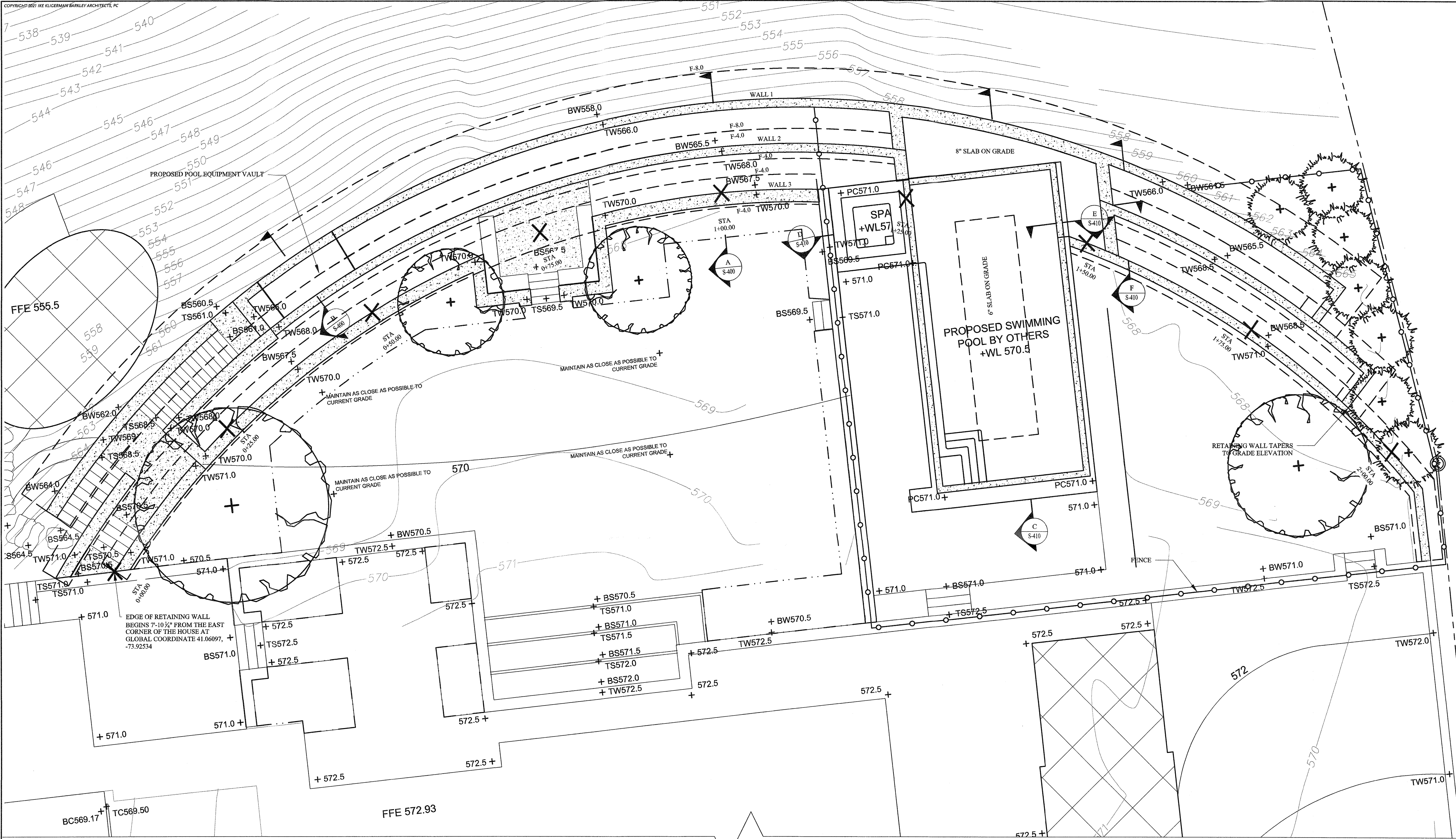

59 TWEED BLVD.

No.	REMARKS	DATE
1	REVISION 1	02/02/2022
2		
3		

PROJECT:
RESIDENCE
59 TWEED BOULEVARD
ORANBURG, NY 10960

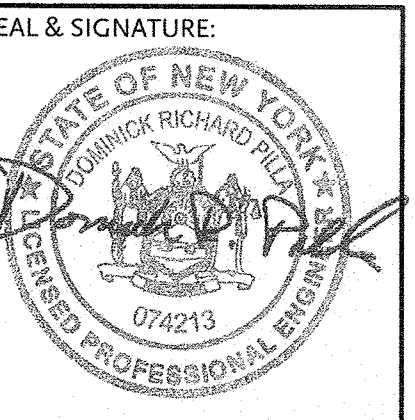

1 RETAINING WALL PLAN
1"=75'

RETAINING WALL PLAN

DATE: 08/17/2021
PROJECT No.: 21-077
DRAWING BY: AM/UB
CHK BY: GF

DWG No.: S-300.00

59 TWEED BLVD.

No.	REMARKS	DATE
1	REVISION 1	02/02/2022
2		
3		

PROJECT:
RESIDENCE
 59 TWEED BOULEVARD
 ORANGEBURG, NY 10960



RETAINING WALL SECTIONS

DATE: 08/17/2021
 PROJECT No.: 21-077
 DRAWING BY: AM/JB
 CHK BY: GF
 DWG No.:

S-400.00

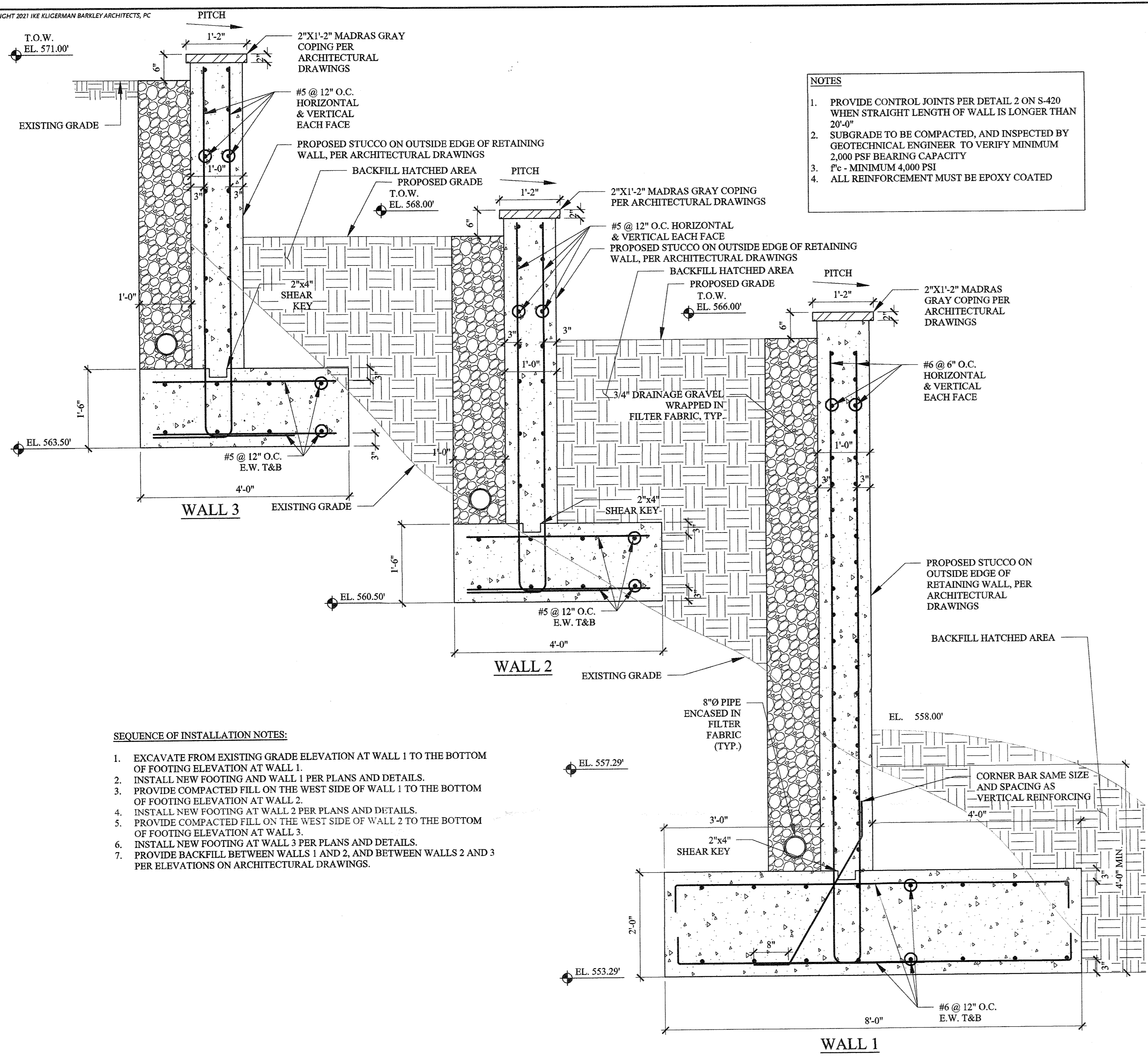

A RETAINING WALL SECTION AT STA 1+00.00
 S-300 SCALE: 3/4"=1'-0"

		FROM STA 0+00.00 TO STA 0+16.75	FROM STA 0+16.75 TO STA 0+25.00	FROM STA 0+25.00 TO STA 0+30.00	FROM STA 0+30.00 TO STA 0+75.00	FROM STA 0+75.00 TO STA 1+00.00	FROM STA 1+00.00 TO STA 1+25.00	FROM STA 1+25.00 TO STA 1+50.00	FROM STA 1+50.00 TO STA 1+75.00	FROM STA 1+75.00 TO STA 2+00.00
WALL 1	T.O.W. ELEVATION (FT)	569.0	569.0	566.0	566.0	566.0	566.0	566.0	566.0	566.0
	B.O.W. ELEVATION (FT)	564.0	562.0	560.5	558.0	558.0	558.0	558.0	561.5	561.5
	B.O.F. ELEVATION (FT)	560.0	558.0	556.5	554.0	554.0	554.0	554.0	557.5	557.5
WALL 2	T.O.W. ELEVATION (FT)	571.0	570.0	568.0	568.0	568.0	568.0	NO WALL	568.5	568.5
	B.O.W. ELEVATION (FT)	564.5	564.5	561.0	565.5	565.5	565.5	NO WALL	656.5	656.5
	B.O.F. ELEVATION (FT)	561.0	561.0	557.5	562.0	562.0	562.0	NO WALL	653.0	653.0
WALL 3	T.O.W. ELEVATION (FT)	571.0	571.0	570.0	570.0	570.0	570.0	NO WALL	571.0	571.0
	B.O.W. ELEVATION (FT)	570.5	570.5	567.5	567.5	567.5	567.5	NO WALL	568.5	568.5
	B.O.F. ELEVATION (FT)	567.0	567.0	564.0	564.0	564.0	564.0	NO WALL	565.0	565.0

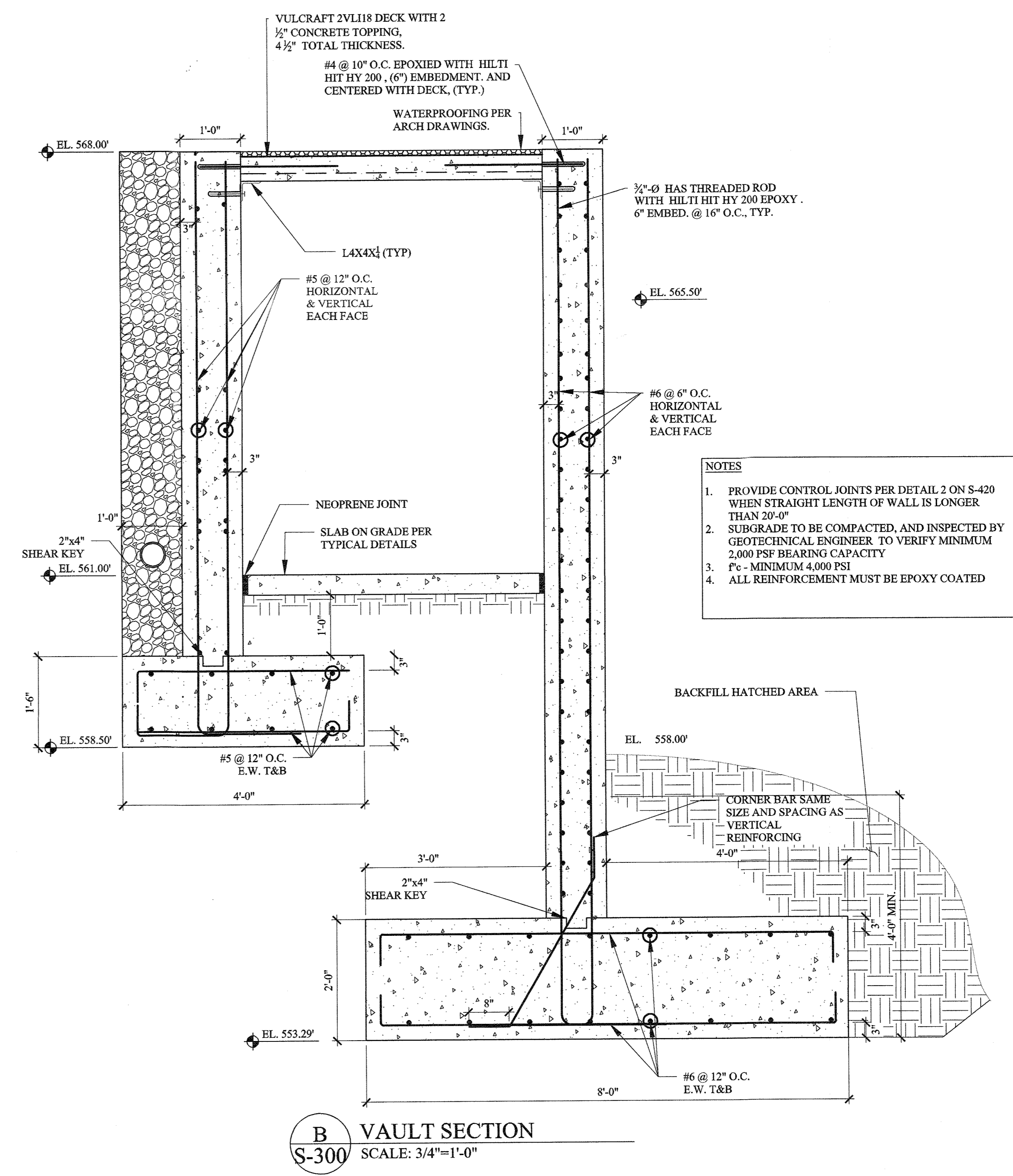

B VAULT SECTION
 S-300 SCALE: 3/4"=1'-0"

59 TWEED BLVD.

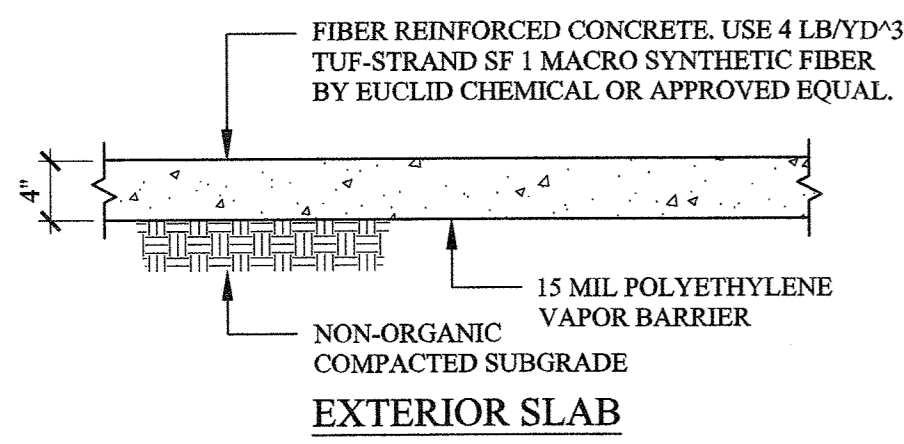

NOTES:
 - PROVIDE CONTROL JOINTS PER DETAIL 2 AT 16'-0" O.C. MAX. COORDINATE JOINT LOCATIONS WITH ARCHITECT.
 - SEE ARCHITECTURAL DRAWINGS FOR SLOPING REQUIREMENTS AT EXTERIOR SLABS

1 TYPICAL SLAB ON GRADE DETAIL
 SCALE: 3/4" = 1'-0"

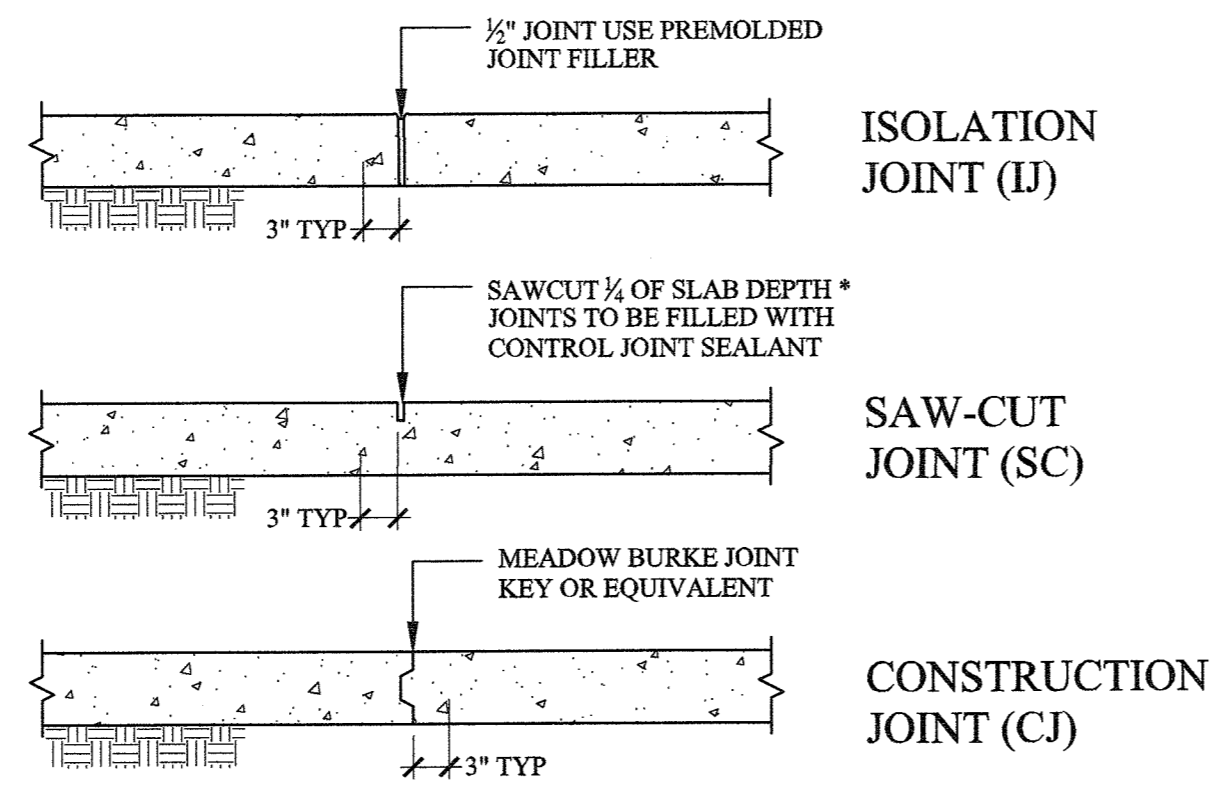

NOTES:
 * PROVIDE SEALANT WHERE REQUIRED BY ARCHITECT. SAWCUT AS SOON AS POSSIBLE AFTER CONCRETE HARDENS. SAW CUTTING MUST BE COMPLETE WITHIN 8 HRS AFTER CASTING.

2 SLAB ON GRADE CONTROL JOINTS
 SCALE: 3/4" = 1'-0"

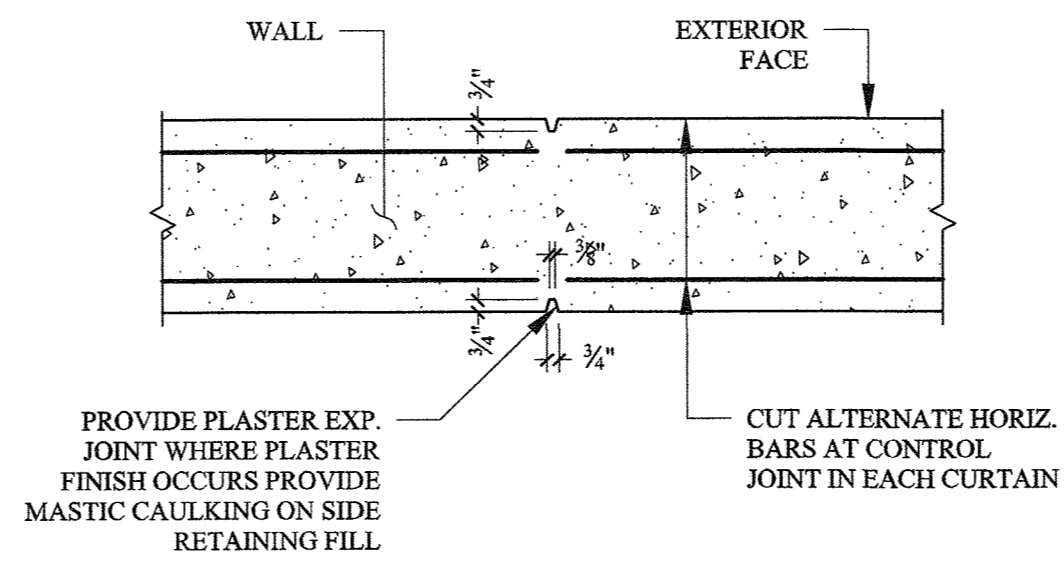

NOTE:
 CONTROL JOINT TO BE SPACED LESS THAN 20'-0" O.C. JOINT TO BE CONTINUOUS OVER TOP OF WALL. LOCATION TO BE COORDINATED WITH ARCHITECT

3 CONTROL JOINT
 SCALE: 3/4" = 1'-0"

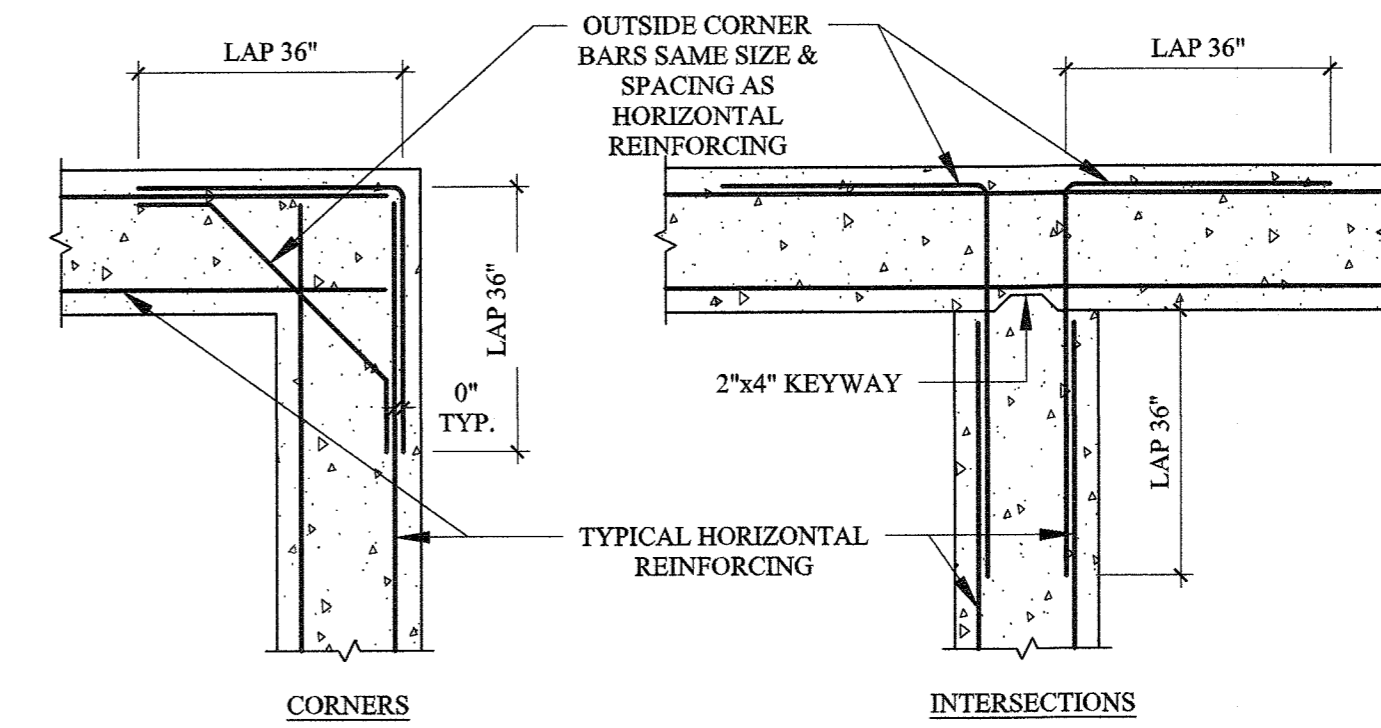

4 TYP. HORIZONTAL REINFORCING
 CONCRETE TIE BEAMS, WALLS, AND FOOTINGS
 SCALE: 3/4" = 1'-0"

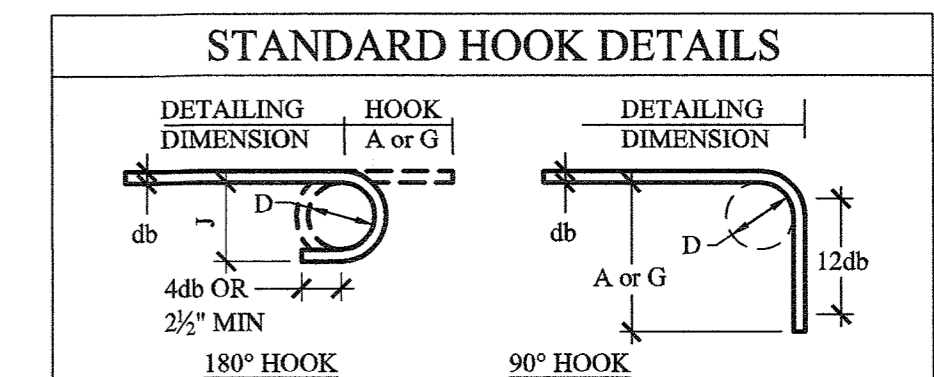

BAR SIZE	D	180° HOOKS		90° HOOKS	
		A or G	J	A or G	A or G
#3	2 1/4"	5"	3"	6"	
#4	3"	6"	4"	8"	
#5	3 3/4"	7"	5"	10"	
#6	4 1/2"	8"	6"	1'-0"	
#7	5 1/2"	10"	7"	1'-2"	
#8	6"	11"	8"	1'-4"	
#9	9 1/2"	1'-3"	11 1/2"	1'-7"	
#10	10 1/2"	1'-5"	1'-1 1/2"	1'-10"	
#11	12"	1'-7"	1'-2 1/2"	2'-0"	

MIN. LAP SPLICE LENGTH SCHEDULE					
f _c =4,000 psi			f _y =60,000 psi		
CLEAR SPACING OF BARS BEING DEVELOPED OR SPLICED NOT LESS THAN DB. CLEAR COVER NOT LESS THAN db, AND BEAM STIRRUPS OR COLUMN TIES THROUGHOUT LD NOT LESS THAN CODE MINIMUM					
OR					
CLEAR SPACING OF BARS BEING DEVELOPED OR SPLICED NOT LESS THAN 2DB AND CLEAR COVER NOT LESS THAN db					
Bar size	dc	ld	ld (top bar)	1.3*ld	1.3*ld(top)
#4	0.500	19	25	25	32
#5	0.625	24	31	31	40
#6	0.750	28	37	37	48
#7	0.875	42	54	54	70
#8	1.000	47	62	62	80
#9	1.128	54	70	70	90
#10	1.270	60	78	78	102
#11	1.410	67	87	87	113
Other cases					
Bar size	dc	ld	ld (top bar)	1.3*ld	1.3*ld(top)
#4	0.500	28	37	37	48
#5	0.625	36	46	46	60
#6	0.750	43	55	55	72
#7	0.875	62	81	81	105
#8	1.000	71	92	92	120
#9	1.128	80	104	104	136
#10	1.270	90	117	117	153
#11	1.410	100	130	130	170

No.	REMARKS	DATE
1	REVISION 1	02/02/2022
2		
3		

PROJECT:
RESIDENCE
 59 TWEED BOULEVARD
 ORANGEBURG, NY 10960

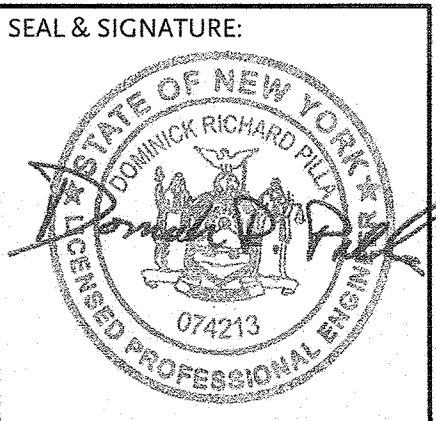

RETAINING WALL DETAILS

DATE: 08/17/2021
 PROJECT No.: 21-077
 DRAWING BY: AM/JB
 CHK BY: GF
 DWG No.:
S-420.00

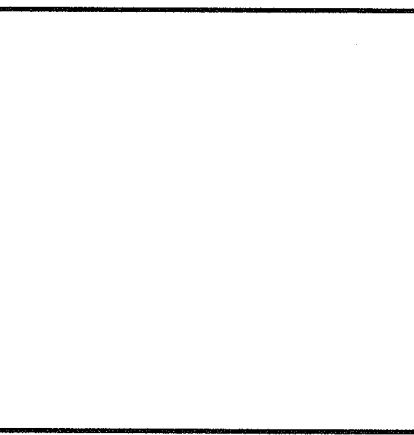

59 TWEED BLVD.

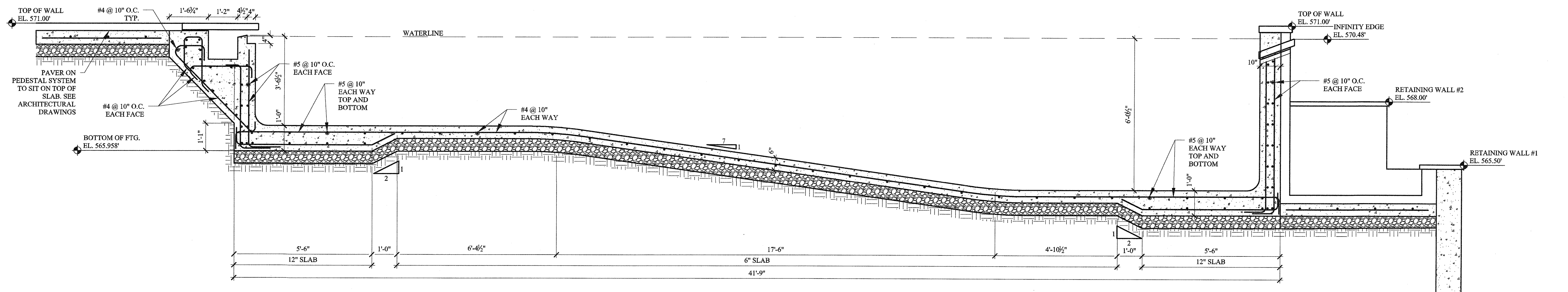

C SECTION C
 S-300 SCALE: 1/2" = 1'-0"

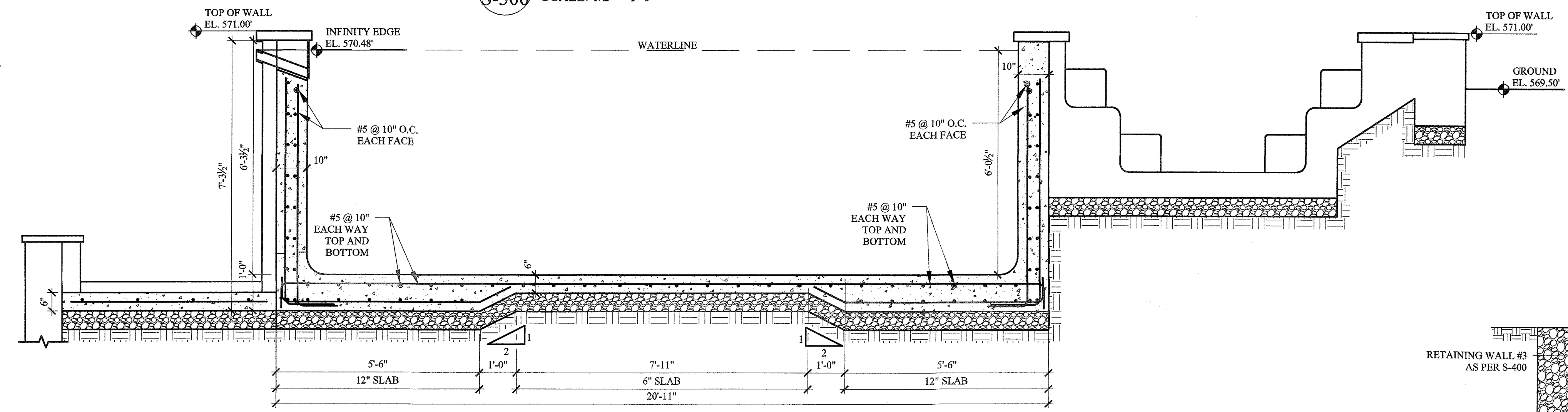

D SECTION D
 S-300 SCALE: 1/2" = 1'-0"

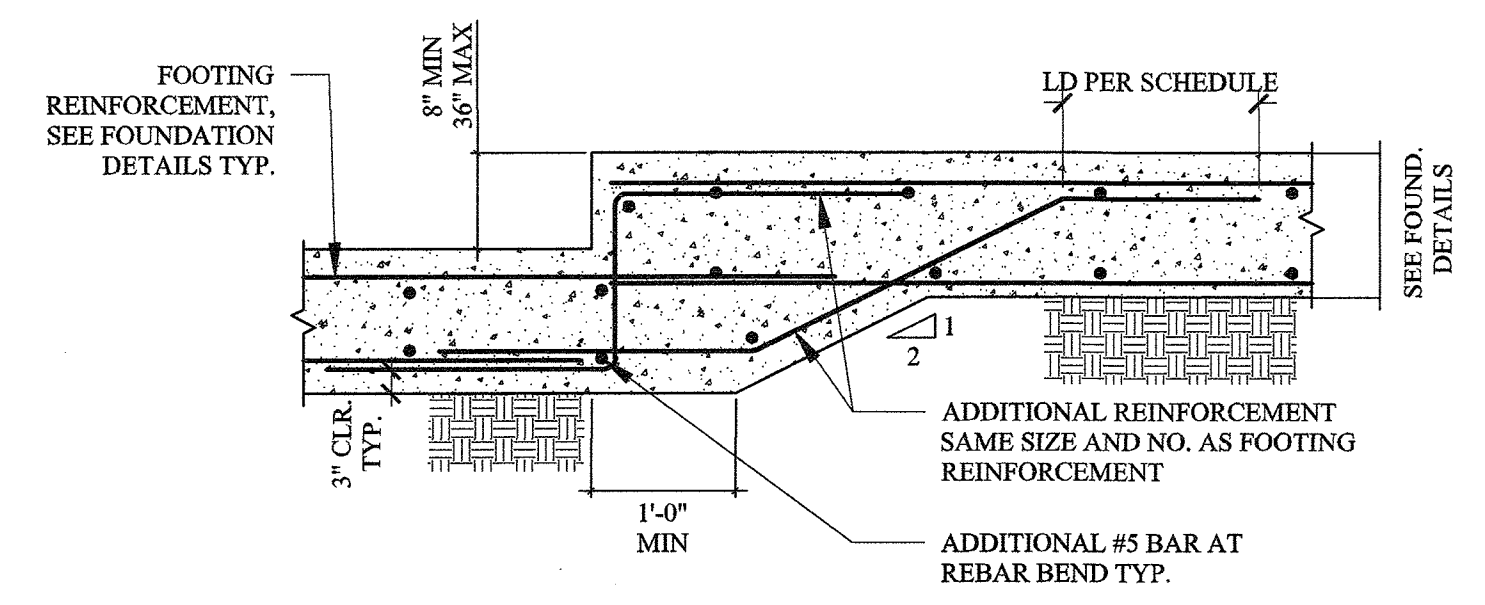

6 DETAIL
 S-300 TYPICAL STEP FOOTING DETAIL
 SCALE: 3/4" = 1'-0"

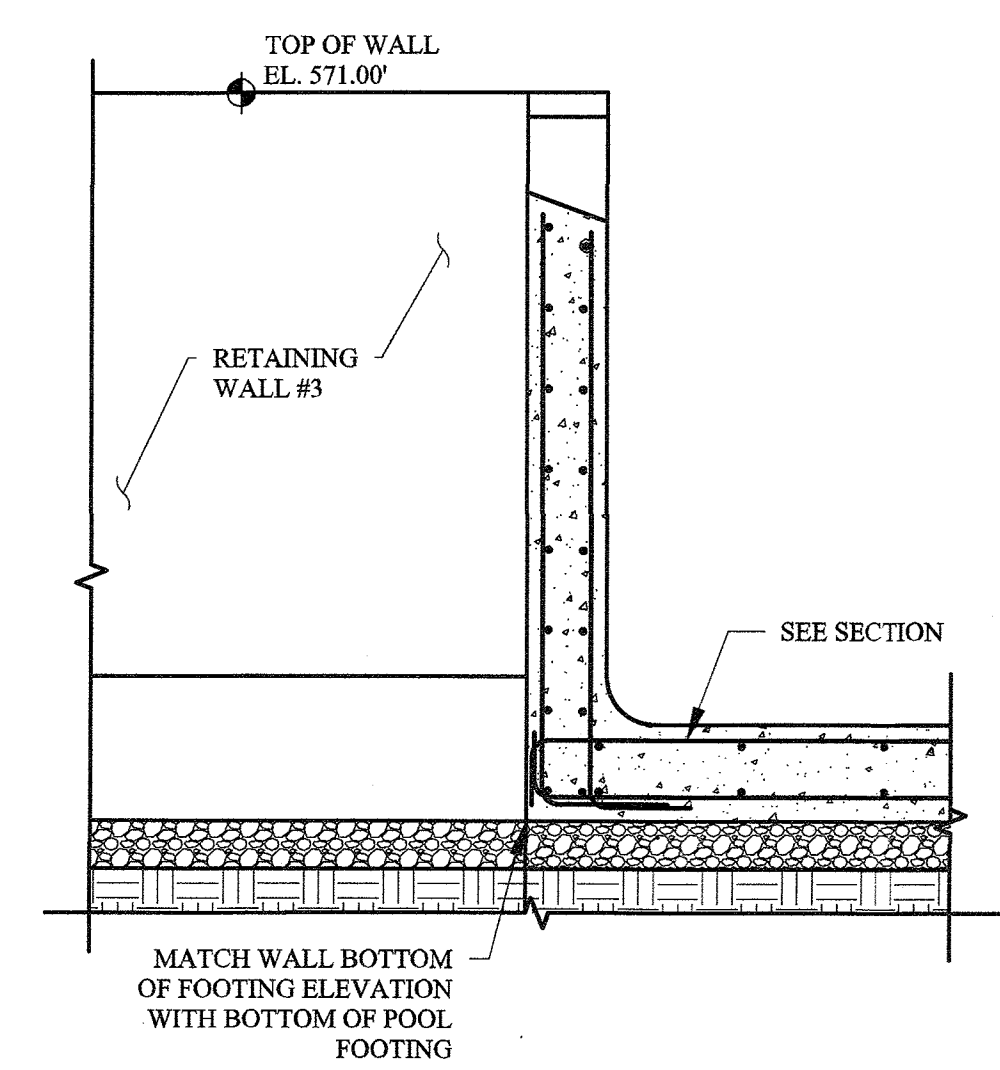

E SECTION E
 S-300 SCALE: 1/2" = 1'-0"

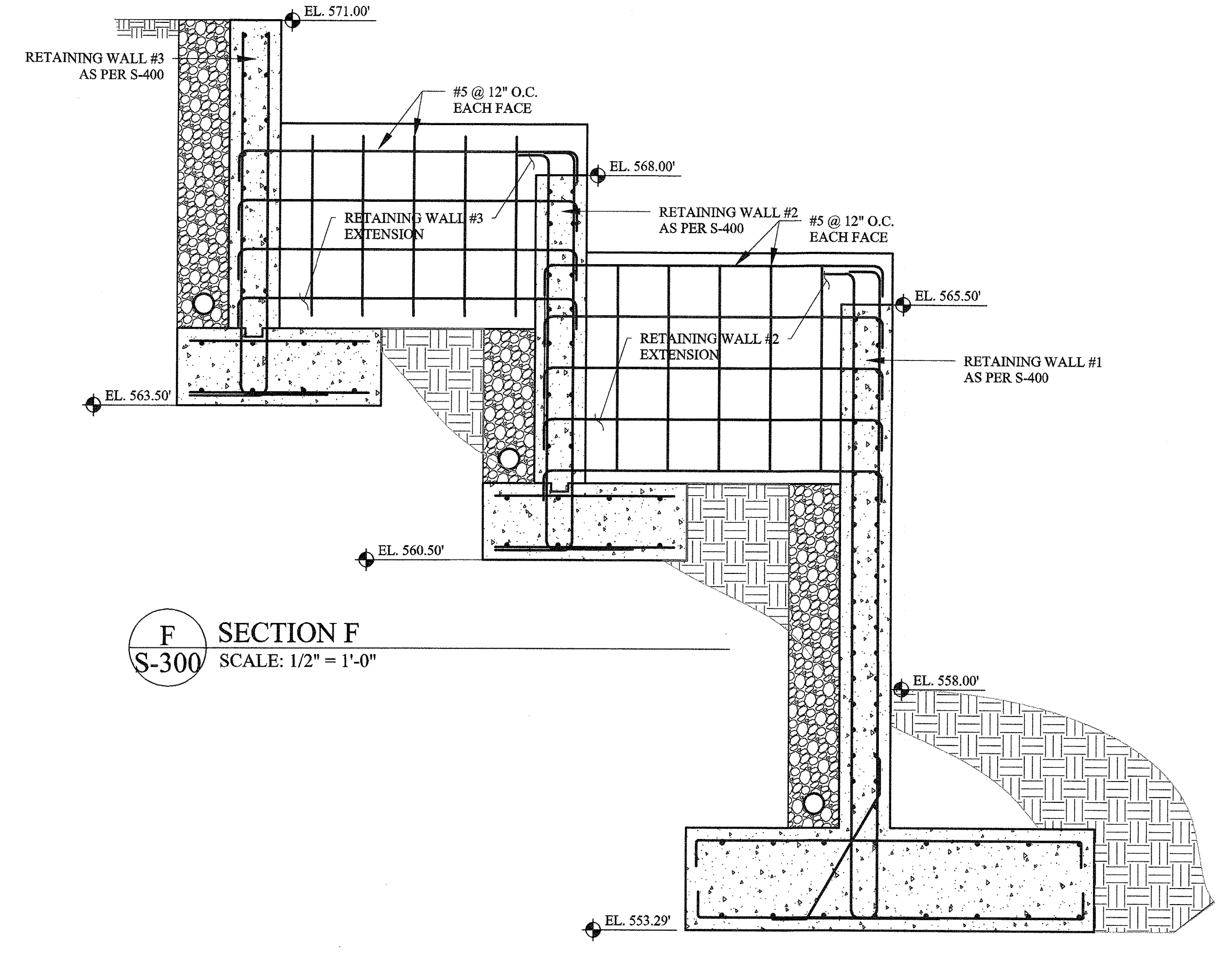

F SECTION F
 S-300 SCALE: 1/2" = 1'-0"

No.	REMARKS	DATE
1	REVISION 1	02/02/2022
2		
3		

PROJECT:
RESIDENCE
 59 TWEED BOULEVARD
 ORANBURG, NY 10960

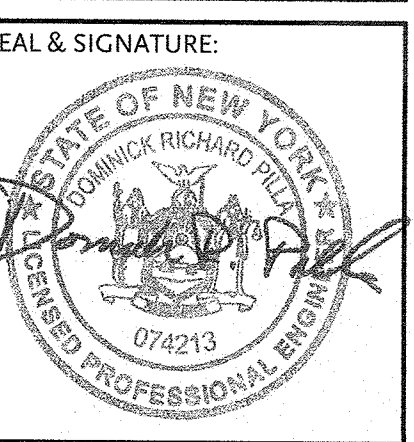

Pool Sections

DATE: 08/17/2021
 PROJECT No.: 21-077
 DRAWING BY: JB
 CHK BY: GF

DWG No.: **S-410.00**