

# PROJECT NAME: 59 TWEED BOULEVARD

PROJECT ARCHITECT: IKE KLIGERMAN BARKLEY  
 CIVIL ENGINEER: DOMINICK R.PILLA ASSOCIATES PC

PROJECT ADDRESS: 59 TWEED BOULEVARD, NYACK, NY 10965

ISSUED: FOR BUILDING PERMIT

## CIVIL PLANS

DATE: 02/02/2022

| INDEX OF DRAWINGS |       |            |   |
|-------------------|-------|------------|---|
| PAGE #            | DWG # | REVISION # | DRAWING TITLE                             |
| 1                 | C-001 | 01         | TITLE SHEET                               |
| 2                 | C-002 | 00         | GENERAL NOTES                             |
| 3                 | C-003 | 00         | EXISTING SURVEY AT 59 TWEED BLVD          |
| 4                 | C-100 | 01         | PROPOSED SITE AND DRAINAGE PLAN           |
| 5                 | C-101 | 00         | EXISTING SUBCATCHMENT AREAS               |
| 6                 | C-102 | 00         | PROPOSED SUBCATCHMENT AREAS               |
| 7                 | C-110 | 00         | PROPOSED DETENTION SYSTEMS                |
| 8                 | C-200 | 00         | SITE DEMOLITION PLAN                      |
| 9                 | C-210 | 01         | SOIL EROSION AND SEDIMENT CONTROL PLAN    |
| 10                | C-300 | 01         | STORMWATER MANAGEMENT DETAILS (1)         |
| 11                | C-310 | 00         | STORMWATER MANAGEMENT DETAILS (2)         |
| 12                | C-320 | 00         | STORMWATER PROFILES                       |
| 13                | C-400 | 00         | SOIL EROSION AND SEDIMENT CONTROL DETAILS |

**PROPERTY INFORMATION:**

ADDRESS: 59 TWEED BOULEVARD, NYACK, NY 10965  
 SECTION: 71.13  
 BLOCK: 1  
 LOT: 40  
 LOT AREA: 47,906 SQFT

ZONING DISTRICT: R-22  
 SCHOOL DISTRICT: SOUTH ORANGETOWN CENTRAL DISTRICT 1  
 FIRE DISTRICT: BLAUVELT  
 WATER DISTRICT: BLAUVELT  
 SEWER DISTRICT: ORANGETOWN SEWER DISTRICT  
 LIGHTING DISTRICT: ORANGETOWN

| LEGEND                             |                                       |
|------------------------------------|---------------------------------------|
| SECTION #<br>XX<br>SHT #           | SECTION SYMBOL                        |
| DETAIL #<br>XX<br>SHT #            | DETAIL REFERENCE SYMBOL               |
| SECTION OR DETAIL #<br>XX<br>SHT # | PLAN, SECTION, OR DETAIL TITLE SYMBOL |
| XXX                                | ELEVATION SYMBOL                      |

**ABBREVIATION**

|          |  |
|----------|--|
| AESS     | ARCHITECTURALLY EXPOSED STRUCTURAL STEEL       |
| B        | BOTTOM REINFORCEMENT                           |
| BOC      | BOTTOM OF CURB                                 |
| BM       | BEAM   |
| BS       | BOTH SIDES                                     |
| BU       | BUILT UP MEMBER                                |
| C        | COMPRESSION FORCE IN KIPS                      |
| CANT.    | CANTILEVER                                     |
| CL       | CENTER LINE                                    |
| CG       | CENTER OF GRAVITY                              |
| COL      | COLUMN   |
| CONT     | CONTINUOUS                                     |
| COMP LAP | COMPRESSION REINF LAP SLICE                    |
| CP       | COMPLY PENETRATION ERF                         |
| DB       | FISMRYRT OF REINFORCEMENT BAR                  |
| DEL      | DELTA OR CHANGE IN ELEVATION                   |
| (E)      | EXISTING CONSTRUCTION                          |
| EF       | EACH FACE                                      |
| EL       | ELEVATION                                      |
| EW       | EACH WAY                                       |
| F        | FINISHED SURFACE                               |
| GB       | GRADE BEAM                                     |
| H        | HORIZONTAL REINFORCEMENT                       |
| H        | HORIZONTAL FORCE IN KIPS                       |
| JLJ2     | NEW CODE FORMED STEEL JOISTS                   |
| LAP      | FULL TENSION CAPACITY LAP SPLICE               |
| LD       | TENSION DEVELOPMENT LENGTH FOR REINFORCINGBARS |
| LDC      | COMPRESSION SPLICE LENGTH FOR REINFORCE BARS   |
| LLBB     | LONG LEGS BACK-TO-BACK                         |
| LW       | LIGHTWEIGHT CONCRETE                           |
| M        | BENDING MOMENT IN FOOT-KIPS                    |
| MC       | MOMENT CONNECTION SHOWN ON DRAWING             |
| MIN      | MINIMUM  |
| (N)      | NEW CONSTRUCTION                               |
| N        | BEARING BOLTS THREADS INCLUDED IN SHEAR PLANE  |
| NTS      | NOT TO SCALE                                   |
| OC       | ON CENTER                                      |
| PC       | PILE CAP                                       |
| PL       | PLATE  |
| PP       | PARTIAL PENETRATION WELD                       |
| PEOP     | PROPERTY LINE                                  |
| SAD      | SEE ARCHITECTURAL DRAWINGS/DETAILS             |
| S1,S2    | SLAB ON DECK TYPE                              |
| SC       | SLIP CRITICAL BOLT                             |
| SIM      | SIMILAR  |
| T        | TENSION FORCE IN KIPS                          |
| T        | THICKNESS                                      |
| T        | TOP REINFORCEMENT                              |
| TBC      | TO BE CONFIRMED                                |
| TOC      | TOP OF CURB                                    |
| TOF      | TOP OF FOOTING                                 |
| TOS      | TOP OF STEEL                                   |
| TYP      | TYPICAL  |
| UNO,UON  | UNLESS OTHERWISE NOTED                         |
| M        | VERTICAL REINFORCEMENT                         |
| V        | VERTICAL BEAM END REACTION IN KIPS             |
| VIF      | VERIFY IN FIELD                                |
| WP       | WORKPOINT                                      |
| WWF      | WELDED WIRE FABRIC                             |

**CONSTRUCTION NOTES:**

- ANY EXISTING UTILITIES AND UNDERGROUND STRUCTURES SHOWN ON THE PLAN ARE BASED UPON THE BEST AVAILABLE PUBLIC RECORDS, PRIVATE RECORDS AS SUPPLIED BY THE OWNER, OR DATA OBTAINED VERBALLY FROM OWNERS OR OFFICIALS FAMILIAR WITH THE PROJECT SITE. NEITHER THE OWNER NOR THE ENGINEER GUARANTEE ACCURACY OR COMPLETENESS OF THIS INFORMATION AND ASSUME NO RESPONSIBILITY FOR IMPROPER LOCATIONS ON THE CONSTRUCTION PLANS. OTHER UNDERGROUND FACILITIES NOT SHOWN ON THE DRAWINGS MAY BE ENCOUNTERED DURING THE COURSE OF THE WORK. ALL INVERT ELEVATIONS SHOWN ON THE DRAWINGS SHALL BE VERIFIED BY THE CONTRACTOR PRIOR TO CONSTRUCTION.
- IF CHANGED CONDITIONS ARE ENCOUNTERED, THE CONTRACTOR SHALL NOTIFY THE ENGINEER IMMEDIATELY OF EITHER (1) PREEXISTING SUBSURFACE CONDITIONS DIFFERING FROM THOSE INDICATED IN THE PLANS, OR (2) PREEXISTING UNKNOWN SUBSURFACE CONDITIONS OF AN UNUSUAL NATURE, DIFFERING MATERIALLY FROM THOSE ORIGINALLY ENCOUNTERED AND GENERALLY RECOGNIZED AS INHERENT IN THE CHARACTER OF THE WORK PROVIDED FOR IN THE CONTRACT. THE CONTRACTOR AND/OR OWNER SHALL MAKE NO CLAIMS TO THE ENGINEER FOR RECOMPENSATION FOR EXTRA WORK RESULTING FROM CHANGED CONDITIONS UNLESS THE ENGINEER HAS APPROVED THE WORK IN WRITING.
- CONTRACTOR SHALL PROVIDE ALL NECESSARY PERMITS AND APPROVED CITY ORDINANCES AND SHALL POST SUCH DOCUMENTS AT VISIBLE LOCATIONS AND MAINTAIN UPDATED DOCUMENTATION ACCORDINGLY.
- CONTRACTOR SHALL CALL THE UTILITIES UNDERGROUND LOCATION CENTER FOR FIELD LOCATIONS OF ALL UTILITIES AND SHALL NOT BEGIN EXCAVATION UNTIL ALL KNOWN UNDERGROUND FACILITIES IN THE VICINITY OF THE PROPOSED WORK HAVE BEEN LOCATED AND MARKED. IF THE UTILITY IS NOT A SUBSCRIBER OF THE UTILITIES UNDERGROUND LOCATION CENTER, THEN THE CONTRACTOR SHALL GIVE NOTICE TO THAT UTILITY.
- THE CONTRACTOR IS RESPONSIBLE FOR REVIEW OF ALL INFORMATION PROVIDED BY UTILITY PURVEYORS, AND CITY OR STATE RECORDS RELATED TO THE EXISTING UNDERGROUND UTILITIES. THE CONTRACTOR IS RESPONSIBLE FOR AVOIDING DAMAGE TO THESE FACILITIES AND SHALL RESTORE ALL UTILITIES AT CONTRACTOR'S EXPENSE.
- CONTRACTOR SHALL NOTIFY ALL UTILITY SERVICES FOR TEMPORARY SHUT OFF AS REQUIRED. CONTRACTOR SHALL MAINTAIN AND PROTECT SERVICES AGAINST DAMAGE DURING DEMOLITION OPERATIONS.
- NO PUBLIC WAYS OR WALKS MAY BE OBSTRUCTED WITHOUT THE WRITTEN PERMISSION OF GOVERNING AUTHORITIES AND OF THE OWNER. WHERE ROUTES ARE PERMITTED TO BE CLOSED, PROVIDE ALTERNATE ROUTES AND SIGNAGE IF REQUIRED.
- WET DEBRIS WITH WATER AS NECESSARY TO LIMIT DUST TO LOWEST PRACTICAL LEVEL. DO NOT WET TO THE EXTENT OF FLOODING, CONTAMINATED RUNOFF, OR ICING.
- ANY PORTIONS OF PAVEMENT TO BE REMOVED MUST BE SEPARATED BY MAKING A NEAT VERTICAL SAW CUT ALONG THE BOUNDARIES OF THE AREA TO BE REMOVED. MAKE CUTS AT CLOSEST PAVING JOINT.
- THE GENERAL CONTRACTOR SHALL BE RESPONSIBLE FOR PROVIDING ALL LABOR, EQUIPMENT, AND SERVICES TO PROPERLY EXECUTE THE DEMOLITION AND REMOVAL WORK INDICATED ON THESE CONSTRUCTION DOCUMENTS.
- ALL DEMOLITION WORK SHALL BE PERFORMED WITH MINIMUM DAMAGE TO THE EXISTING WORK TO REMAIN. IT SHALL BE RECOGNIZED THAT THE UTMOST CARE BE TAKEN WHEN PERFORMING THE DEMOLITION WORK. PROVIDE BARRICADES, BARRIERS, AND SHORING WHERE REQUIRED TO PROTECT THE PUBLIC, PERSONNEL, CONSTRUCTION, AND VEGETATION TO REMAIN. COMPLY WITH ALL STATE AND LOCAL AGENCY REQUIREMENTS.
- PROVISIONS SHALL BE MADE TO ALLEVIATE THE SPREAD OF DEBRIS, DIRT, AND DUST TO THE ADJACENT PROPERTIES. THE PROPERTY SHALL BE KEPT AS CLEAN AS POSSIBLE AT ALL TIMES. MAINTAIN HAULING ROUTES CLEAN AND FREE OF ANY DEBRIS RESULTING FROM DEMOLITION WORK ON THIS PROJECT. ANY HAZARDOUS MATERIAL REMOVAL, SUCH AS ASBESTOS REMOVAL, SHALL BE PERFORMED PRIOR TO ANY DEMOLITION ACTIVITY. THE HAZARDOUS MATERIAL REMOVAL SHALL BE PERFORMED BY A LICENSED ABATEMENT COMPANY.
- THE REFUSE RESULTING FROM ANY CLEARING AND GRUBBING AND ALL DEBRIS AND MATERIALS FROM ANY STRUCTURE(S) TO BE DEMOLISHED SHALL BE DISPOSED OF BY THE CONTRACTOR IN A MANNER CONSISTENT WITH ALL GOVERNMENT REGULATIONS. IN NO CASE SHALL REFUSE MATERIAL BE LEFT ON THE PROJECT SITE, PUSHED ONTO ADJUTING PRIVATE PROPERTIES, OR BE BURIED IN EMBANKMENTS OR TRENCHES ON THE PROJECT SITE. DEBRIS SHALL NOT BE DEPOSITED IN ANY STREAM, LAKE, WETLAND, BODY OF WATER, OR IN ANY STREET OR ALLEY, OR UPON ANY PRIVATE PROPERTY EXCEPT BY WRITTEN CONSENT OF THE PRIVATE PROPERTY OWNER. NO RECLAIMED LUMBER OR MATERIALS SHALL BE RE-USED EXCEPT AS SPECIFICALLY APPROVED BY THE ARCHITECT OR OWNER.
- WHERE DEMOLITION AND CUTTING WORK HAS OCCURRED OR WHERE EXISTING SURFACES, MATERIALS, OR OTHER ITEMS HAVE BEEN DAMAGED OR DISTURBED AS A RESULT OF THE CONTRACTED WORK, THE SAID SURFACES AND AREAS SHALL BE CAREFULLY CLOSED UP, PATCHED, REPAIRED, FINISHED, OR RESTORED AS REQUIRED TO BE CONTIGUOUS TO EXISTING SURROUNDING SURFACES.
- ALL MECHANICAL, ELECTRICAL, AND PLUMBING DEMOLITION, INCLUDING GAS LINE REMOVAL IS TO BE PERFORMED BY A CONTRACTOR OR SUB-CONTRACTOR LICENSED IN THE PARTICULAR TRADE.

**STORM WATER SYSTEM CLEANING AND MAINTENANCE:**

STORM WATER SYSTEM, INCLUDING ANY ROOF GUTTERS AND UNDERGROUND PIPING, SHOULD BE CLEANED OF LEAVES, SAND, DIRT, SEDIMENT, TRASH AND OTHER DEBRIS BY HAND OR BY VACTOR TRUCK. THE SYSTEM IS TO BE EVALUATED, CLEANED AND MAINTAINED AT LEAST TWO TIMES PER YEAR. SURFACE GRATES AND INTERIOR SLUMPS SHOULD BE MAINTAINED TO FUNCTION AS ORIGINALLY DESIGNED. SEE MAINTENANCE PLAN ON FILE WITH BOTH THE PROPERTY OWNER AND THE LOCAL BUILDING DEPARTMENT FOR MORE DETAILS.

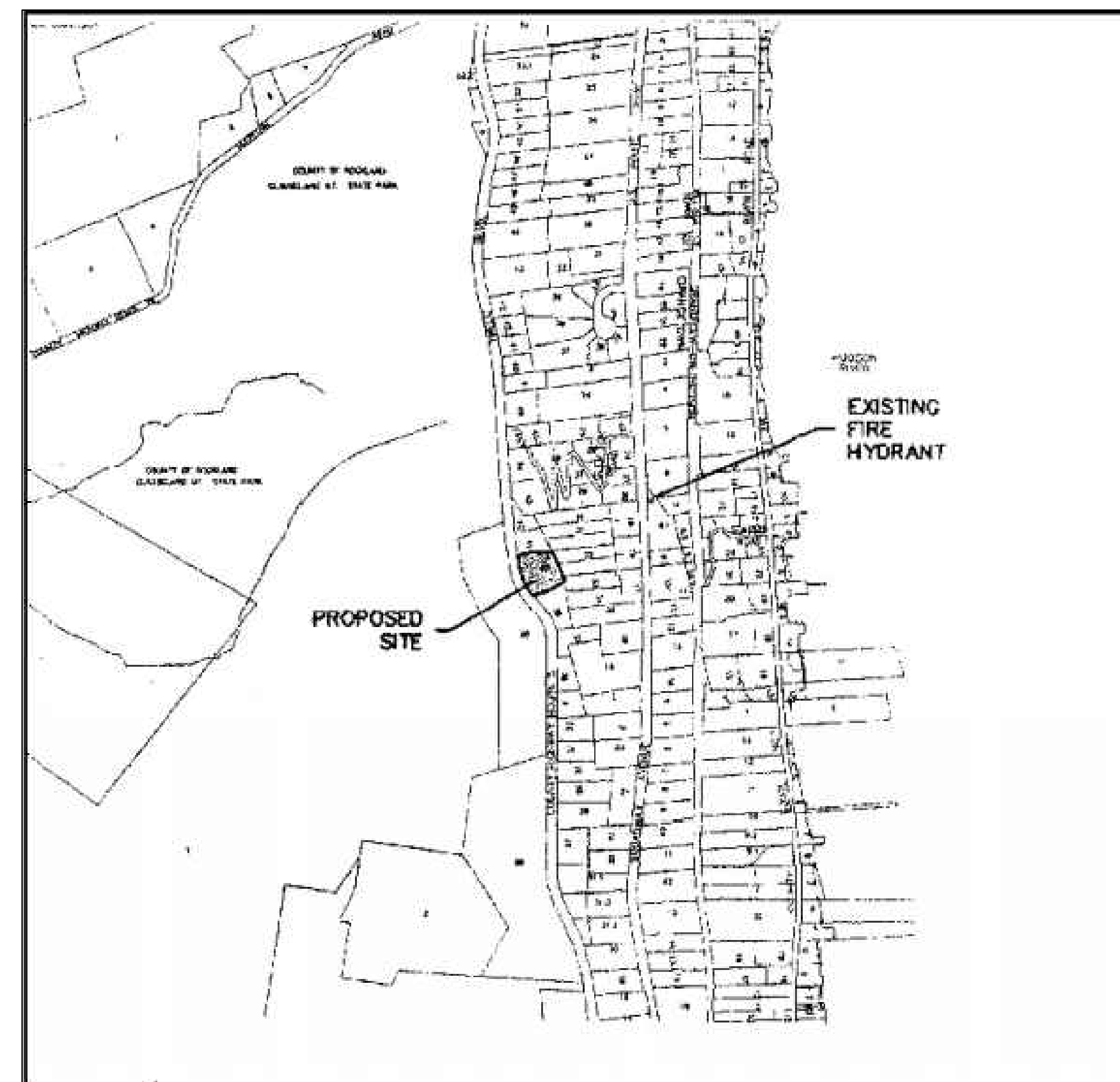

VICINITY MAP

| ZONING ANALYSIS (ZONE R-22, USE GROUP 1, SINGLE FAMILY RESIDENCE) |                    |                                     |                                    |
|---|--------------------|-------------------------------------|------------------------------------|
| USE GROUP 0   | REQUIRED           | EXISTING                            | PROPOSED                           |
| LOT GROSS AREA (SQFT)   | 22,500             | 47,906                              | 47,906                             |
| AREAS WITH SLOPES > 25% (SQFT)                                    | -                  | 15,625.80                           | 15,625.80                          |
| SLOPE DEDUCTION SLOPES > 25% (SQFT)                               | -                  | 7,812.90                            | 7,812.90                           |
| NET AREA (SQFT)   | -                  | 40,078.10                           | 40,078.10                          |
| FLOOR AREA RATIO  | 0.20               | 0.13 <sup>2</sup>                   | 0.189 <sup>2</sup>                 |
| LOT WIDTH (FT)  | 125                | 249.41                              | 249.41                             |
| STREET FRONTAGE (FT)  | 75                 | 256.14                              | 256.14                             |
| FRONT YARD SETBACK (FT)   | 40                 | 43.5                                | 40.6                               |
| SIDE YARD (ONE) SETBACK (FT)                                      | 25                 | 24.3 <sup>1</sup>                   | 24.3 <sup>1</sup>                  |
| SIDE YARD (BOTH) SETBACK (FT)                                     | 60                 | 100.7                               | 63.3                               |
| REAR YARD SETBACK (FT)  | 45                 | 98.6                                | 98.6                               |
| BLDG. HEIGHT 9"/FT FROM LOT LINE                                  | 9"/FT <sup>3</sup> | 28'-10"<br>(7.95'/FT)<br>MAIN HOUSE | 19'-2"<br>(5.67'/FT)<br>POOL HOUSE |

<sup>1</sup> EXISTING NON-CONFORMING CONDITIONS  
<sup>2</sup> BASED ON FLOOR AREA OF 6,168 SQFT EXISTING, 7,587 PROPOSED  
<sup>3</sup> ALLOWABLE BUILDING HEIGHT IS 9"/FT FROM LOT LINE (DSL).  
 EXISTING BUILDING IS 43.5' FROM DSL  
 EXISTING 9"/FT X 43.5' = 393.5" = 32.77'  
 EXISTING HEIGHT OF HOUSE 28'-10" = 346"/43.5 = 7.95 IN/FT  
 PROPOSED BUILDING IS 40.6' FROM DSL  
 PROPOSED 9"/FT X 40.6' = 365.4" = 30.45'  
 PROPOSED HEIGHT OF POOL HOUSE 19'-2" = 230"/40.6 = 5.67 IN/FT

**Ike Kligerman Barkley**

330 West Forty-Second Street  
 New York, NY 10096  
 212 268 0128

59 TWEED BLVD.

| No. | REMARKS    | DATE       |
|-----|------------|------------|
| 1   | REVISION 1 | 02/02/2022 |
| 2   |            |            |
| 3   |            |            |

PROJECT: RESIDENCE  
 59 TWEED BOULEVARD  
 ORANGETOWN, NY 10966



TITLE SHEET

DATE: 02/02/2022  
 PROJECT No.: 21-077  
 DRAWING BY: JB  
 CHK BY: GF  
 DWG No.:

C-001.01

**GENERAL NOTES**

UNLESS OTHERWISE NOTED OR SHOWN ON THE CIVIL DRAWINGS, THE FOLLOWING REQUIREMENTS, TOGETHER WITH THE PROJECT PLANS, SPECIFICATIONS AND GEOTECHNICAL REPORT APPLY TO THE STRUCTURES IN THIS CONTRACT.

1. CONSTRUCTION IS TO COMPLY WITH THE REQUIREMENTS OF THE GOVERNING BUILDING CODE AND ALL OTHER APPLICABLE FEDERAL, STATE, AND LOCAL CODES, STANDARDS, REGULATIONS AND LAWS.
2. THE CIVIL DOCUMENTS SHALL BE USED IN CONJUNCTION WITH AND COORDINATED WITH THE ARCHITECTURAL, STRUCTURAL, AND MEP CONTRACT DOCUMENTS AS WELL AS ANY OTHER TRADES. IF A CONFLICT EXISTS, CONTRACTOR SHALL NOTIFY THE ARCHITECT/ENGINEER AND OBTAIN CLARIFICATION PRIOR TO BIDDING AND PROCEEDING WITH WORK.
3. THE GENERAL CONTRACTOR SHALL COORDINATE ALL CONTRACT DOCUMENTS WITH FIELD CONDITIONS, DIMENSIONS, ELEVATIONS AND PROJECT SHOP DRAWINGS PRIOR TO CONSTRUCTION. DO NOT SCALE DRAWINGS; USE ONLY PRINTED DIMENSIONS. REPORT ANY DISCREPANCIES IN WRITING TO THE ARCHITECT/ENGINEER PRIOR TO PROCEEDING WITH WORK. DO NOT CHANGE SIZE OR LOCATION OF STRUCTURAL MEMBERS WITHOUT WRITTEN INSTRUCTIONS FROM THE STRUCTURAL ENGINEER OF RECORD.
4. CONTRACTORS WHO DISCOVER DISCREPANCIES, OMISSIONS OR VARIATIONS IN THE CONTRACT DOCUMENTS DURING BIDDING SHALL IMMEDIATELY NOTIFY THE ARCHITECT. THE ARCHITECT WILL RESOLVE THE CONDITION AND ISSUE A WRITTEN CLARIFICATION.
5. THE CONTRACTOR SHALL PROTECT ADJACENT PROPERTY, HIS OWN WORK AND THE PUBLIC FROM HARM. THE CONTRACTOR IS SOLELY RESPONSIBLE FOR CONSTRUCTION MEANS AND METHODS, AND JOBSITE SAFETY INCLUDING ALL OSHA REQUIREMENTS.
6. DETAILS LABELED "TYPICAL" APPLY TO ALL SITUATIONS THAT ARE THE SAME OR SIMILAR TO THOSE SPECIFICALLY REFERENCED, WHETHER OR NOT THEY ARE KEVED IN AT EACH LOCATION. QUESTIONS REGARDING THE APPLICABILITY OF TYPICAL DETAILS SHALL BE RESOLVED BY THE ARCHITECT.

**CODES AND SPECIFICATIONS**

THE DESIGN SHOWN ON THESE DRAWINGS IS BASED ON THE FOLLOWING CODES, SPECIFICATIONS AND STANDARDS:

1. " BUILDING CODE OF NEW YORK STATE," 2020.  
ASCE 7-16: "MINIMUM DESIGN LOADS FOR BUILDINGS AND OTHER STRUCTURES."

**SHOP DRAWINGS AND OTHER SUBMITTALS**

1. INCOMPLETE SUBMITTALS WILL BE RETURNED WITHOUT REVIEW.
2. ON FIRST SUBMITTAL, CLEARLY FLAG AND CLOUD ALL DIFFERENCES FROM THE CONTRACT DOCUMENTS. ON RE-SUBMITTALS, FLAG AND CLOUD ALL CHANGES AND ADDITIONS TO PREVIOUS SUBMITTAL. ONLY CLOUDED ITEMS WILL BE REVIEWED.
3. A DELEGATED ENGINEER IS DEFINED AS A NEW YORK STATE LICENSED ENGINEER WHO SPECIALIZES IN AND UNDERTAKES THE DESIGN OF CIVIL COMPONENTS OR CIVIL SYSTEMS INCLUDED IN A SPECIFIC SUBMITTAL PREPARED FOR THIS PROJECT AND IS AN EMPLOYEE OR OFFICER OF, OR CONSULTANT TO, THE CONTRACTOR OR FABRICATOR RESPONSIBLE FOR THE SUBMITTAL. THE DELEGATED ENGINEER SHALL SIGN, SEAL AND DATE THE SUBMITTAL, INCLUDING CALCULATIONS AND DRAWINGS. SEE SPECIFICATIONS FOR MORE SPECIFIC CRITERIA.
4. THE TRADE CONTRACTOR IS RESPONSIBLE FOR CONFIRMING AND CORRELATING DIMENSIONS AT THE JOB SITES, FOR TOLERANCES, CLEARANCES, QUANTITIES, FABRICATION PROCESSES AND TECHNIQUES OF CONSTRUCTION, COORDINATION OF THE WORK WITH OTHER TRADES AND FULL COMPLIANCE WITH THE CONTRACT DOCUMENTS.
5. THE GENERAL CONTRACTOR/CONSTRUCTION MANAGER SHALL REVIEW AND APPROVE SUBMITTALS AND SHALL SIGN AND DATE EACH DRAWING PRIOR TO SUBMITTING TO THE ARCHITECT. THIS APPROVAL IS TO CONFIRM THAT THE SUBMITTAL IS COMPLETE, COMPLIES WITH THE SUBMITTAL REQUIREMENTS AND IS COORDINATED WITH FIELD DIMENSIONS, OTHER TRADES, ERECTION SEQUENCING AND CONSTRUCTABILITY.
6. THE CIVIL ENGINEER REVIEWS SUBMITTALS TO CONFIRM THAT THE SUBMITTAL IS IN GENERAL CONFORMANCE WITH THE DESIGN CONCEPT PRESENTED IN THE CONTRACT DOCUMENTS. QUANTITIES AND DIMENSIONS ARE NOT CHECKED. NOTATIONS ON SUBMITTALS DO NOT AUTHORIZE CHANGES TO THE CONTRACT SUM. CHECKING OF THE SUBMITTAL BY THE CIVIL ENGINEER SHALL NOT RELIEVE THE CONTRACTOR OF RESPONSIBILITY FOR DEVIATIONS FROM THE CONTRACT DOCUMENTS AND FROM ERRORS OR OMISSIONS IN THE SUBMITTAL.
7. IN ADDITION TO THE ABOVE, THE CIVIL ENGINEER'S REVIEW OF DELEGATED ENGINEER SUBMITTALS IS LIMITED TO VERIFYING THAT THE SPECIFIED CIVIL SUBMITTAL HAS BEEN FURNISHED, SIGNED AND SEALED BY THE DELEGATED ENGINEER AND THAT THE DELEGATED ENGINEER HAS UNDERSTOOD THE DESIGN INTENT AND USED THE SPECIFIED CIVIL CRITERIA. NO DETAILED CHECK OF CALCULATIONS WILL BE MADE. THE DELEGATED ENGINEER IS SOLELY RESPONSIBLE FOR HIS/HER DESIGN, INCLUDING BUT NOT LIMITED TO THE ACCURACY OF HIS/HER CALCULATIONS AND COMPLIANCE WITH THE APPLICABLE CODES AND STANDARDS.
8. CAD FILES OF CIVIL DRAWINGS MAY BE USED AS AN AID IN PREPARING SHOP DRAWINGS ONLY UPON THE CONTRACTOR SIGNING AN AGREEMENT. WHEN CAD FILES OR COPIES OF THE CIVIL DRAWINGS ARE MADE AVAILABLE, IT IS UNDER THE FOLLOWING CONDITIONS:
  - a. ALL INFORMATION CONTAINED IN THE CAD FILES OR COPIES OF THE CIVIL DRAWINGS ARE INSTRUMENTS OF SERVICE OF THE ARCHITECT/ENGINEER AND SHALL NOT BE USED FOR OTHER PROJECTS, ADDITIONS TO THE PROJECT OR THE COMPLETION OF THE PROJECT BY OTHERS. CAD FILES AND COPIES OF THE CIVIL DRAWINGS REMAIN THE PROPERTY OF DOMINICK R. PILLA ASSOCIATES AND IN NO CASE SHALL THEIR TRANSFER BE CONSIDERED A SALE.
  - b. CAD FILES OR COPIES OF THE CIVIL DRAWINGS ARE NOT CONTRACT DOCUMENTS. IN THE EVENT OF A CONFLICT, THE CIVIL DRAWINGS SHALL GOVERN.
  - c. THE USE OF CAD FILES OR COPIES OF THE CIVIL DRAWINGS SHALL NOT IN ANY WAY RELIEVE THE CONTRACTOR'S RESPONSIBILITY FOR PROPER CHECKING AND COORDINATION OF DIMENSIONS, DETAILS, SIZES AND QUANTITIES OF MATERIALS AS REQUIRED FOR THE PREPARATION OF COMPLETE AND ACCURATE SHOP DRAWINGS.
  - d. THE CONTRACTOR SHALL REVISE ALL REFERENCES TO CONTRACT DOCUMENT SHEET NUMBERS AND SECTION MARKS AND SHALL REMOVE INFORMATION THAT IS NOT REQUIRED FOR THEIR WORK FROM THE CAD FILES OR COPIES OF THE CIVIL DRAWINGS, INCLUDING THE TITLE BLOCK.
  - e. DIMENSIONS IN THE CAD FILES MAY NOT BE PRECISE AND, IN SOME CASES, HAVE BEEN INTENTIONALLY ALTERED FOR PRESENTATION PURPOSES. DO NOT SCALE DIMENSIONS ELECTRONICALLY OR OTHERWISE.

**SUBMITTALS REQUIRED:**

1. THE FOLLOWING ITEMS REQUIRE SUBMITTAL OF SHOP AND ERECTION DRAWINGS AND STRUCTURAL CALCULATIONS SIGNED AND SEALED BY A PROFESSIONAL ENGINEER REGISTERED IN THE STATE OF NEW YORK:
  - a. SUPPORT OF EXCAVATION.
  - b. PERMAVOID SPECIFICATIONS

**EXCAVATION, BACKFILL AND DEWATERING**

1. THE CONTRACTOR IS SOLELY RESPONSIBLE FOR ALL EXCAVATION PROCEDURES INCLUDING LAGGING, SHORING, AND PROTECTION OF ADJACENT PROPERTY, STRUCTURES, STREETS AND UTILITIES IN ACCORDANCE WITH THE REQUIREMENTS OF THE LOCAL BUILDING DEPARTMENT AND OSHA REGULATIONS. DO NOT EXCAVATE WITHIN ONE FOOT OF THE ANGLE OF REPOSE OF ANY SOIL BEARING FOUNDATION UNLESS THE FOUNDATION IS PROPERLY PROTECTED AGAINST SETTLEMENT.
2. DO NOT BACKFILL AGAINST WALLS UNTIL 7 DAYS AFTER THE WALLS ARE BRACED BY THE STRUCTURE OR ARE TEMPORARILY BRACED. DO NOT BACKFILL CANTILEVERED RETAINING WALLS UNTIL CONCRETE IS 7 DAYS OLD. DO NOT BACKFILL UNTIL AFTER COMPLETION AND INSPECTION OF ANY WATERPROOFING.
3. THE CONTRACTOR IS RESPONSIBLE FOR THE DISPOSAL OF ALL ACCUMULATED WATER IN A MANNER THAT DOES NOT INCONVENIENCE OR DAMAGE THE WORK.

**REINFORCED CONCRETE**

1. COMPLY WITH ACI 301 AND 318.
2. ALL CAST-IN-PLACE CONCRETE SHALL BE CONTROLLED CONCRETE AND SHALL HAVE A MINIMUM COMPRESSIVE STRENGTH (F<sub>c</sub>) AT 28 DAYS AS FOLLOWS:
 

|                    |                           |
|--------------------|---------------------------|
| FOOTINGS           | 4,000 PSI                 |
| POURED WALLS       | 4,000 PSI                 |
| SLABS-ON-GRADE     | 4,000 PSI                 |
| SLAB ON METAL DECK | 4,000 PSI (LT. WT. CONC.) |
3. USE NORMAL WEIGHT CONCRETE FOR ALL STRUCTURAL MEMBERS. U.O.N.
4. CONCRETE REINFORCEMENT SHALL BE ASTM A615, GRADE 60 DEFORMED REINFORCING STEEL. LAP BOTTOM STEEL OVER SUPPORTS AND TOP STEEL AT MIDSPAN (U.O.N.). HOOK DISCONTINUOUS ENDS OF ALL TOP BARS AND ALL BARS IN WALLS, U.O.N.
5. USE EPOXY COATED REINFORCEMENT CONFORMING TO ASTM A775 FOR CONCRETE SUBJECT TO WATER AND CHLORITE PENETRATION.
 

A.LOADING DOCK SLABS AND WALLS.
6. WHERE SPECIFIED, PROVIDE PLAIN, COLD-DRAWN ELECTRONICALLY WELDED WIRE REINFORCEMENT (WWF) CONFORMING TO ASTM A185. SUPPLY IN FLAT SHEETS ONLY. LAP SPLICE SHALL BE ONE CROSS WIRE SPACING PLUS TWO INCHES.
7. FOLLOW ACI 117-10 "SPECIFICATION FOR TOLERANCES OF CONCRETE CONSTRUCTION AND MATERIALS" FOR REQUIRED TOLERANCES.
8. UTILITIES SHALL NOT PENETRATE BEAMS OR COLUMNS BUT MAY PASS THROUGH SLABS AND WALLS INDIVIDUALLY, UON. SEE TYPICAL DETAILS.
9. PROVIDE CONSTRUCTION JOINTS IN ACCORDANCE WITH ACI 318, SECTION 6.4. PROVIDE KEYWAYS AND ADEQUATE DOWELS. SUBMIT DRAWINGS SHOWING LOCATION OF CONSTRUCTION JOINTS AND DIRECTION OF POUR FOR REVIEW.
10. PROVIDE 3/4" CHAMFER FOR ALL EXPOSED CORNERS. SEE ARCHITECTURAL DRAWINGS FOR ADDITIONAL CONCRETE FINISH REQUIREMENTS.

**CONCRETE FIELD TESTING:**

1. TESTING: OWNER WILL ENGAGE A QUALIFIED TESTING AGENCY TO PERFORM FIELD TESTS AND PREPARE TEST REPORTS.
2. CONCRETE TESTS: TESTING OF COMPOSITE SAMPLES OF FRESH CONCRETE OBTAINED ACCORDING TO ASTM C172 AND SECTION BC 1905.6.5 OF NYC BUILDING CODE SHALL BE PERFORMED ACCORDING TO THE FOLLOWING REQUIREMENTS:
  - a. TESTING FREQUENCY: OBTAIN ONE COMPOSITE SAMPLE FOR EACH DAY'S POUR OF EACH CONCRETE MIXTURE LESS THAN 25 CU. YD., PLUS ONE SET FOR EACH ADDITIONAL 50 CU. YD. OR FRACTION THEREOF.
  - b. WHEN FREQUENCY OF TESTING WILL PROVIDE FEWER THAN FIVE COMPRESSIVE STRENGTH TESTS OF EACH CONCRETE MIXTURE, TESTING SHALL BE CONDUCTED FROM AT LEAST FIVE RANDOMLY SELECTED BATCHES OR FROM EACH BATCH IF FEWER THAN FIVE ARE USED.
  - c. WATER CONTENT AND SLUMP: VERIFY WATER CONTENT IN ACCORDANCE WITH AASHTO t-318 "STANDARD METHOD OF TESTS FOR WATER CONTENT USING MICROWAVE OVEN DRYING." TEST SLUMP IN ACCORDANCE WITH ASTM C143; ONE TEST AT POINT OF PLACEMENT FOR EACH COMPOSITE SAMPLE, BUT NOT LESS THAN ONE TEST FOR EACH DAY'S POUR OF EACH CONCRETE MIXTURE. PERFORM ADDITIONAL TESTS WHEN CONCRETE CONSISTENCY APPEARS TO CHANGE.
  - d. AIR CONTENT: ASTM C231, PRESSURE METHOD, FOR NORMAL-WEIGHT CONCRETE; ASTM C173, VOLUMETRIC METHOD, FOR LIGHTWEIGHT CONCRETE; ONE TEST FOR EACH COMPOSITE SAMPLE, BUT NOT LESS THAN ONE TEST FOR EACH DAY'S POUR OF EACH CONCRETE MIXTURE.
  - e. CONCRETE TEMPERATURE: ASTM C1064; ONE TEST HOURLY WHEN AIR TEMPERATURE IS 40 DEG F AND BELOW AND WHEN 80 DEG F AND ABOVE, AND ONE TEST FOR EACH COMPOSITE SAMPLE.
  - f. COMPRESSION TEST SPECIMENS: ASTM C31.
    - i. CAST AND LABORATORY CURE ALL TEST CYLINDER SPECIMENS.
    - ii. WHEN REQUIRED, CAST AND FIELD CURE TWO SETS OF TWO STANDARD CYLINDER SPECIMENS FOR EACH COMPOSITE SAMPLE.
  - g. COMPRESSIVE-STRENGTH TESTS: ASTM C39 AND SECTION BC 1905.6.2 OF THE NYC BUILDING CODE; TEST FIRST SET OF TWO LABORATORY-CURED SPECIMENS AT 7 DAYS FOR INFORMATION, SECOND SET OF TWO LABORATORY-CURED SPECIMENS AT 28 DAYS FOR ACCEPTANCE AND THIRD SET OF TWO SPECIMENS AT 56 DAYS IF NECESSARY.
    - i. TEST ONE SET OF FIELD-CURED SPECIMENS AT 7 DAYS AND ONE SET OF TWO SPECIMENS AT 28 DAYS.
    - ii. A COMPRESSIVE-STRENGTH TEST SHALL BE THE AVERAGE COMPRESSIVE STRENGTH FROM A SET OF TWO SPECIMENS OBTAINED FROM SAME COMPOSITE SAMPLE AND TESTED AT AGE INDICATED.

**Ike Kligerman Barkley**

330 West Forty-Second Street  
New York, NY 10096  
212 268 0128

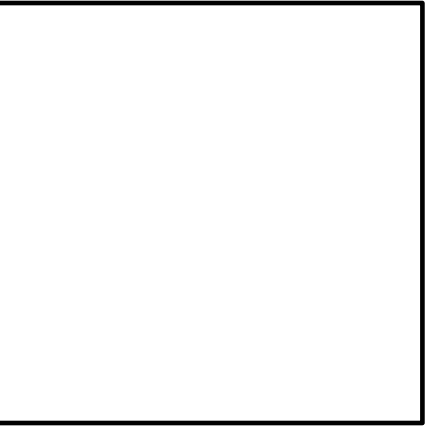

**59 TWEED BLVD.**

| No. | REMARKS    | DATE       |
|-----|------------|------------|
| 1   | REVISION 1 | 02/02/2022 |
| 2   |            |            |
| 3   |            |            |
|     |            |            |
|     |            |            |
|     |            |            |
|     |            |            |
|     |            |            |
|     |            |            |

PROJECT:  
**RESIDENCE**  
59 TWEED BOULEVARD  
ORANGEBURG, NY 10960



GENERAL NOTES

DATE: 02/02/2022  
PROJECT No.: 21-077  
DRAWING BY: JB  
CHK BY: GF  
DWG No.:

**C-002.00**

REFERENCE:  
1) LOT 40 BLOCK 1 SECTION 71.13 AS SHOWN ON THE TAX MAP OF TOWN OF ORANGETOWN, ROCKLAND COUNTY, NEW YORK.  
2) ALSO KNOWN AS PART OF SUBDIVISION MAP ENTITLED, "MINOR SUBDIVISION FOR ERNEST G. HESSE & ALICE W. HESSE IN UPPER GRANDVIEW, TOWN OF ORANGETOWN, ROCKLAND COUNTY-NEW YORK." DATED JULY 11, 1973.



59 TWEED BLVD.

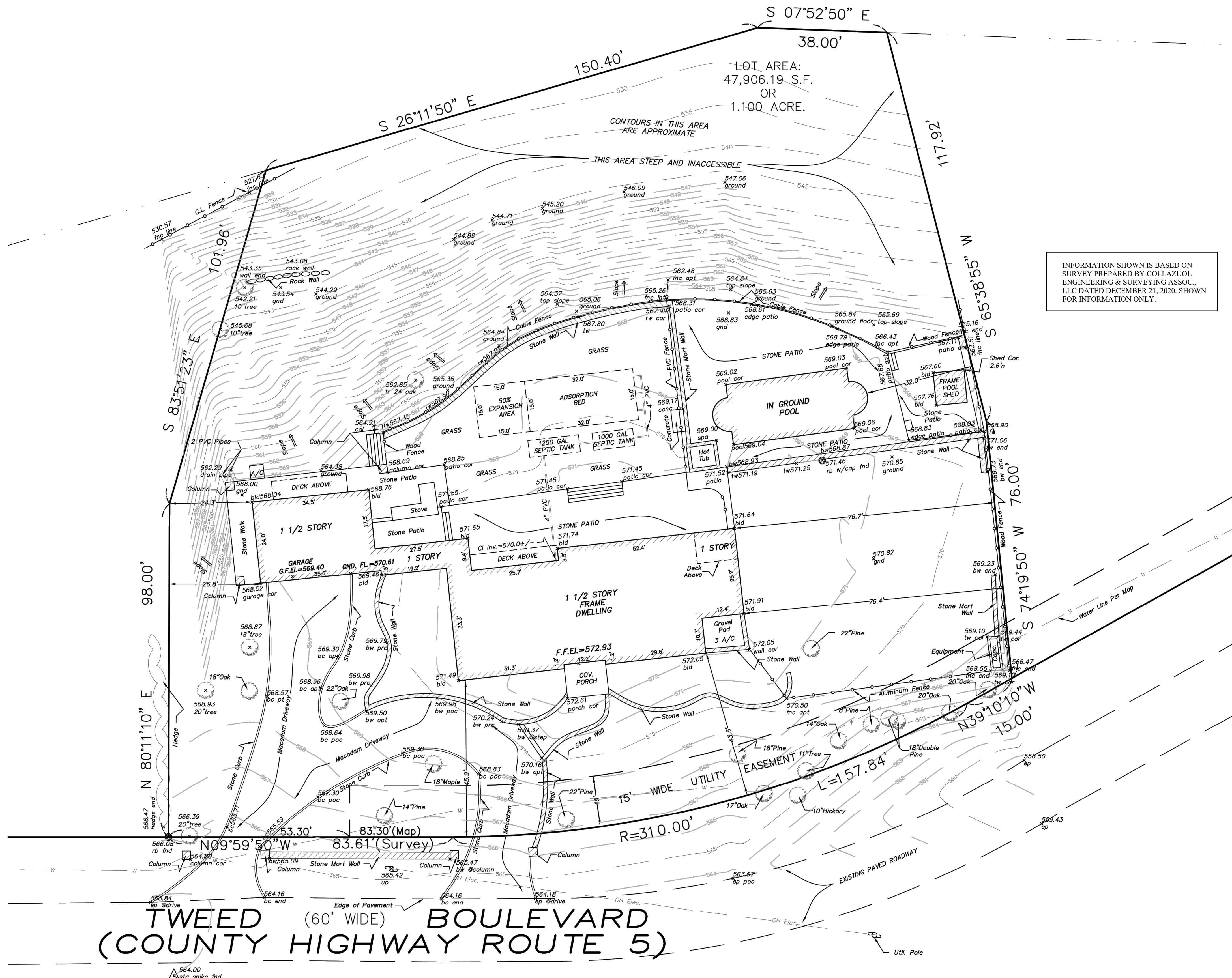

INFORMATION SHOWN IS BASED ON SURVEY PREPARED BY COLLAZUOL ENGINEERING & SURVEYING ASSOC., LLC DATED DECEMBER 21, 2020. SHOWN FOR INFORMATION ONLY.

UNAUTHORIZED ALTERATION OR ADDITION TO A SURVEY BEARING A LICENSED LAND SURVEYOR'S SEAL IS A VIOLATION OF SECTION 7209, SUB-DIVISION 2, OF THE NEW YORK STATE EDUCATION LAW.

ONLY COPIES FROM THE ORIGINAL OF THIS SURVEY MARKED WITH AN ORIGINAL OF THE LAND SURVEYOR'S EMBOSSED SEAL SHALL BE CONSIDERED TO BE VALID TRUE COPIES.

CERTIFICATIONS INDICATED HEREON SIGNIFY THAT THIS SURVEY WAS PREPARED IN ACCORDANCE WITH THE EXISTING CODE OF PRACTICE FOR LAND SURVEYS ADOPTED BY THE NEW YORK STATE ASSOCIATION OF PROFESSIONAL LAND SURVEYORS. SAID CERTIFICATIONS SHALL RUN ONLY TO THE PERSON FOR WHOM THE SURVEY IS PREPARED, AND ON HIS BEHALF TO THE TITLE COMPANY, GOVERNMENTAL AGENCY AND LENDING INSTITUTION LISTED HEREON. CERTIFICATIONS ARE NOT TRANSFERABLE TO ADDITIONAL INSTITUTIONS OR SUBSEQUENT OWNERS.

IT IS A VIOLATION OF THE STATE EDUCATION LAW FOR ANY PERSON, UNLESS ACTING UNDER THE DIRECTION OF A LICENSED LAND SURVEYOR, TO ALTER AN ITEM IN ANY WAY.

ONLY COPIES OF THIS SURVEY MARKED WITH THE LAND SURVEYOR'S SIGNATURE AND AN ORIGINAL EMBOSSED OR INKED SEAL ARE THE PRODUCT OF THE LAND SURVEYOR.

THIS SURVEY WAS PREPARED FOR THE PARTIES AND PURPOSE INDICATED HEREON. ANY EXTENSION OF THE USE BEYOND THE PURPOSE AGREED TO BETWEEN THE CLIENT AND THE SURVEYOR EXCEEDS THE SCOPE OF THE ENGAGEMENT.

SUBJECT TO THE FINDINGS OF AN ACCURATE TITLE REPORT.

| No. | REMARKS    | DATE       |
|-----|------------|------------|
| 1   | REVISION 1 | 02/02/2022 |
| 2   |            |            |
| 3   |            |            |

PROJECT:  
**RESIDENCE**  
59 TWEED BOULEVARD  
ORANGETOWN, NY 10966



EXISTING SURVEY AT  
59 TWEED BLVD

DATE: 02/02/2022  
PROJECT No.: 21-077  
DRAWING BY: JB  
CHK BY: GF  
DWG No.:

C-003.00

TWEED (60' WIDE) BOULEVARD  
(COUNTY HIGHWAY ROUTE 5)

A EXISTING SURVEY  
SCALE: 1/16"=1'-0"

| ABT PERMAVOID 150 SCHEDULE |                         |        |               |                     |                              |                             |                                |
|----------------------------|-------------------------|--------|---------------|---------------------|------------------------------|-----------------------------|--------------------------------|
| ZONE                       | SOURCE                  | SIZE   | # OF CHAMBERS | OVERALL SYSTEM SIZE | SYSTEM INVERT ELEVATION (FT) | INLET INVERT ELEVATION (FT) | OVERFLOW INVERT ELEVATION (FT) |
| 1                          | DRIVEWAY AND PATIO      | 6 HIGH | 234           | 41.81'X15.10'X2.95' | 562.64                       | 565.09                      | 565.09                         |
| 2                          | PATIO & POOL HOUSE ROOF | 6 HIGH | 180           | 46.46'X10.45'X2.95' | 563.64                       | 566.09                      | 566.09                         |

| SUBCATCHMENT AREAS |          |          |
|--------------------|----------|----------|
| AREAS (SQFT)       | EXISTING | PROPOSED |
| TOTAL AREA         | 47,906   | 47,906   |
| ROOF AREA          | 4,184    | 5,464    |
| IMPERVIOUS AREA    | 9,469    | 9,181    |
| PERVIOUS AREA      | 34,253   | 33,261   |

| LEGEND |                                  |
|--------|----------------------------------|
|        | PROPERTY LINE                    |
|        | ROOF AREA                        |
|        | IMPERVIOUS AREA                  |
|        | POLYDRAIN PAVERGRATE             |
|        | NEW CONTOURS                     |
|        | EXISTING CONTOURS                |
|        | NEW STORMWATER DRAIN LINE        |
|        | EXISTING OVERHEAD WIRES          |
|        | PROPOSED PLANTING BED            |
|        | POLYDRAIN FIRSTFLUSH CATCH BASIN |
|        | DETENTION SYSTEM ZONE 1          |
|        | DETENTION SYSTEM ZONE 2          |
|        | BORING LOCATION AND NUMBER       |
|        | TEST PIT LOCATION AND NUMBER     |

- GENERAL NOTES**
- ALL WORK AND MATERIALS SHALL COMPLY WITH NEW YORK DOT REGULATIONS AND CODES AND OSHA STANDARDS. THE CONTRACTOR SHALL OBTAIN FINAL PERMITTING AND APPROVAL INSPECTIONS AS REQUIRED FROM THE LOCALITY. THE CONTRACTOR SHALL VERIFY ELEVATIONS AT CONNECTION POINTS OR ANY EXISTING UTILITY CROSSING PRIOR TO ORDERING STRUCTURES. REPORT ANY CONFLICTS TO THE ENGINEER.
  - ALL UNDERGROUND SHALL BE INSTALLED, INSPECTED AND APPROVED PRIOR TO BACKFILLING.
  - THE CONTRACTOR IS RESPONSIBLE FOR THE REPAIRS TO UTILITIES DAMAGED DURING CONSTRUCTION AT NO COST TO THE OWNER.
  - STORM SEWER CATCH BASINS, CURB INLETS MANHOLES AND ENDWALLS SHALL CONFORM TO NEW YORK DOT STANDARD CONSTRUCTION DRAWINGS.
  - ALL SPOT ELEVATIONS REFER TO FINISHED PAVEMENT ELEVATION UNLESS OTHERWISE NOTED.
  - PROVIDE 2% MAXIMUM CROSS SLOPE ON ALL SIDEWALKS AND ADA PARKING AREAS.
  - CONTRACTOR SHALL APPLY EROSION CONTROL BLANKET AND LOW MAINTENANCE GRASS SEED MIX TO ALL SLOPES 3H:1V OR GREATER. REFER TO SOIL EROSION AND SEDIMENT CONTROL DETAIL FOR LOW MAINTENANCE GRASS SEED MIXTURES SPECIFICATION.
  - REFER TO GEOTECHNICAL REPORT FOR SUBGRADE PREPARATION.
  - AREA OF DISTURBANCE = 26,495 SQFT

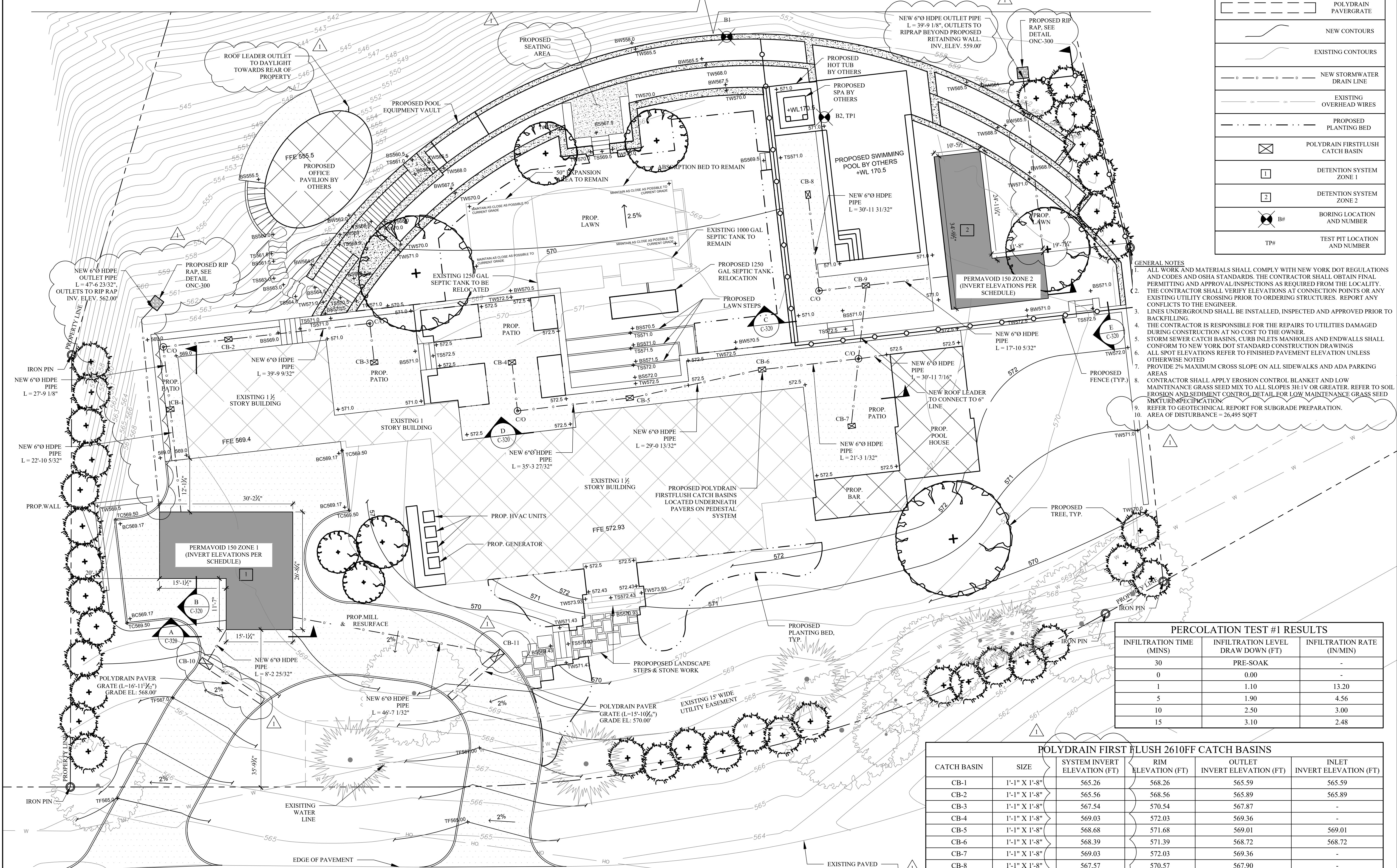

**59 TWEED BLVD.**

| No. | REMARKS    | DATE       |
|-----|------------|------------|
| 1   | REVISION 1 | 02/02/2022 |
| 2   |            |            |
| 3   |            |            |

PROJECT:  
**RESIDENCE**  
 59 TWEED BOULEVARD  
 ORANGEBURG, NY 10960



| PERCOLATION TEST #1 RESULTS |                                   |                            |
|-----------------------------|-----------------------------------|----------------------------|
| INFILTRATION TIME (MINS)    | INFILTRATION LEVEL DRAW DOWN (FT) | INFILTRATION RATE (IN/MIN) |
| 30                          | PRE-SOAK                          | -                          |
| 0                           | 0.00                              | -                          |
| 1                           | 1.10                              | 13.20                      |
| 5                           | 1.90                              | 4.56                       |
| 10                          | 2.50                              | 3.00                       |
| 15                          | 3.10                              | 2.48                       |

| POLYDRAIN FIRST FLUSH 2610FF CATCH BASINS |               |                              |                    |                              |                             |
|---|---------------|------------------------------|--------------------|------------------------------|-----------------------------|
| CATCH BASIN                               | SIZE          | SYSTEM INVERT ELEVATION (FT) | RIM ELEVATION (FT) | OUTLET INVERT ELEVATION (FT) | INLET INVERT ELEVATION (FT) |
| CB-1                                      | 1'-1" X 1'-8" | 565.26                       | 568.26             | 565.59                       | 565.59                      |
| CB-2                                      | 1'-1" X 1'-8" | 565.56                       | 568.56             | 565.89                       | 565.89                      |
| CB-3                                      | 1'-1" X 1'-8" | 567.54                       | 570.54             | 567.87                       | -                           |
| CB-4                                      | 1'-1" X 1'-8" | 569.03                       | 572.03             | 569.36                       | -                           |
| CB-5                                      | 1'-1" X 1'-8" | 568.68                       | 571.68             | 569.01                       | 569.01                      |
| CB-6                                      | 1'-1" X 1'-8" | 568.39                       | 571.39             | 568.72                       | 568.72                      |
| CB-7                                      | 1'-1" X 1'-8" | 569.03                       | 572.03             | 569.36                       | -                           |
| CB-8                                      | 1'-1" X 1'-8" | 567.57                       | 570.57             | 567.90                       | -                           |
| CB-9                                      | 1'-1" X 1'-8" | 567.26                       | 570.26             | 567.59                       | 567.59                      |
| CB-10                                     | 1'-1" X 1'-8" | 565.00                       | 568.00             | 565.33                       | -                           |
| CB-11                                     | 1'-1" X 1'-8" | 567.00                       | 570.00             | 567.33                       | -                           |

**A PROPOSED SITE AND DRAINAGE PLAN**  
 SCALE: 1"=10'

**TWEED BOULEVARD**  
 (COUNTY HIGHWAY ROUTE 5)  
 (60' WIDE)

PROPOSED SITE AND DRAINAGE PLAN

DATE: 02/02/2022  
 PROJECT No.: 21-077  
 DRAWING BY: JB  
 CHK BY: GF  
 DWG No.:

**C-100.01**

| LEGEND |                         |
|--------|-------------------------|
|        | PROPERTY LINE           |
|        | ROOF AREA               |
|        | IMPERVIOUS AREA         |
|        | GRASS AREA              |
|        | EXISTING WALL           |
|        | EXISTING CONTOURS       |
|        | EXISTING OVERHEAD WIRES |

GENERAL NOTES  
 1. TREES ARE NOT SHOWN FOR CLARITY.  
 2. AREA OF DISTURBANCE = 26,495 SQFT

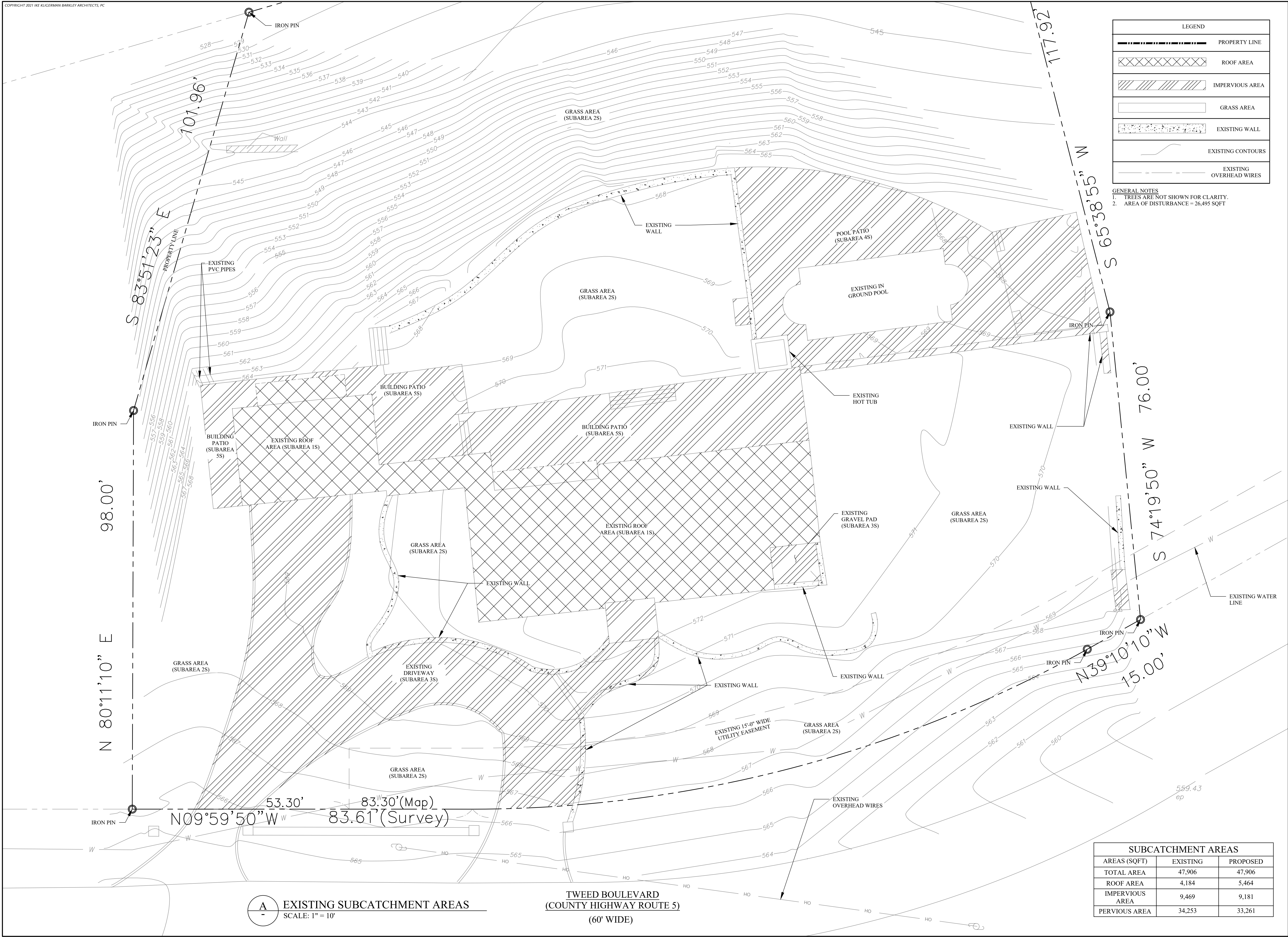

**59 TWEED BLVD.**

| No. | REMARKS    | DATE       |
|-----|------------|------------|
| 1   | REVISION 1 | 02/02/2022 |
| 2   |            |            |
| 3   |            |            |

PROJECT:  
**RESIDENCE**  
 59 TWEED BOULEVARD  
 ORANGEBURG, NY 10960



EXISTING SUBCATCHMENT AREAS

| SUBCATCHMENT AREAS |          |          |
|--------------------|----------|----------|
| AREAS (SQFT)       | EXISTING | PROPOSED |
| TOTAL AREA         | 47,906   | 47,906   |
| ROOF AREA          | 4,184    | 5,464    |
| IMPERVIOUS AREA    | 9,469    | 9,181    |
| PERVIOUS AREA      | 34,253   | 33,261   |

DATE: 02/02/2022  
 PROJECT No.: 21-077  
 DRAWING BY: JB  
 CHK BY: GF  
 DWG No.:  
**C-101.00**

**A** EXISTING SUBCATCHMENT AREAS  
 SCALE: 1" = 10'

**TWEED BOULEVARD**  
 (COUNTY HIGHWAY ROUTE 5)  
 (60' WIDE)

N 80°11'10" E 98.00'

N09°59'50" W 53.30'  
 83.30' (Map)  
 83.61' (Survey)

N39°10'10" W 15.00'

S 74°19'50" W 76.00'

S 65°38'55" W 117.92'

S 83°51'23" E 101.96'

| LEGEND |                         |
|--------|-------------------------|
|        | PROPERTY LINE           |
|        | ROOF AREA               |
|        | IMPERVIOUS AREA         |
|        | GRASS AREA              |
|        | PROPOSED WALL           |
|        | NEW CONTOURS            |
|        | EXISTING CONTOURS       |
|        | EXISTING OVERHEAD WIRES |

GENERAL NOTES  
 1. TREES ARE NOT SHOWN FOR CLARITY.  
 2. AREA OF DISTURBANCE = 26,495 SQFT

| SUBCATCHMENT AREAS |          |          |
|--------------------|----------|----------|
| AREAS (SQFT)       | EXISTING | PROPOSED |
| TOTAL AREA         | 47,906   | 47,906   |
| ROOF AREA          | 4,184    | 5,464    |
| IMPERVIOUS AREA    | 9,469    | 9,181    |
| PERVIOUS AREA      | 34,253   | 33,261   |

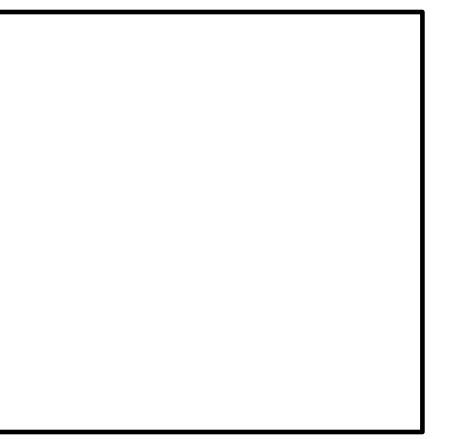

**59 TWEED BLVD.**

| No. | REMARKS    | DATE       |
|-----|------------|------------|
| 1   | REVISION 1 | 02/02/2022 |
| 2   |            |            |
| 3   |            |            |

PROJECT:  
**RESIDENCE**  
 59 TWEED BOULEVARD  
 ORANGEBURG, NY 10960

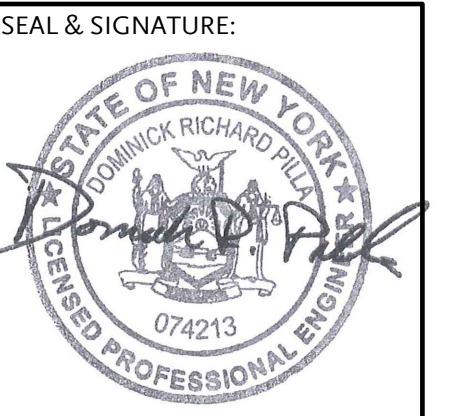

PROPOSED  
 SUBCATCHMENT AREAS

DATE: 02/02/2022  
 PROJECT No.: 21-077  
 DRAWING BY: JB  
 CHK BY: GF  
 DWG No.:

**C-102.00**

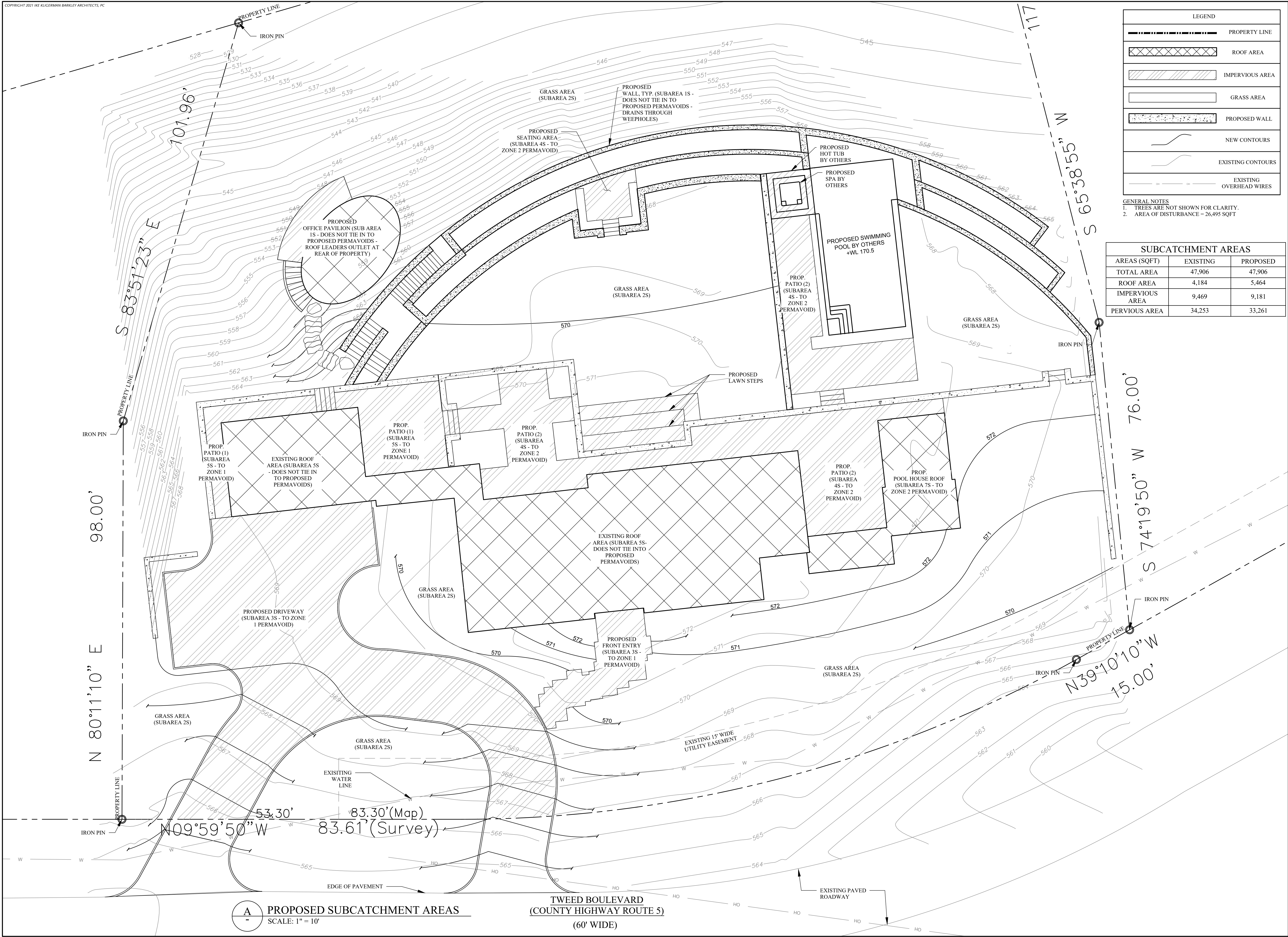

**A** PROPOSED SUBCATCHMENT AREAS  
 SCALE: 1" = 10'

TWEED BOULEVARD  
 (COUNTY HIGHWAY ROUTE 5)  
 (60' WIDE)

**59 TWEED BLVD.**

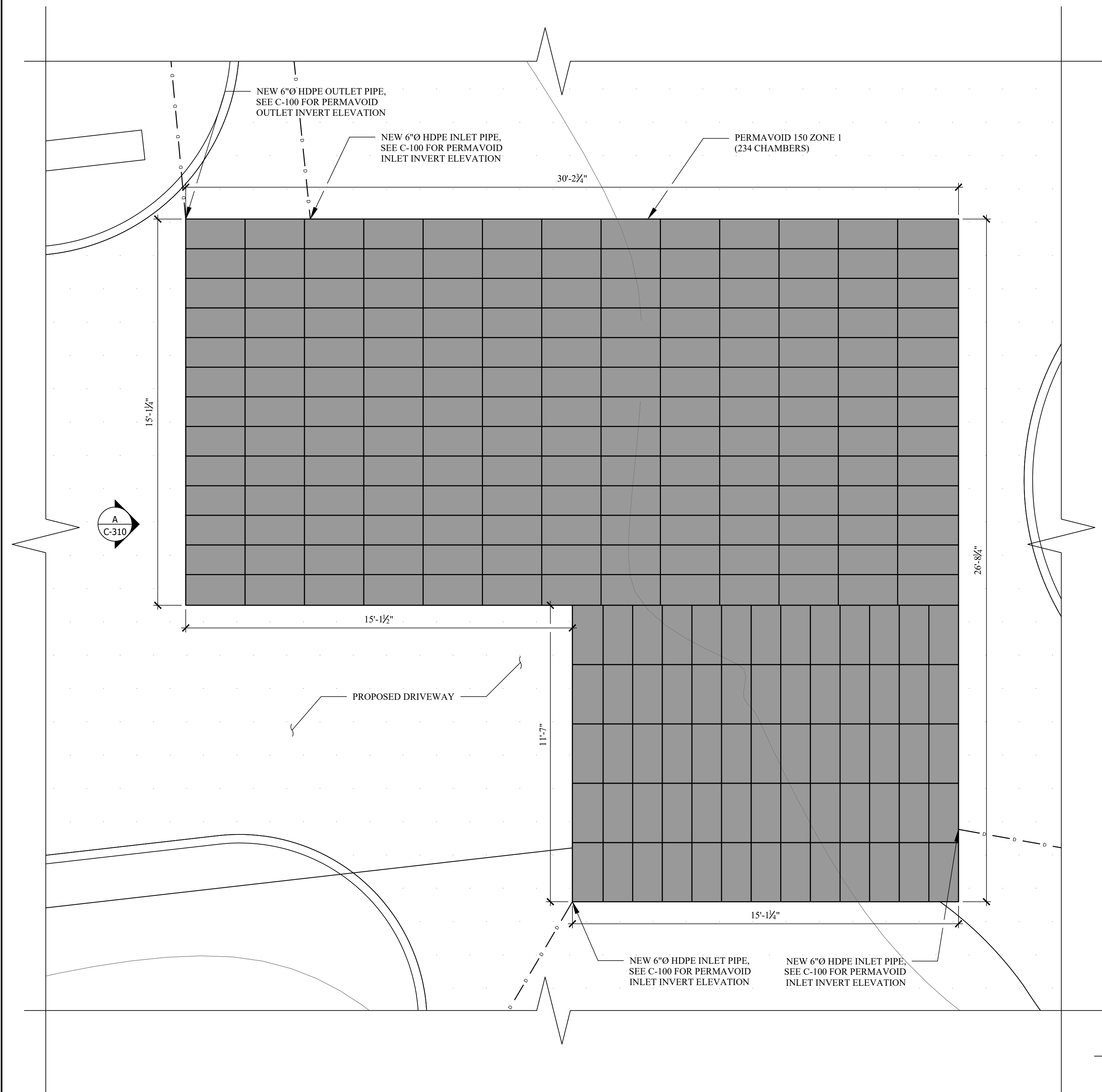

**A PERMAVOID 150 ZONE 1**  
SCALE: 3/8" = 1'-0"

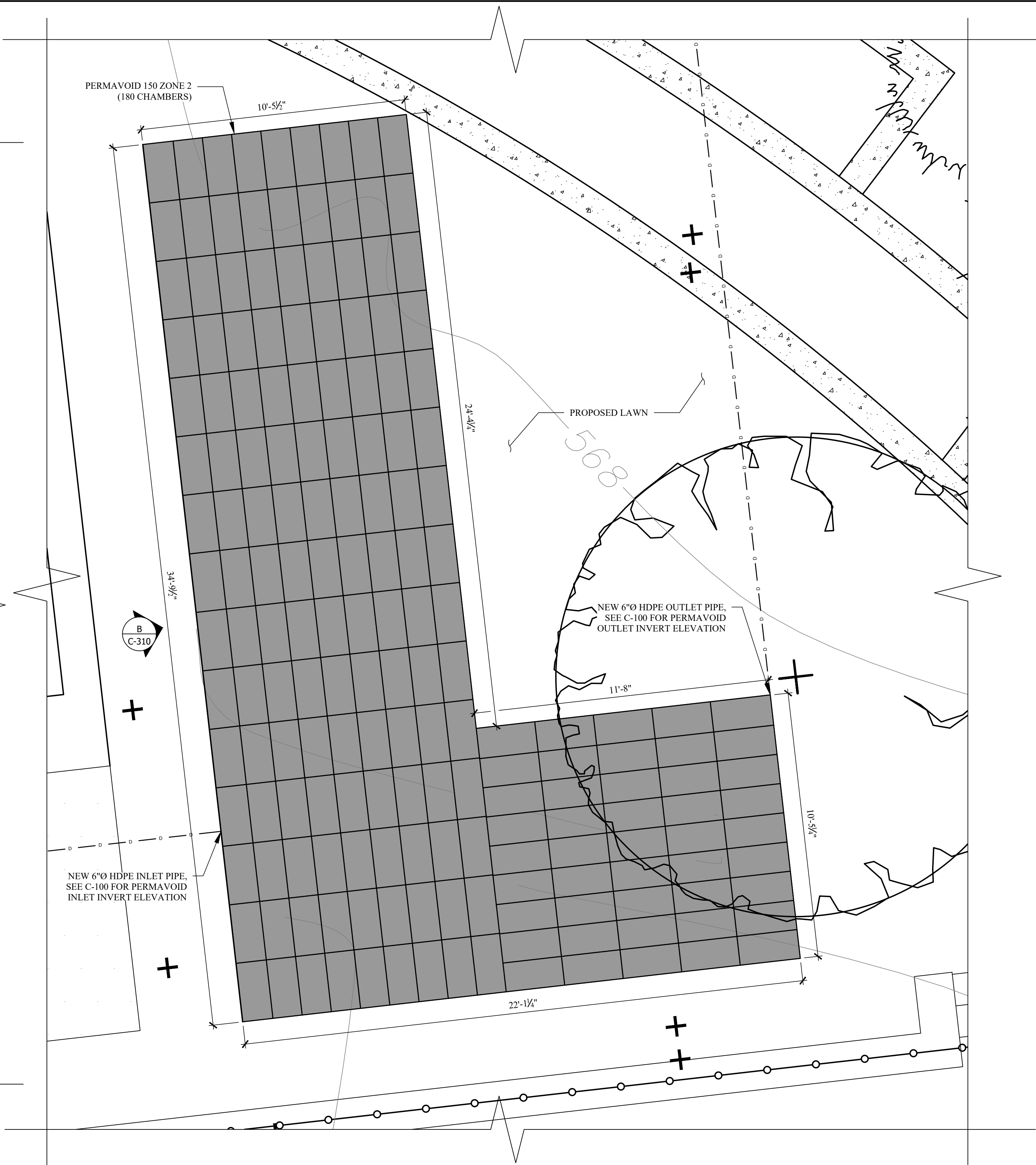
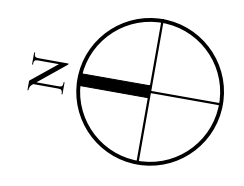

**B PERMAVOID 150 ZONE 2**  
SCALE: 3/8" = 1'-0"

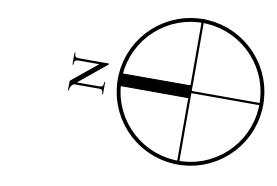

| LEGEND |                           |
|--------|---------------------------|
|        | PROPERTY LINE             |
|        | NEW CONCRETE WALL         |
|        | IMPERVIOUS AREA           |
|        | NEW PERMAVOID CHAMBER     |
|        | NEW CONTOURS              |
|        | EXISTING CONTOURS         |
|        | NEW STORMWATER DRAIN LINE |

- GENERAL NOTES**
- ALL WORK AND MATERIALS SHALL COMPLY WITH NEW YORK DOT REGULATIONS AND CODES AND OSHA STANDARDS. THE CONTRACTOR SHALL OBTAIN FINAL PERMITTING AND APPROVAL/INSPECTIONS AS REQUIRED FROM THE LOCALITY.
  - THE CONTRACTOR SHALL VERIFY ELEVATIONS AT CONNECTION POINTS OR ANY EXISTING UTILITY CROSSING PRIOR TO ORDERING STRUCTURES. REPORT ANY CONFLICTS TO THE ENGINEER.
  - ALL LINES UNDERGROUND SHALL BE INSTALLED, INSPECTED AND APPROVED PRIOR TO BACKFILLING.
  - THE CONTRACTOR IS RESPONSIBLE FOR THE REPAIRS TO UTILITIES DAMAGED DURING CONSTRUCTION AT NO COST TO THE OWNER.
  - STORM SEWER CATCH BASINS, CURB INLETS MANHOLES AND ENDWALLS SHALL CONFORM TO NEW YORK DOT STANDARD CONSTRUCTION DRAWINGS.
  - ALL SPOT ELEVATIONS REFER TO FINISHED PAVEMENT ELEVATION UNLESS OTHERWISE NOTED.
  - PROVIDE 2% MAXIMUM CROSS SLOPE ON ALL SIDEWALKS AND ADA PARKING AREAS.
  - CONTRACTOR SHALL APPLY EROSION CONTROL BLANKET AND LOW MAINTENANCE GRASS SEED MIX TO ALL SLOPES 3H:1V OR GREATER. REFER TO SOIL EROSION AND SEDIMENT CONTROL DETAIL FOR LOW MAINTENANCE GRASS SEED MIXTURE SPECIFICATION.
  - REFER TO GEOTECHNICAL REPORT FOR SUBGRADE PREPARATION.
  - AREA OF DISTURBANCE = 26,495 SQFT

| No. | REMARKS    | DATE       |
|-----|------------|------------|
| 1   | REVISION 1 | 02/02/2022 |
| 2   |            |            |
| 3   |            |            |

PROJECT:  
**RESIDENCE**  
59 TWEED BOULEVARD  
ORANGEBURG, NY 10960



PROPOSED  
DETENTION SYSTEMS

DATE: 02/02/2022  
PROJECT No.: 21-077  
DRAWING BY: JB  
CHK BY: GF  
DWG No.:

**C-110.00**

| LEGEND |                             |
|--------|-----------------------------|
|        | PROPERTY LINE               |
|        | EXISTING TO REMAIN          |
|        | EXISTING TO BE REMOVED      |
|        | EXISTING EASEMENT           |
|        | EXISTING TREE TO REMAIN     |
|        | EXISTING TREE TO BE REMOVED |
|        | EXISTING CONTOURS           |

NOTE:  
1. AREA OF DISTURBANCE = 26,495 SQFT

LOT AREA:  
47,906 SQFT  
OR  
1.100 ACRE

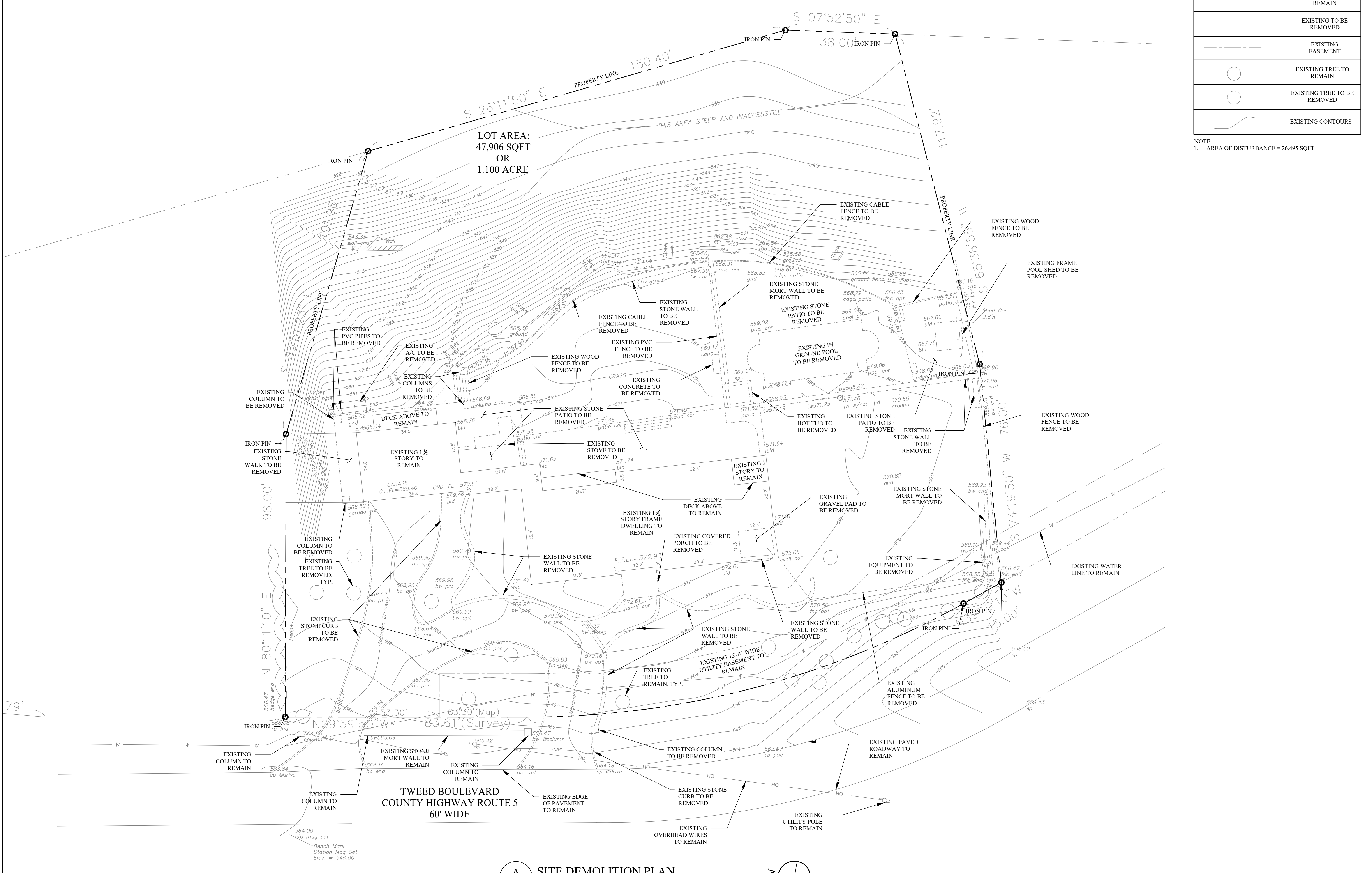

59 TWEED BLVD.

| No. | REMARKS    | DATE       |
|-----|------------|------------|
| 1   | REVISION 1 | 02/02/2022 |
| 2   |            |            |
| 3   |            |            |

PROJECT:  
**RESIDENCE**  
59 TWEED BOULEVARD  
ORANGEBURG, NY 10960



SITE DEMOLITION PLAN

DATE: 02/02/2022  
PROJECT No.: 21-077  
DRAWING BY: JB  
CHK BY: GF  
DWG No.:

C-200.00

**A** SITE DEMOLITION PLAN  
SCALE: 1" = 15'



| TREE REMOVAL SCHEDULE |         |                        |         |
|-----------------------|---------|------------------------|---------|
| TREE NUMBER           | SIZE    | SPECIES                | ACTION  |
| 1                     | UNKNOWN | UNKNOWN                | PROTECT |
| 2                     | UNKNOWN | UNKNOWN                | REMOVE  |
| 3                     | 18"     | QUERCUS SP.            | REMOVE  |
| 4                     | UNKNOWN | UNKNOWN                | REMOVE  |
| 5                     | 22"     | QUERCUS SP.            | REMOVE  |
| 6                     | 14"     | PINUS SP.              | PROTECT |
| 7                     | 18"     | ACER SP.               | PROTECT |
| 8                     | 22"     | PINUS SP.              | PROTECT |
| 9                     | 18"     | PINUS SP.              | PROTECT |
| 10                    | 17"     | QUERCUS SP.            | PROTECT |
| 11                    | 10"     | CARYA SP.              | PROTECT |
| 12                    | 11"     | UNKNOWN                | PROTECT |
| 13                    | 14"     | QUERCUS SP.            | PROTECT |
| 14                    | 22"     | PINUS SP.              | REMOVE  |
| 15                    | 8"      | PINUS SP.              | PROTECT |
| 16                    | 18"     | PINUS SP. (MULTI-STEM) | PROTECT |
| 17                    | 20"     | QUERCUS SP.            | PROTECT |
| 18                    | 20"     | QUERCUS SP.            | PROTECT |
| 19                    | UNKNOWN | UNKNOWN                | REMOVE  |

**LEGEND**

- PROPERTY LINE
- SILT FENCE
- LIMIT OF DISTURBANCE
- PROPOSED POLYDRAIN PAVERGRATE
- NEW STORMWATER DRAIN LINE
- PROPOSED POLYDRAIN FIRSTFLUSH CATCH BASIN
- PROPOSED DETENTION SYSTEM ZONE 1
- PROPOSED DETENTION SYSTEM ZONE 2
- EXISTING TREE, SEE TREE REMOVAL SCHEDULE
- PROPOSED DROP INLET PROTECTION
- PROPOSED TREE PROTECTION

NOTE:  
 1. AREA OF DISTURBANCE = 26,495 SQFT

**59 TWEED BLVD.**

| No. | REMARKS    | DATE       |
|-----|------------|------------|
| 1   | REVISION 1 | 02/02/2022 |
| 2   |            |            |
| 3   |            |            |

PROJECT:  
**RESIDENCE**  
 59 TWEED BOULEVARD  
 ORANGEBURG, NY 10960



SOIL EROSION AND SEDIMENT CONTROL PLAN

DATE: 02/02/2022  
 PROJECT No.: 21-077  
 DRAWING BY: JB  
 CHK BY: GF  
 DWG No.:

**C-210.01**

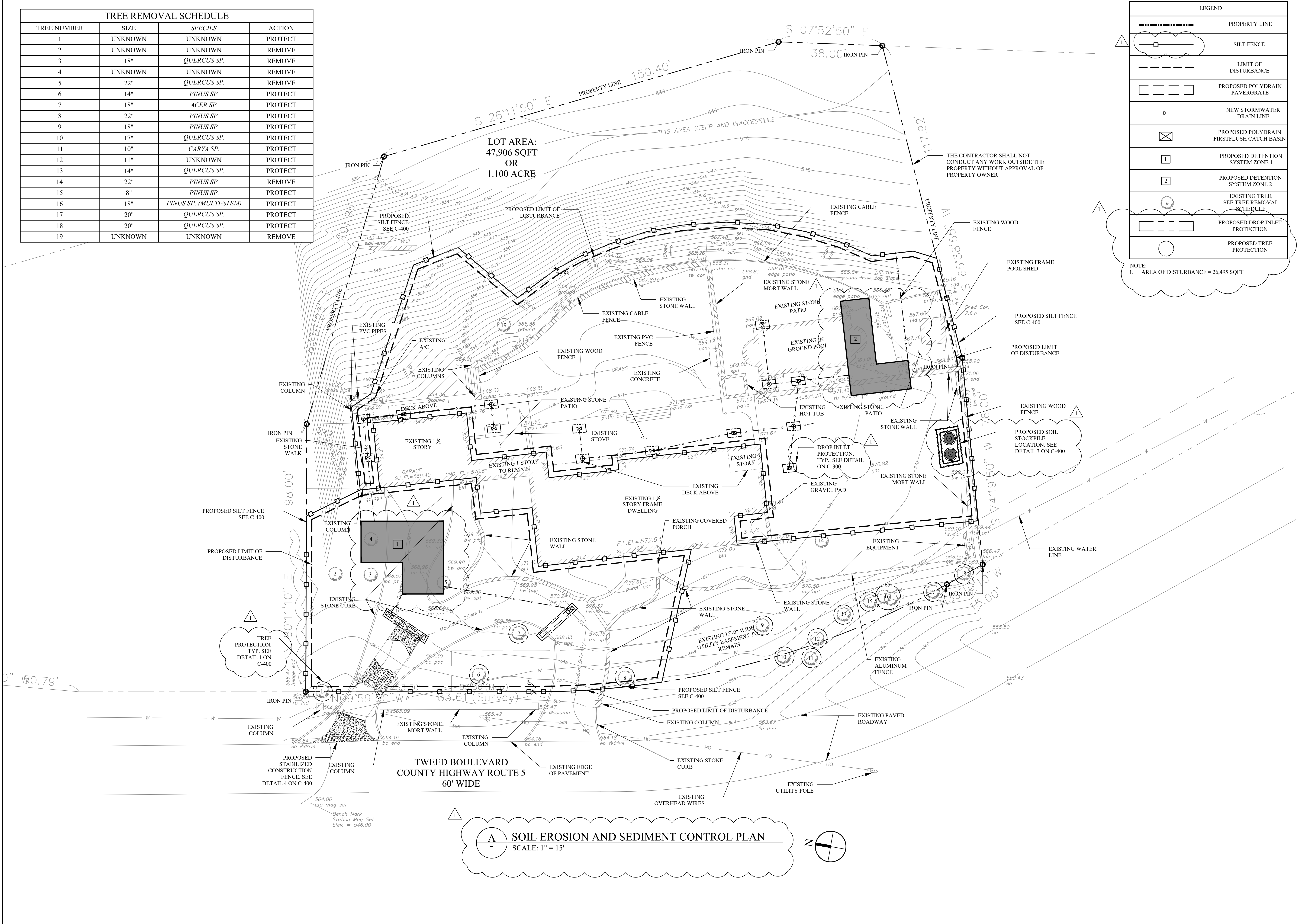

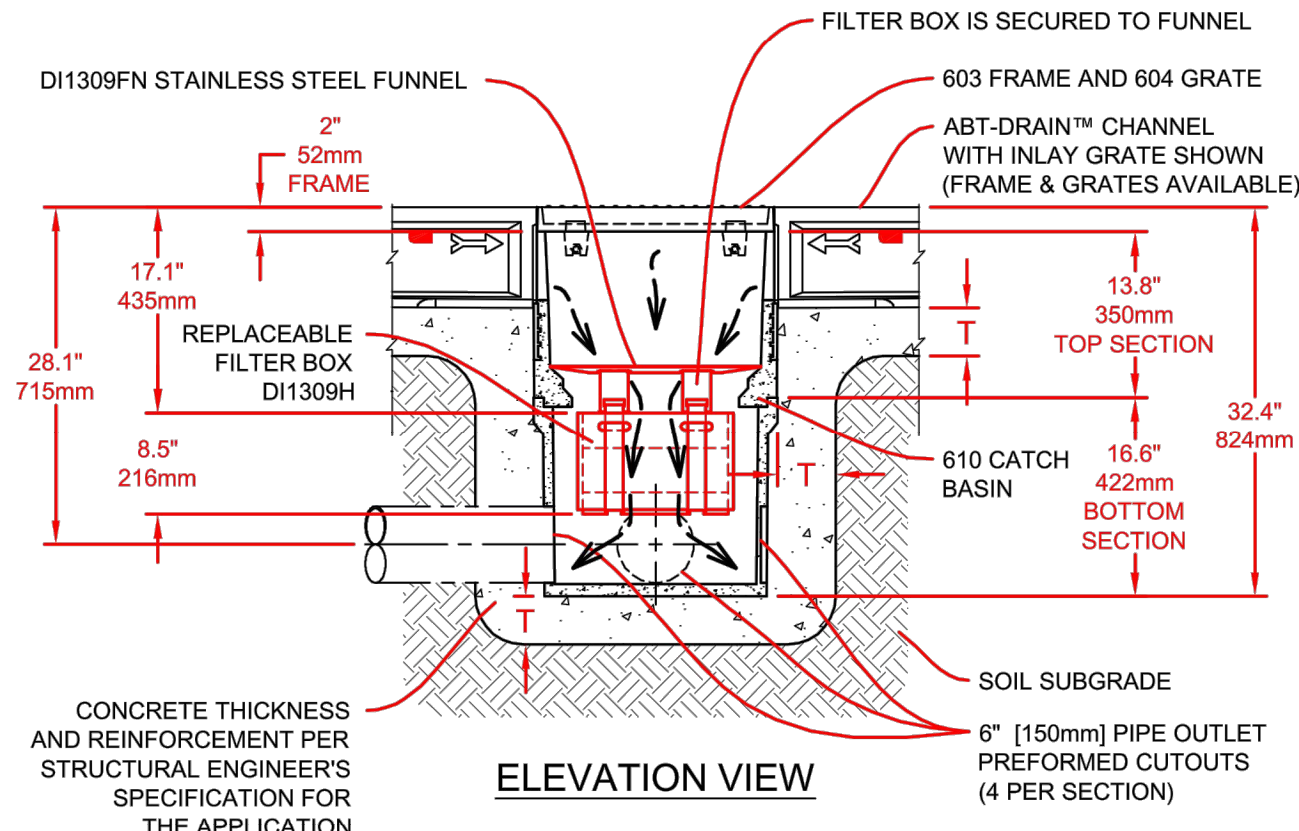
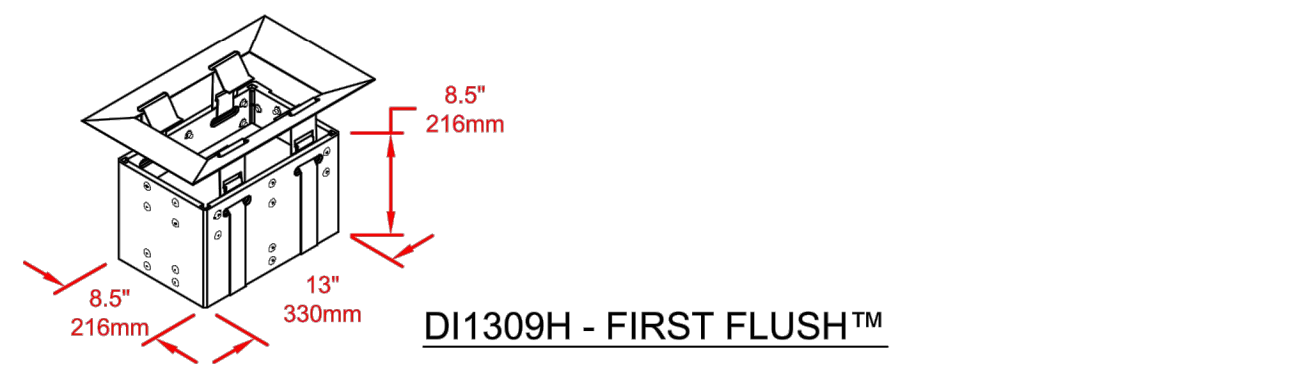

**ELEVATION VIEW**

REPLACEABLE FILTER BOX DI1309H

610 CATCH BASIN

SOIL SUBGRADE

6\"/>

**ABT, Inc.**  
 P.O. BOX 837, 259 MURDOCK ROAD  
 TROUTMAN, NC 28166  
 (704) 526-9100

FILE: **S-DI1309H-00** PART: **DI1309H, DI1309FN**

Proprietary rights of ABT, Inc. are included in the information disclosed herein. The recipient, by accepting this document, agrees that neither this document nor the information disclosed herein nor any part thereof shall be copied, reproduced or transferred to others for manufacturing or for any other purpose except as specifically authorized in writing by ABT, Inc.

DISCLAIMER: The customer and the customer's architect, engineer, consultant and other professionals are completely responsible for the selection, installation, and maintenance of any product purchased from ABT, and EXCEPT AS EXPRESSLY PROVIDED IN ABT'S STANDARD WARRANTIES, ABT MAKES NO WARRANTY, EXPRESS OR IMPLIED, AS TO THE SUITABILITY, DESIGN, MERCHANTABILITY, OR FITNESS OF THE PRODUCT FOR CUSTOMER'S APPLICATION. Copies of ABT's standard warranties are available upon request.

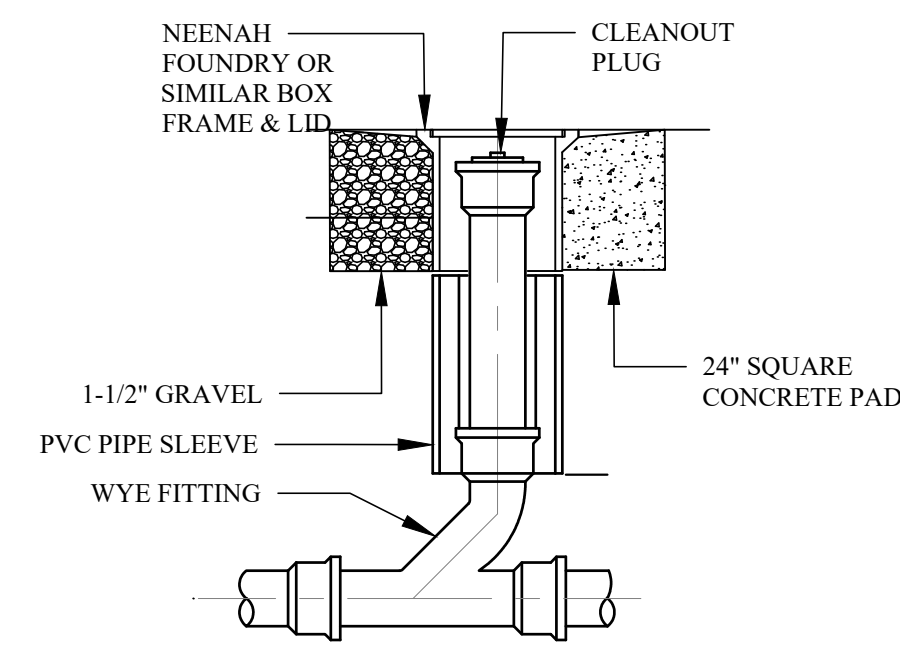

**TYP. CLEANOUT DETAIL**  
 SCALE: 1/2" = 1'-0"

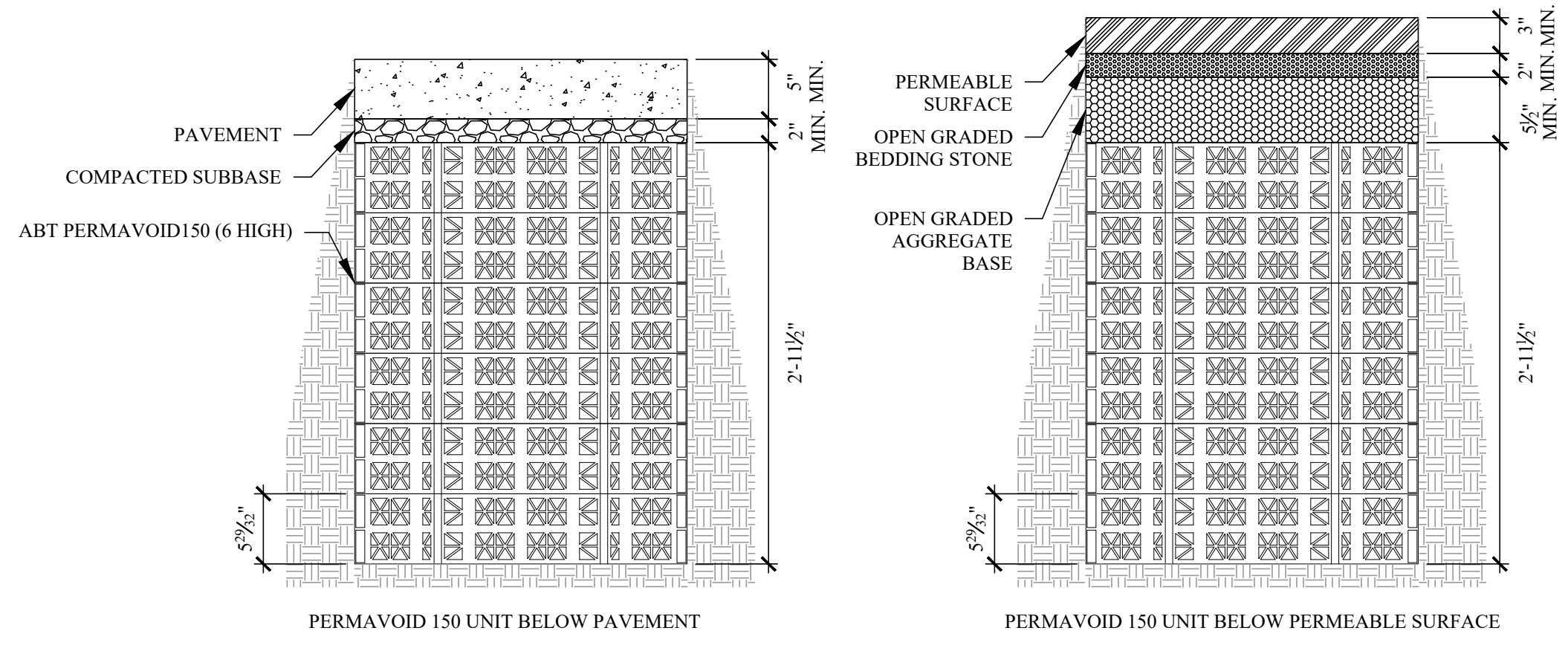

**PERMAVOID 150 UNIT SOIL CONTACT DETAIL**  
 SCALE: 1" = 1'-0"

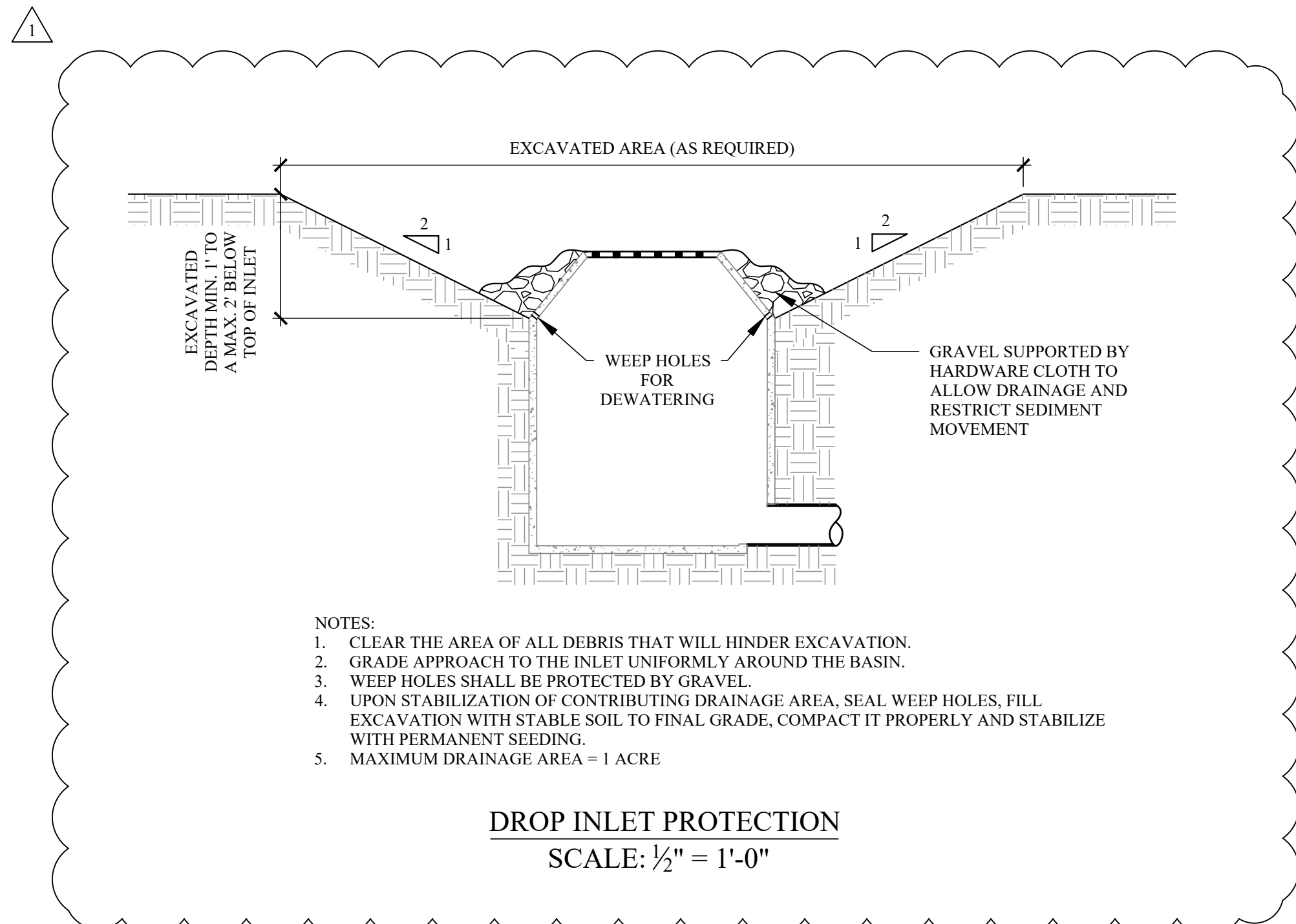

- NOTES:**
1. CLEAR THE AREA OF ALL DEBRIS THAT WILL HINDER EXCAVATION.
  2. GRADE APPROACH TO THE INLET UNIFORMLY AROUND THE BASIN.
  3. WEEP HOLES SHALL BE PROTECTED BY GRAVEL.
  4. UPON STABILIZATION OF CONTRIBUTING DRAINAGE AREA, SEAL WEEP HOLES, FILL EXCAVATION WITH STABLE SOIL TO FINAL GRADE, COMPACT IT PROPERLY AND STABILIZE WITH PERMANENT SEEDING.
  5. MAXIMUM DRAINAGE AREA = 1 ACRE

**DROP INLET PROTECTION**  
 SCALE: 1/2" = 1'-0"

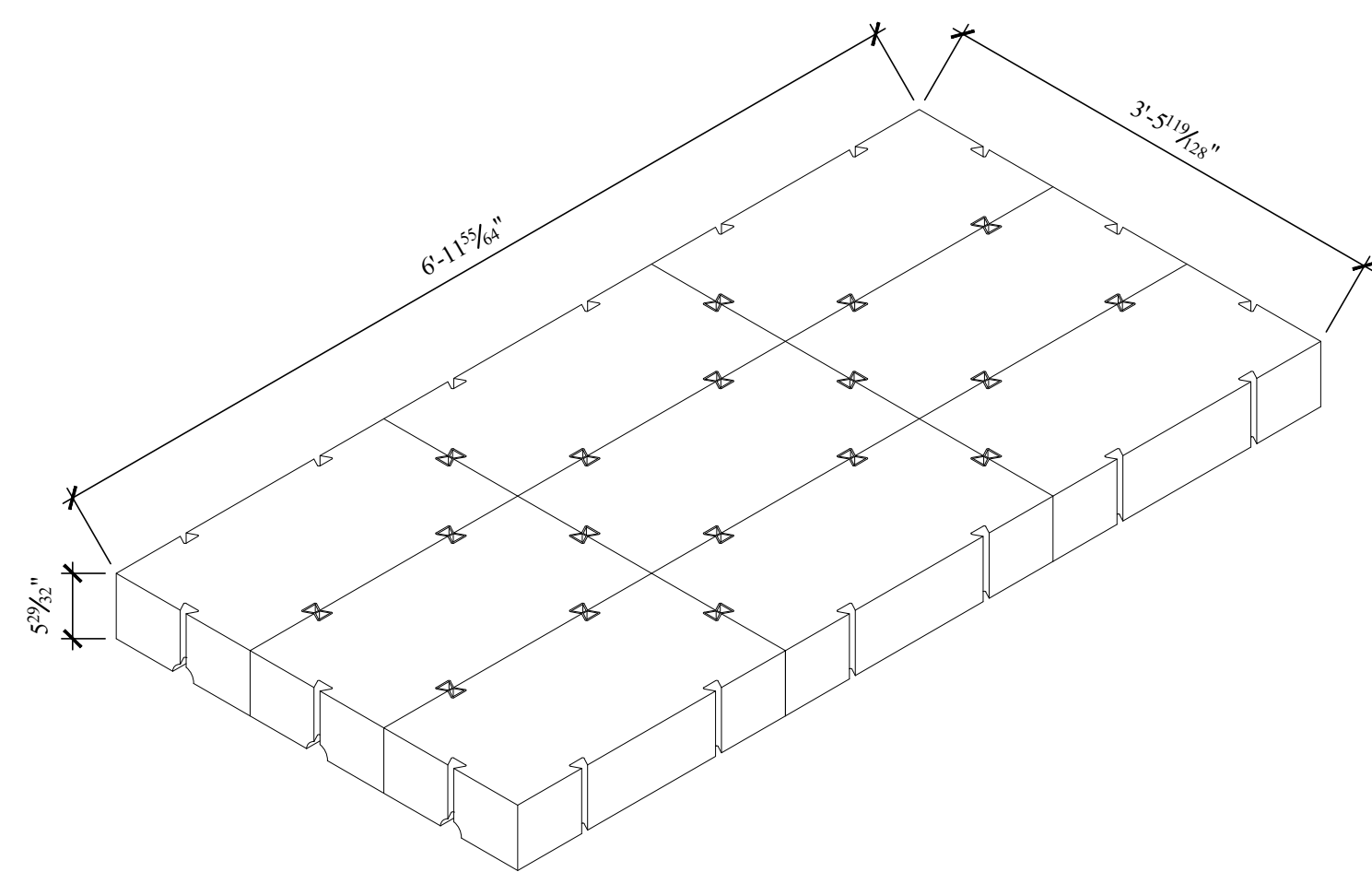

**ISOMETRIC**

| CH.# | A    |
|------|------|
| 1.08 | 4.3" |
| 1.10 | 5.1" |



**POLYDRAIN SHALLOW SECTION**  
 SCALE: 1-1/2" = 1'-0"

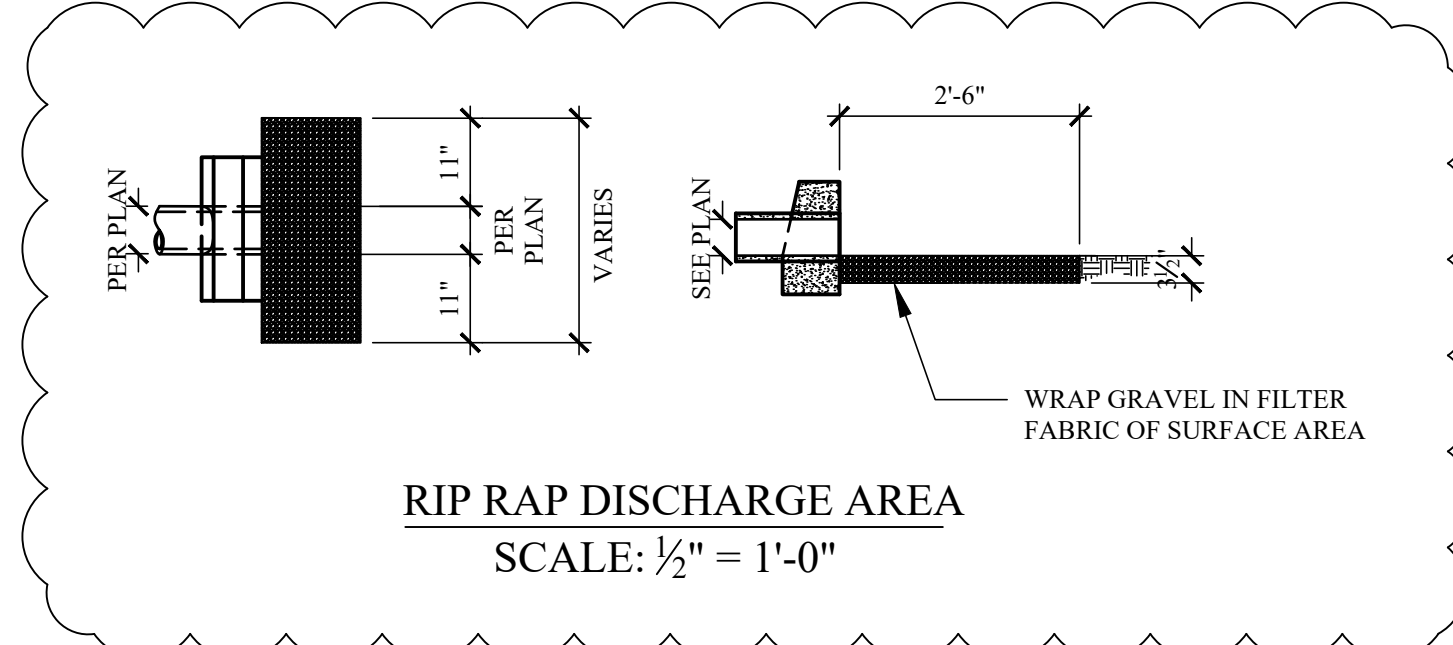

**RIP RAP DISCHARGE AREA**  
 SCALE: 1/2" = 1'-0"

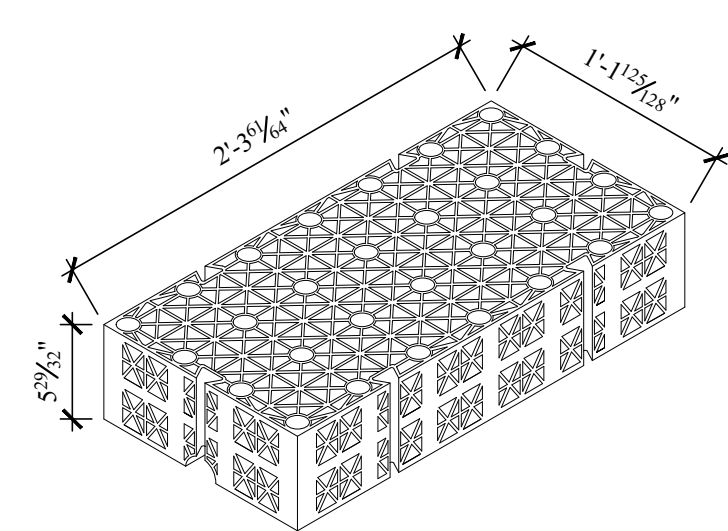

**ISOMETRIC**

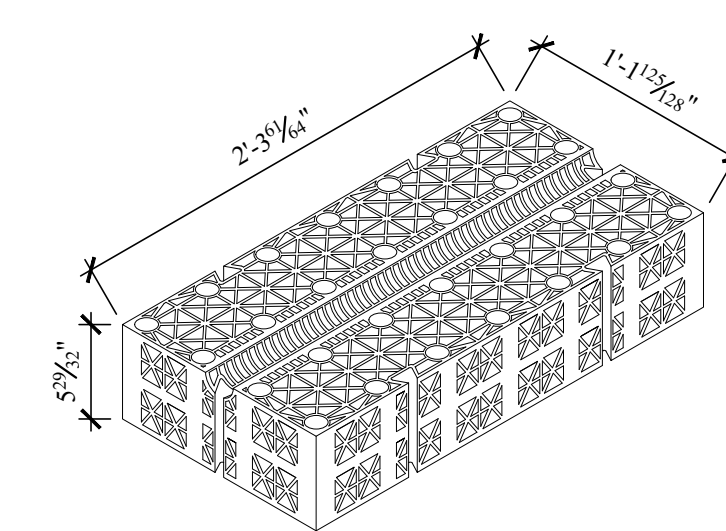

**ALT. ISOMETRIC**

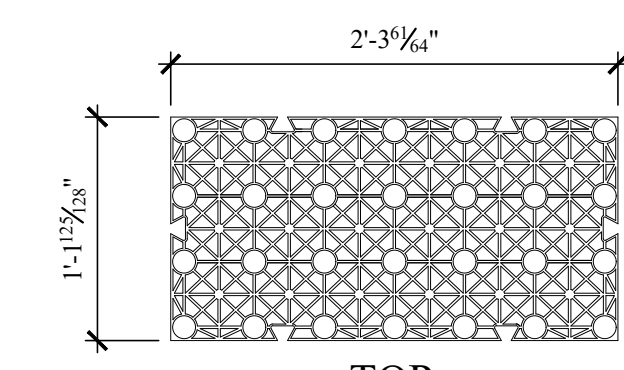

**TOP**

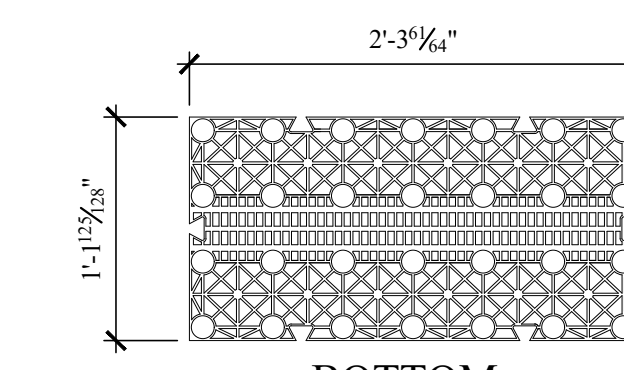

**BOTTOM**

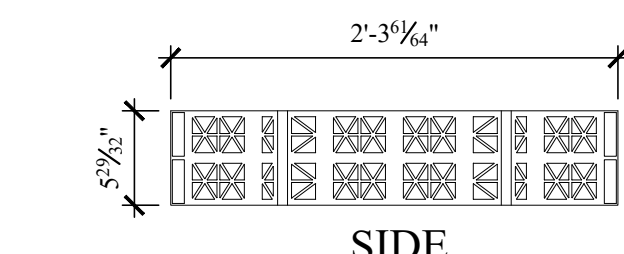

**SIDE**

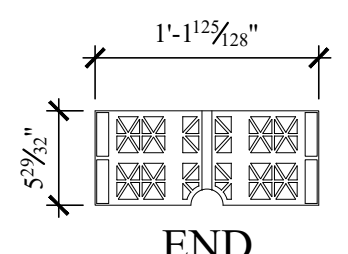

**END**

**PERMAVOID 150 UNIT**  
 SCALE: 1" = 1'-0"

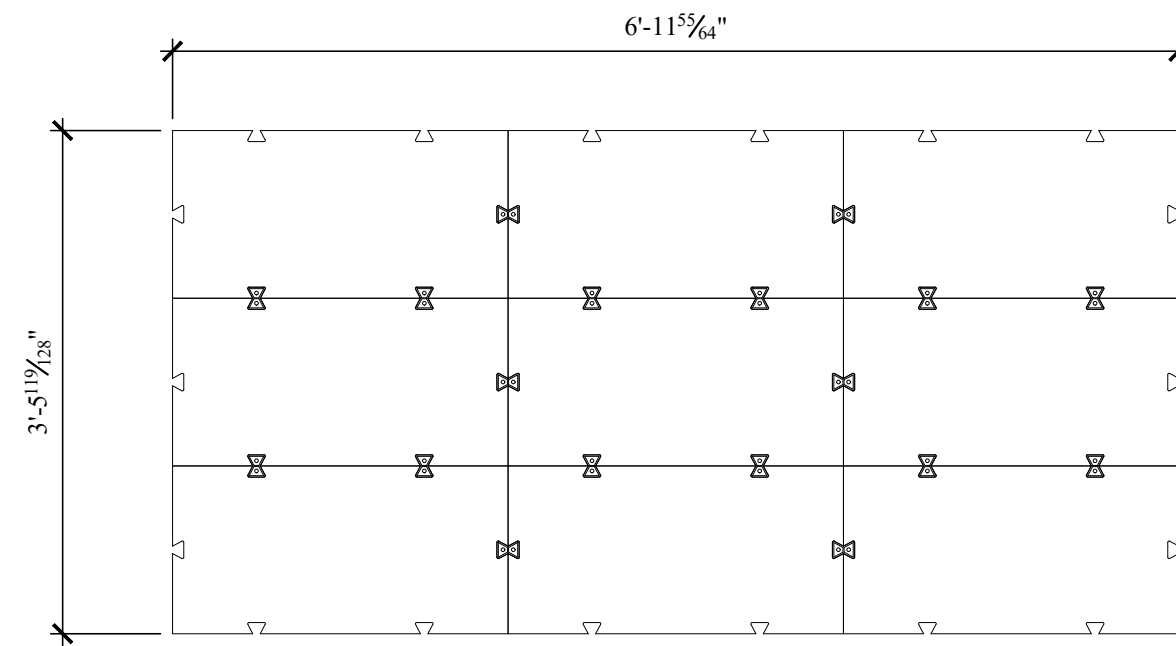

**TOP**

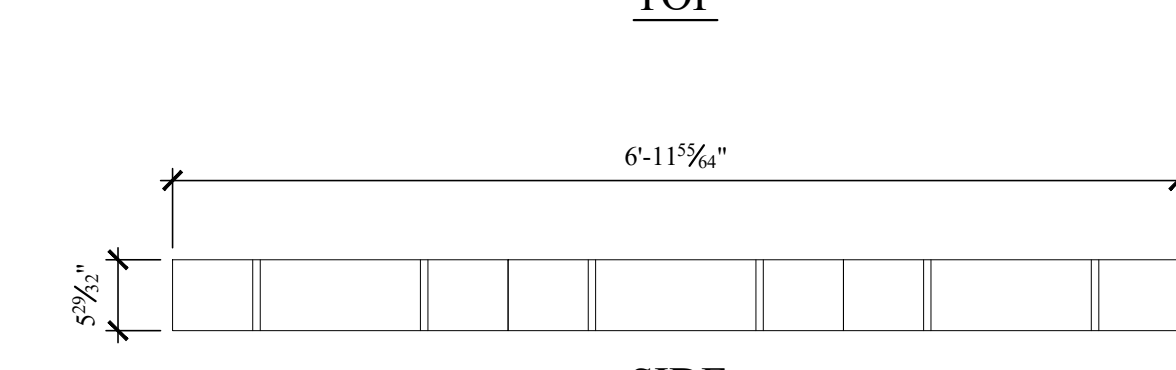

**SIDE**

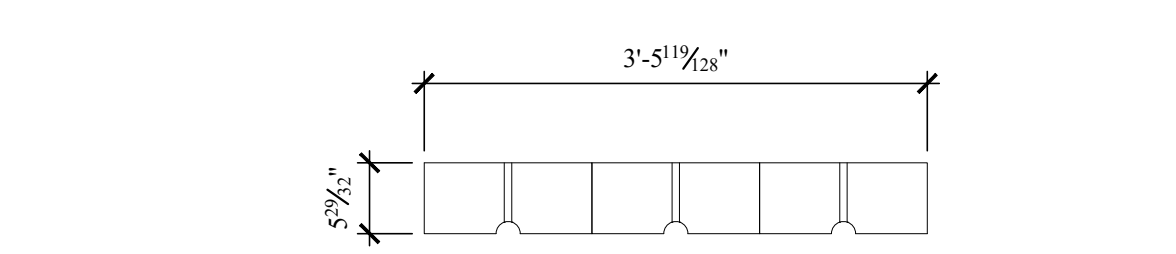

**END**

**PERMAVOID 150 PANELS**  
 SCALE: 3/4" = 1'-0"

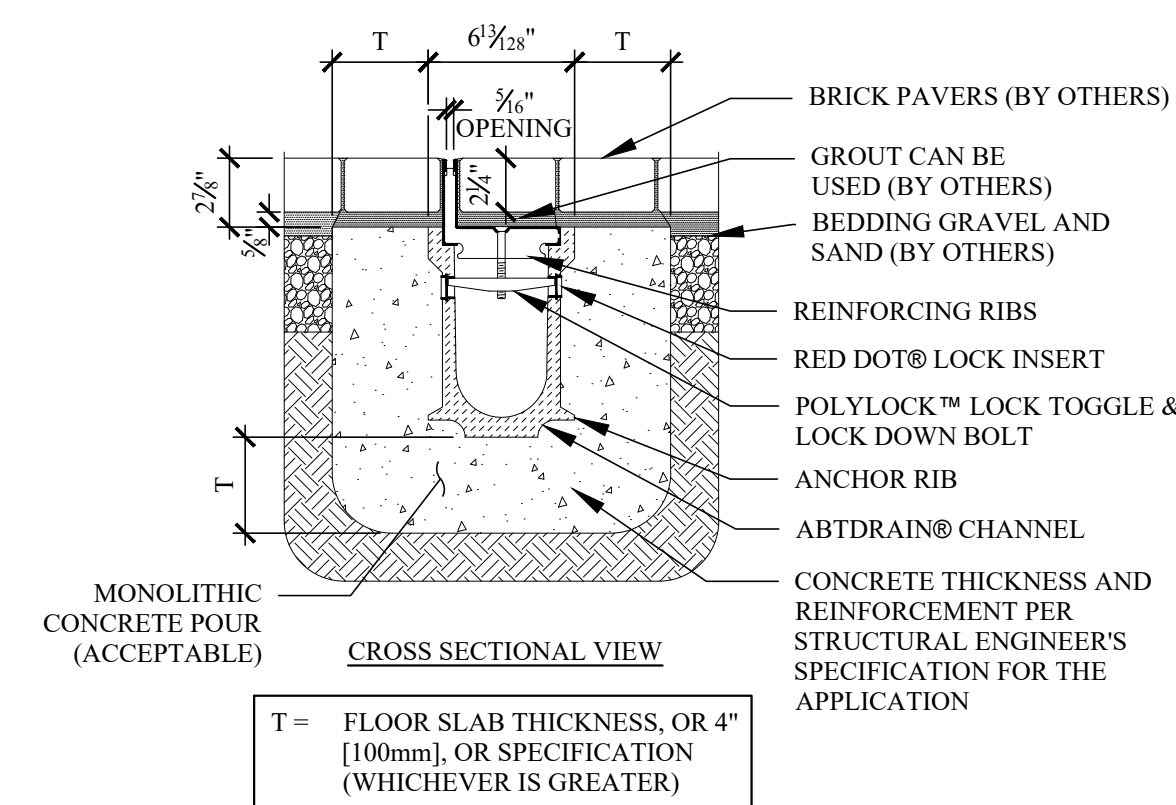

**CROSS SECTIONAL VIEW**

MONOLITHIC CONCRETE POUR (ACCEPTABLE)

T = FLOOR SLAB THICKNESS, OR 4" (100mm), OR SPECIFICATION (WHICHEVER IS GREATER)

**PD-2440PG - POLYDRAIN PAVER GRATE**  
 4" ID PRECASR TRENCH DRAIN WITH STAINLESS STEEL ADA & HEEL PROOF PAVER GRATE  
 SCALE: 1-1/2" = 1'-0"

**59 TWEED BLVD.**

| No. | REMARKS    | DATE       |
|-----|------------|------------|
| 1   | REVISION 1 | 02/02/2022 |
| 2   |            |            |
| 3   |            |            |

PROJECT:  
**RESIDENCE**  
 59 TWEED BOULEVARD  
 ORANGEBURG, NY 10960



STORMWATER  
 MANAGEMENT DETAILS  
 (1)

|              |            |
|--------------|------------|
| DATE:        | 02/02/2022 |
| PROJECT No.: | 21-077     |
| DRAWING BY:  | JB         |
| CHK BY:      | GF         |
| DWG No.:     |            |

**C-300.01**

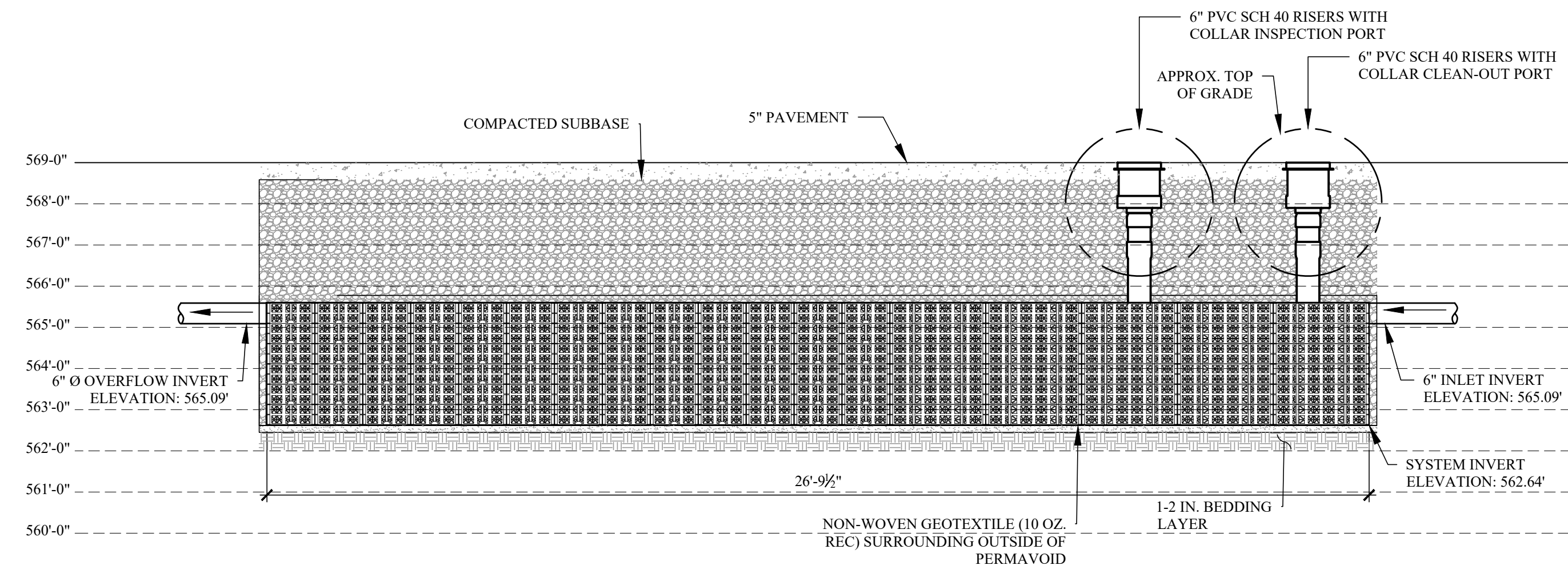

**A** PERMAVOID ZONE 1 ELEVATION  
C-110 SCALE: 3/8" = 1'-0"

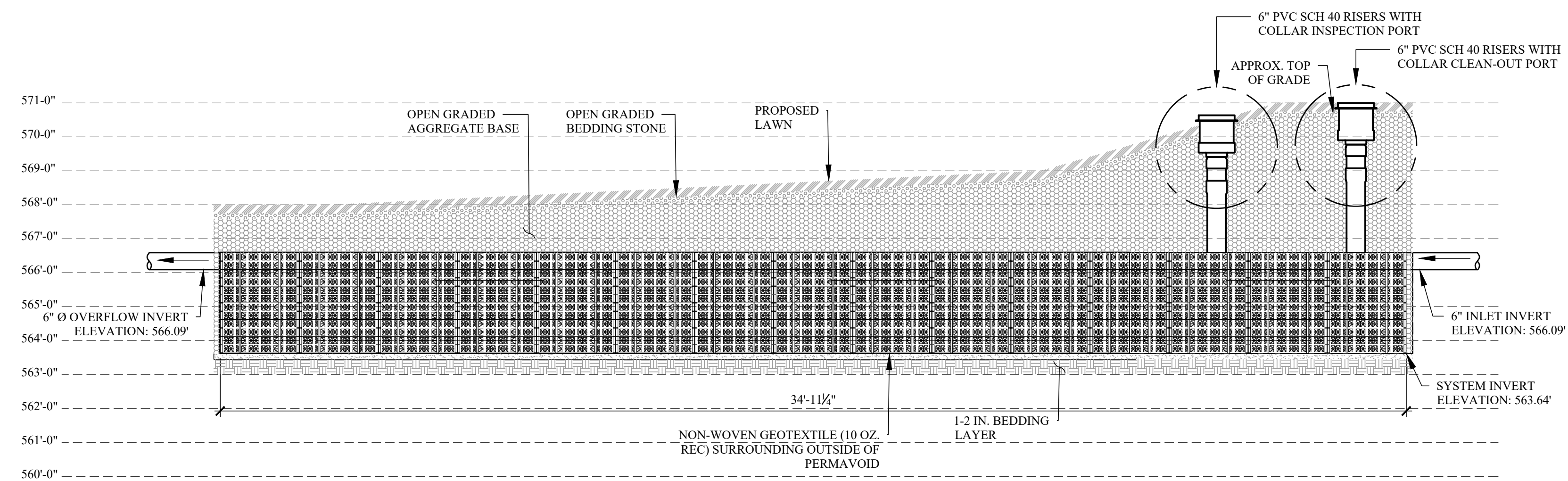

**B** PERMAVOID ZONE 2 ELEVATION  
C-110 SCALE: 3/8" = 1'-0"



**59 TWEED BLVD.**

| No. | REMARKS    | DATE       |
|-----|------------|------------|
| 1   | REVISION 1 | 02/02/2022 |
| 2   |            |            |
| 3   |            |            |
|     |            |            |
|     |            |            |
|     |            |            |
|     |            |            |
|     |            |            |

PROJECT:  
**RESIDENCE**  
59 TWEED BOULEVARD  
ORANGEBURG, NY 10960



STORMWATER  
MANAGEMENT DETAILS  
(2)

|              |            |
|--------------|------------|
| DATE:        | 02/02/2022 |
| PROJECT No.: | 21-077     |
| DRAWING BY:  | JB         |
| CHK BY:      | GF         |
| DWG No.:     |            |

**C-310.00**

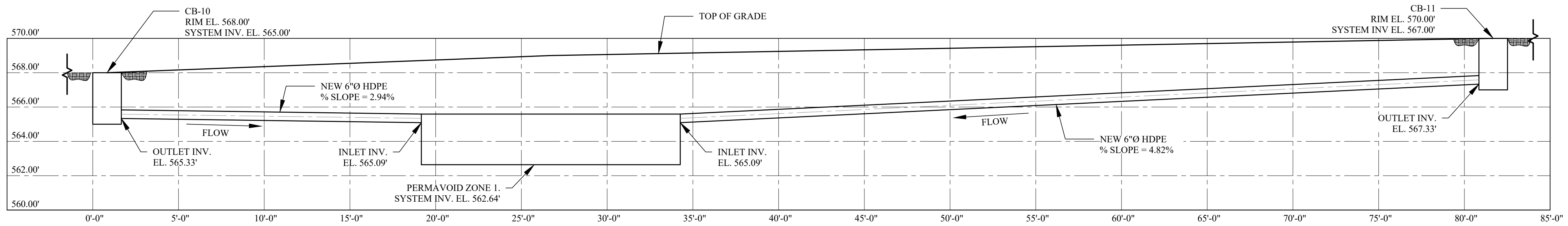

**A** STORMWATER PROFILE AT PERMAVOID ZONE 1  
 C-100 CB-10 AND CB-11  
 SCALE: 1/4"=1'-0"

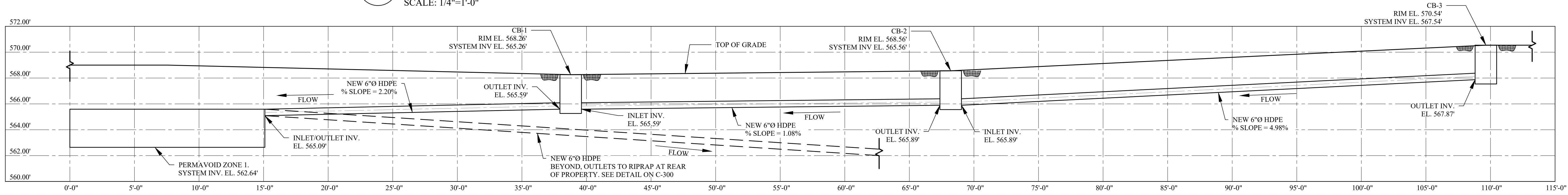

**B** STORMWATER PROFILE AT PERMAVOID ZONE 1  
 C-100 CB-1, CB-2, CB-3, AND PERMAVOID OUTLET  
 SCALE: 1/4"=1'-0"

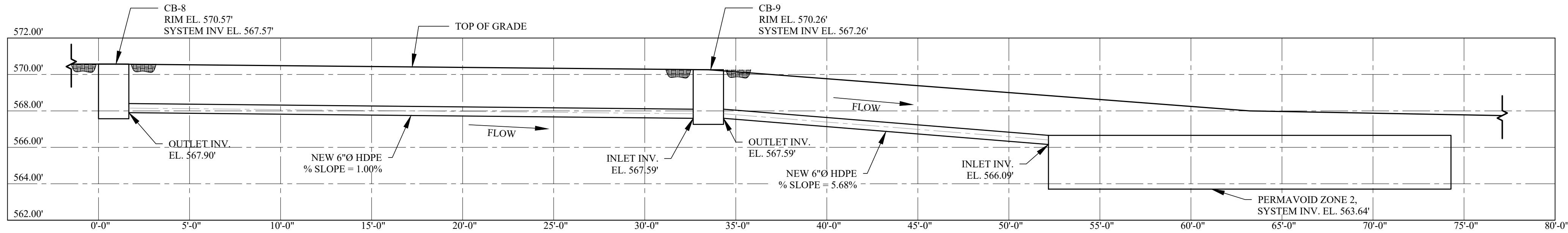

**C** STORMWATER PROFILE AT PERMAVOID ZONE 2  
 C-100 CB-8 AND CB-9  
 SCALE: 1/4"=1'-0"

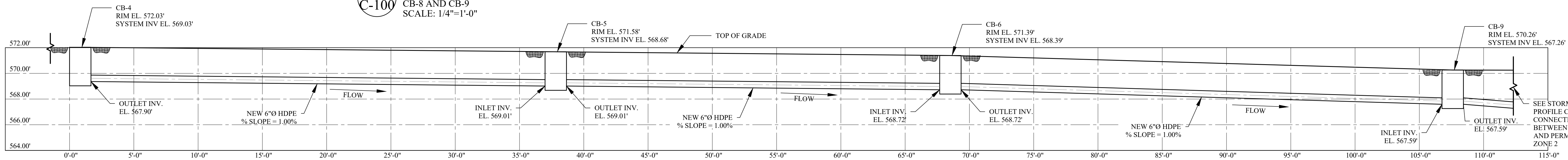

**D** STORMWATER PROFILE AT PERMAVOID ZONE 2  
 C-100 CB-4, CB-5, CB-6 AND CB-9  
 SCALE: 1/4"=1'-0"

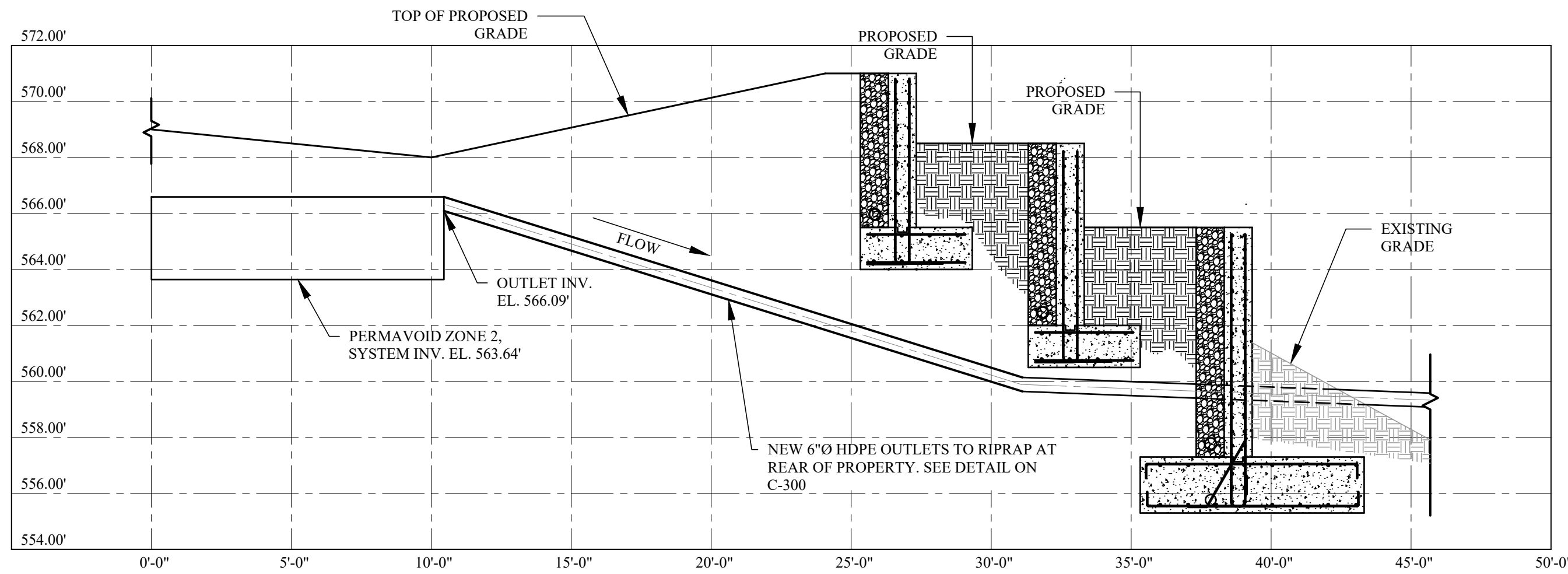

**E** STORMWATER PROFILE AT PERMAVOID ZONE 2  
 C-100 PERMAVOID OUTLET  
 SCALE: 1/4"=1'-0"

**59 TWEED BLVD.**

| No. | REMARKS    | DATE       |
|-----|------------|------------|
| 1   | REVISION 1 | 02/02/2022 |
| 2   |            |            |
| 3   |            |            |

PROJECT:  
**RESIDENCE**  
 59 TWEED BOULEVARD  
 ORANBURG, NY 10960



STORMWATER PROFILES

DATE: 02/02/2022  
 PROJECT No.: 21-077  
 DRAWING BY: JB  
 CHK BY: GF  
 DWG No.:

**C-320.00**

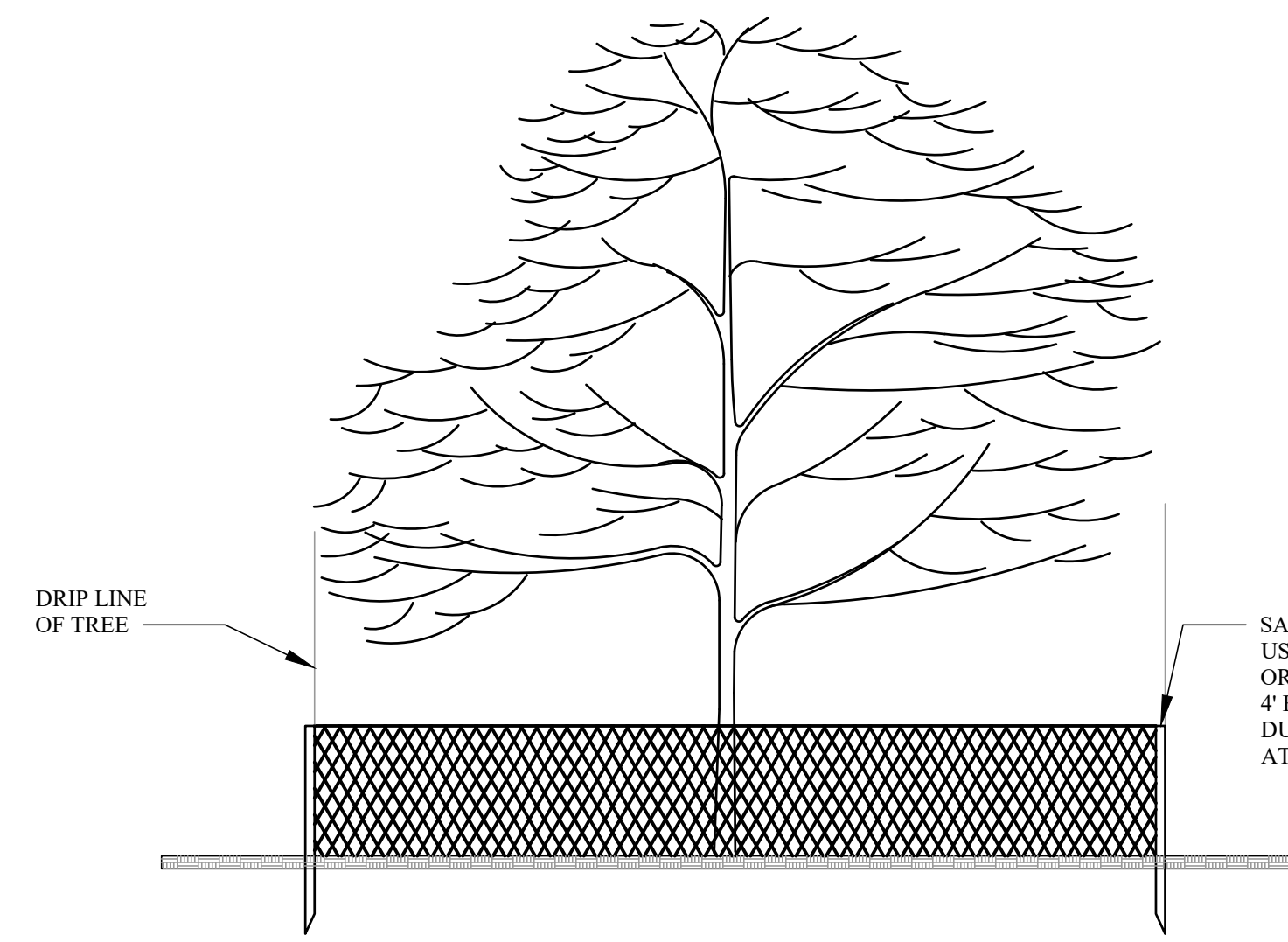

- 1- THE PROJECT DEVELOPER SHALL TAKE REASONABLE PRECAUTION TO SAVE SPECIMEN QUALITY TREES IN AREAS NOTED ON THE PLANS FOR CLEARING. WHEN POSSIBLE, THE DEVELOPER SHALL PROTECT INDIVIDUAL SPECIMEN TREES THROUGH THE INSTALLATION OF SAFETY FENCING AROUND THE DRIP LINE PERIMETER OF THE TREE.
- 2- SAFETY FENCING SHALL BE INSTALLED AT THE ONSET OF SITE CONSTRUCTION TO PREVENT VEHICLE TRAFFIC FROM COMPACTING THE SOILS IN THE VICINITY OF THE TREE ROOT STRUCTURE.

TREE PROTECTION DETAIL

**1** TREE PROTECTION DETAIL  
NOT TO SCALE

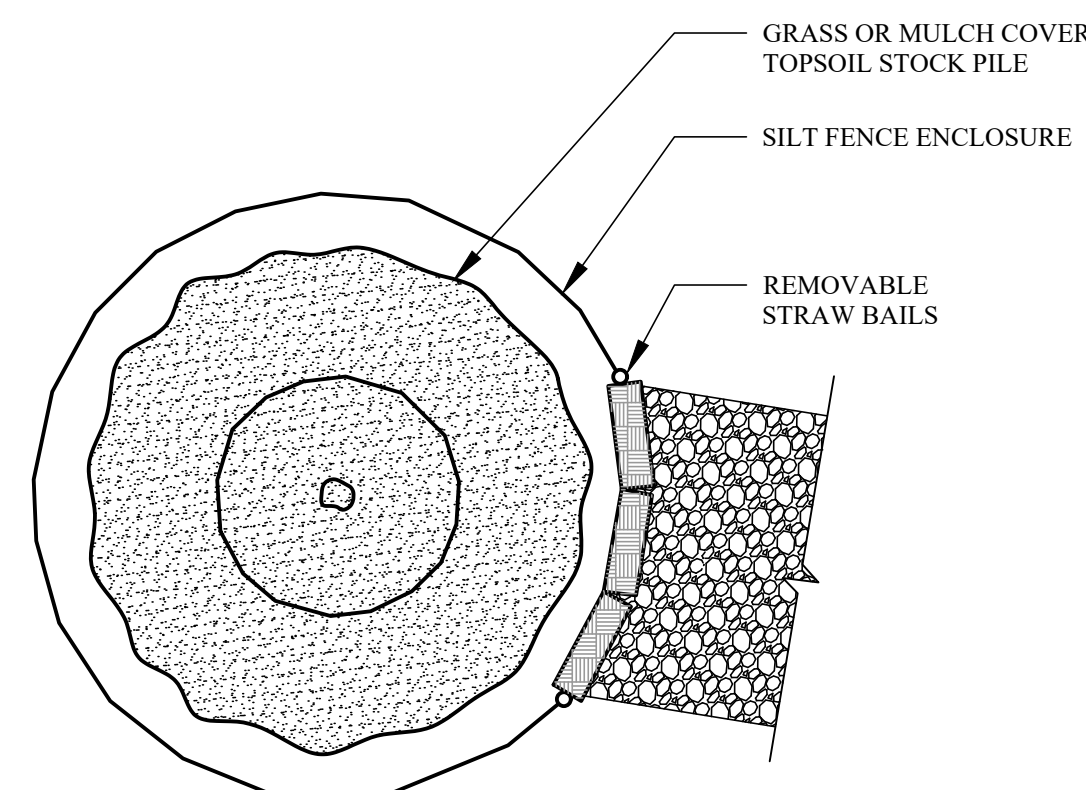

PLAN VIEW

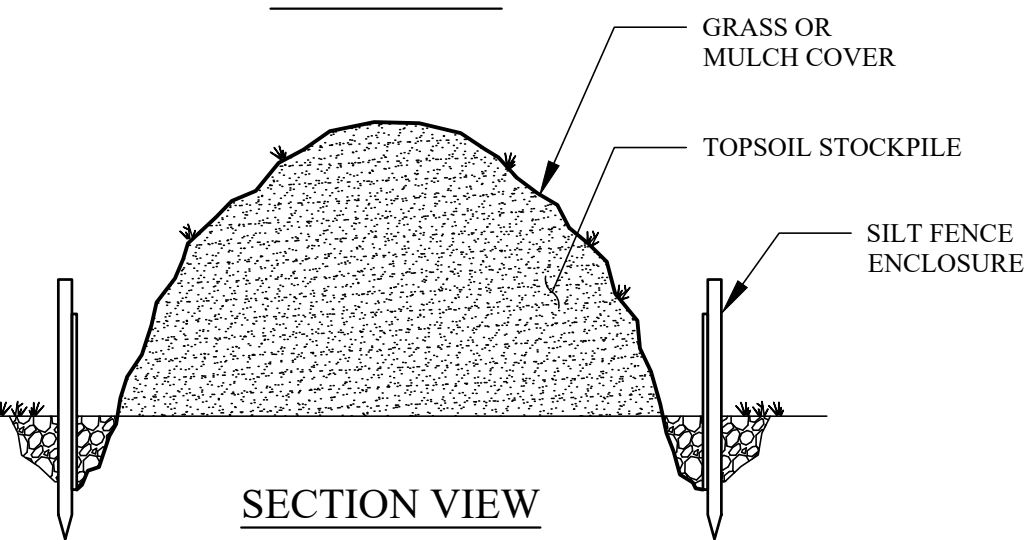

SECTION VIEW

NOTES:

1. SOIL STOCKPILE SHALL BE ENCIRCLED WITH SILT FENCING WITH PASSAGEWAY PROVIDED FOR EQUIPMENT ACCESS.
2. PROVIDE TEMPORARY GRASS OR MULCH COVER IF STOCKPILE IS TO REMAIN UNDISTURBED FOR THIRTY DAYS OR MORE. TEMPORARY COVER SHALL CONSIST OF ONE OF THE FOLLOWING MEASURES:
  - GRASS SEED: 1/2 LB. RYE GRASS /1000S.F
  - MULCH: 100LBS OF STRAW OR HAY/1000S.F

**3** SOIL STOCK PILE DETAIL  
NOT TO SCALE

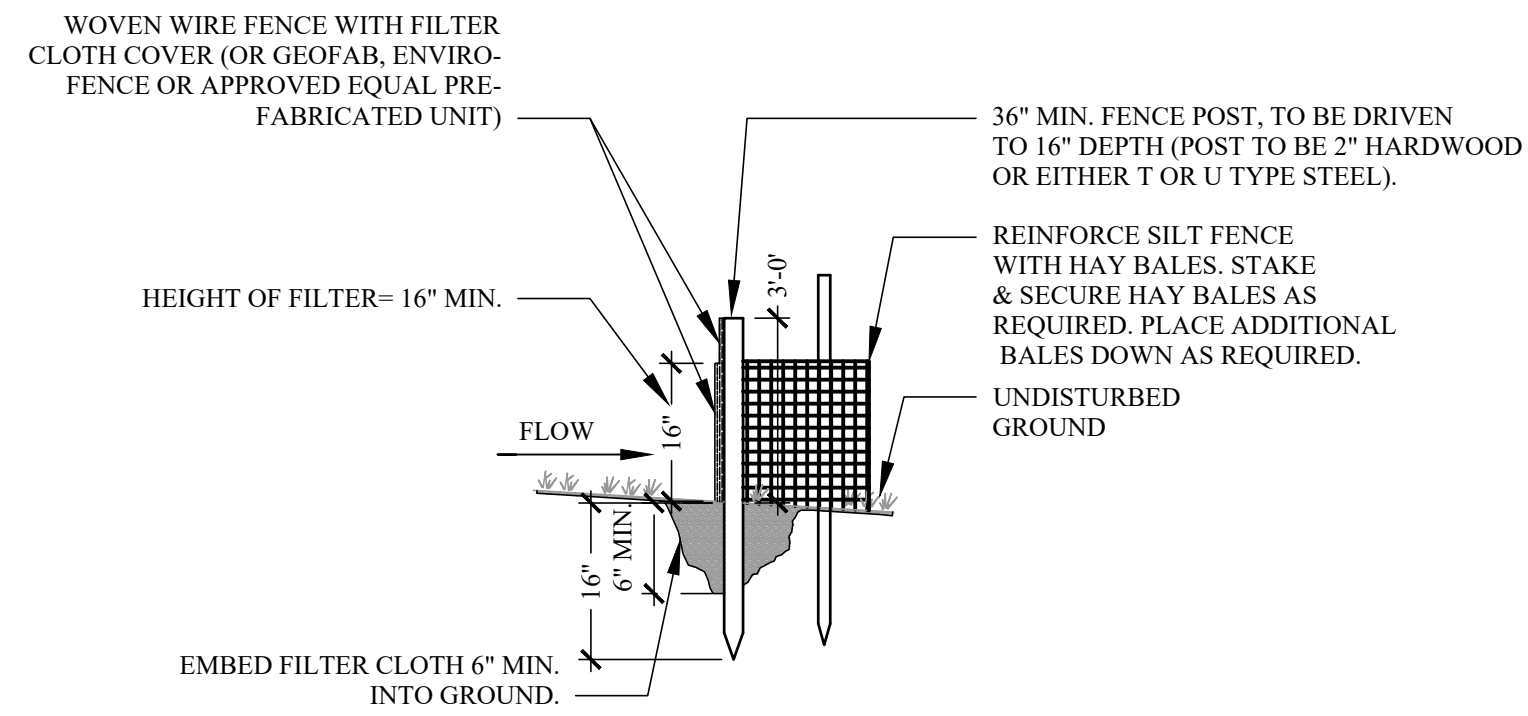

NOTES:

- 1- POST SPACING TO BE 10' MAX. O.C.
- 2- WOVEN WIRE FENCE TO BE FASTENED SECURELY TO FENCE POSTS WITH WIRE TIES OR STAPLES.
- 3- WOVEN WIRE FENCE TO BE 14 GA. MIN., 6" MAX. SPACING.
- 4- FILTER CLOTH TO BE FILTER X, MIRAFI 100XOR APPROVED EQUAL.
- 5- FILTER CLOTH TO BE FASTENED SECURELY TO WOVEN WIRE FENCE, WITH WIRE TIES SPACED EVERY 24" AT TOP AND MID SECTION.
- 6- WHEN TWO SECTIONS OF FILTER CLOTH ADJOIN EACH OTHER, THEY SHALL BE OVERLAPPED BY SIX INCHES, FOLDED AND STAPLED OR TIED TO A POST (PROVIDE POST AT SPLICE).
- 7- MAINTENANCE SHALL BE PERFORMED AS NEEDED, AND MATERIAL REMOVED WHEN BULGES DEVELOP IN THE SILT FENCE.
- 8- BALES SHALL BE PLACED AT THE TOE OF SLOPE OR ON THE CONTOUR AND IN A ROW WITH ENDS TIGHTLY ABUTTING THE ADJACENT BALES.
- 9- EACH BALE SHALL BE EMBEDDED IN THE SOIL A MINIMUM OF (4) INCHES, AND PLACED SO THE BINDINGS ARE HORIZONTAL.
- 10- BALES SHALL BE SECURELY ANCHORED IN PLACE BY EITHER TWO STAKES OR REBARS DRIVEN THROUGH THE BALE. THE FIRST STAKE IN EACH BALE SHALL BE DRIVEN TOWARD THE PREVIOUSLY LAID BALE AT AN ANGLE TO FORCE THE BALES TOGETHER. STAKES SHALL BE DRIVEN 1 1/2" TO 2" INTO THE GROUND AND FLUSH WITH THE BALE.
- 11- INSPECTION SHALL BE FREQUENT AND REPAIR REPLACEMENT SHALL BE MADE PROMPTLY AS NEEDED.
- 12- BALES SHALL BE REMOVED WHEN THEY HAVE SERVED THEIR USEFULNESS SO AS NOT TO BLOCK OR IMPEDE STORM FLOW OR DRAINAGE.

**2** TYPICAL SILT FENCE DETAIL  
NOT TO SCALE

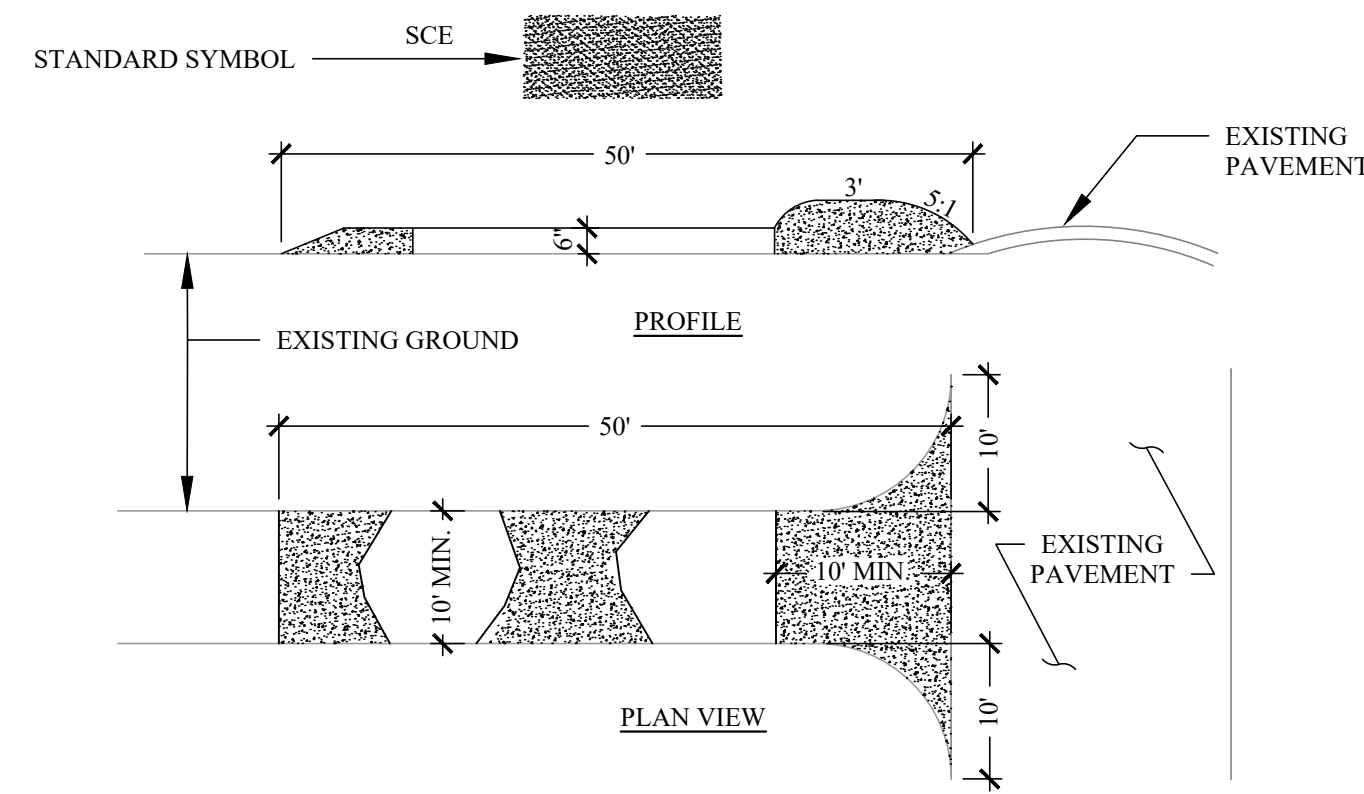

CONSTRUCTION SPECIFICATIONS:

- 1- STONE SIZE - USE 2" STONE OR RECLAIMED OR RECYCLED CONCRETE EQUIVALENT.
- 2- LENGTH - AS REQUIRED, BUT NOT LESS THAN 50 FEET (EXCEPT ON A SINGLE RESIDENCE LOT WHERE A 30 FOOT MINIMUM LENGTH WOULD APPLY).
- 3- THICKNESS - NOT LESS THAN (6) INCHES.
- 4- WIDTH - TEN (10) FOOT MINIMUM, BUT NOT LESS THAN THE FULL WIDTH AT POINTS WHERE INGRESS OR EGRESS OCCURS.
- 5- FILTER CLOTH - WILL BE PLACED OVER THE ENTIRE AREA PRIOR TO PLACING OF STONE. FILTER WILL NOT BE REQUIRED ON A SINGLE FAMILY RESIDENCE LOT.
- 6- SURFACE WATER - ALL SURFACE WATER FLOWING OR DIVERTED TOWARD CONSTRUCTION ENTRANCE SHALL BE PIPED ACROSS THE ENTRANCE. IF PIPING IS IMPRACTICAL, A MOUNTABLE BERM WITH 5:1 SLOPE WILL BE PERMITTED.
- 7- MAINTENANCE - THE ENTRANCE SHALL BE MAINTAINED IN A CONDITION WHICH WILL PREVENT TRACKING OR FLOWING OF SEDIMENT ONTO PUBLIC RIGHT-OF-WAYS. THIS MAY REQUIRE PERIODIC TOP DRESSING WITH ADDITIONAL STONE AS CONDITIONS DEMAND AND REPAIR AND/OR CLEANING OF ANY MEASURE USED TO TRAP SEDIMENT. ALL SEDIMENT SPILLED, DROPPED, WASHED OR TRACKED ONTO PUBLIC RIGHT-OF-WAYS MUST BE REMOVED IMMEDIATELY.
- 8- WASHING - WHEELS SHALL BE CLEANED TO REMOVE SEDIMENT PRIOR TO ENTRANCE ONTO PUBLIC RIGHT-OF-WAYS. WHEN WASHING IS REQUIRED, IT SHALL BE DONE ON AN AREA STABILIZED WITH STONE AND WHICH DRAINS INTO AN APPROVED SEDIMENT TRAPPING DEVICE.
- 9- PERIODIC INSPECTION AND NEEDED MAINTENANCE SHALL BE PROVIDED AFTER EACH RAIN.

**4** STABILIZED CONSTRUCTION ENTRANCE  
NOT TO SCALE

EROSION CONTROL:

1. ALL SOIL EROSION AND SEDIMENT CONTROL PRACTICES WILL BE INSTALLED IN ACCORDANCE WITH THE STANDARDS FOR SOIL EROSION AND SEDIMENT CONTROL IN STATE STANDARDS AND WILL BE INSTALLED IN PROPER SEQUENCE AND MAINTAINED UNTIL PERMANENT STABILIZATION IS ESTABLISHED.
2. ANY DISTURBED AREA THAT WILL BE LEFT EXPOSED FOR MORE THAN THIRTY (30) DAYS AND NOT SUBJECTED TO CONSTRUCTION TRAFFIC SHALL IMMEDIATELY RECEIVE TEMPORARY SEEDING AND MULCHING. IF THE SEASON PROHIBITS TEMPORARY SEEDING, THE DISTURBED AREA WILL BE MULCHED WITH SALT HAY OR EQUIVALENT AND BOUND IN ACCORDANCE WITH THE NY STANDARDS (I.E. PEG AND TWINE, MULCH NETTING, OR LIQUID MULCH BINDER).
3. IMMEDIATELY FOLLOWING INITIAL DISTURBANCE OR ROUGH GRADING, ALL CRITICAL AREAS SUBJECTED TO EROSION WILL RECEIVE A TEMPORARY SEEDING IN COMBINATION WITH STRAW MULCH OR SUITABLE EQUIVALENT, AT A RATE OF 2 TONS PER ACRE, ACCORDING TO NY STANDARDS.
4. STABILIZATION SPECIFICATIONS:
  - A. TEMPORARY SEEDING AND MULCHING:
    - LIME - 90 LBS./1,000 SF GROUND LIMESTONE; FERTILIZER - 11 LBS./1,000 SF, 10-20-10 OR EQUIVALENT WORKED INTO THE SOIL A MINIMUM OF 4".
    - SEED - PERENNIAL RYE GRASS 40 LBS./ACRE (1 LB / 1,000 SF) OR OTHER APPROVED SEEDS; PLANT BETWEEN MARCH 1 AND MAY 15 OR BETWEEN AUGUST 15 AND OCTOBER 1.
    - MULCH - SALT HAY OR SMALL GRAIN STRAW AT A RATE OF 70 TO 90 LBS./1,000 SF TO BE APPLIED ACCORDING TO THE NY STANDARDS. MULCH SHALL BE SECURED BY APPROVED METHODS (I.E. PEG AND TWINE, MULCH NETTING, OR LIQUID MULCH BINDER).
  - B. PERMANENT SEEDING AND MULCHING:
    - TOPSOIL - UNIFORM APPLICATION TO A DEPTH OF 5" (UNSETTLED).
    - LIME - 90 LBS./1,000 SF GROUND LIMESTONE; FERTILIZER - 11 LBS./1,000 SF, 10-20-10 OR EQUIVALENT WORKED INTO THE SOIL A MINIMUM OF 4".
    - SEED TURF TYPE TALL FESCUE (BLEND OF 3 CULTIVARS) 150 LBS./ACRE (3.5 LBS./1,000 SF) OR OTHER APPROVED SEED; PLANT BETWEEN MARCH 1 AND OCTOBER 15.
    - MULCH - SALT HAY OR SMALL GRAIN STRAW AT A RATE OF 70 TO 90 LBS./1,000 SF TO BE APPLIED ACCORDING TO THE NY STANDARDS. MULCH SHALL BE SECURED BY APPROVED METHODS (I.E. PEG AND TWINE, MULCH NETTING OR LIQUID BINDER).
5. THE SITE SHALL AT ALL TIMES BE GRADED AND MAINTAINED SUCH THAT ALL STORM WATER RUNOFF IS DIVERTED TO SOIL EROSION AND SEDIMENT CONTROL FACILITIES.
6. SOIL EROSION AND SEDIMENT CONTROL MEASURES WILL BE INSPECTED AND MAINTAINED ON A REGULAR BASIS, INCLUDING AFTER EVERY STORM EVENT.
7. STOCKPILES ARE NOT TO BE LOCATED WITHIN 50' OF A FLOOD PLAIN SLOPE, ROADWAY OR DRAINAGE FACILITY. THE BASE OF ALL STOCKPILES SHALL BE CONTAINED BY A STRAW BALE SEDIMENT BARRIER AND/OR SILT FENCE.
8. A CRUSHED STONE, VEHICLE WHEEL-CLEANING BLANKET WILL BE INSTALLED WHEREVER A CONSTRUCTION ACCESS ROAD INTERSECTS ANY PAVED ROADWAY. SAID BLANKET WILL BE COMPOSED OF 1" - 2" CRUSHED STONE, 6" THICK, WILL BE AT LEAST 30' X 100' AND SHOULD BE UNDERLAIN WITH A SUITABLE SYNTHETIC SEDIMENT FILTER FABRIC AND MAINTAINED.
9. MAXIMUM SIDE SLOPES OF ALL EXPOSED SURFACES SHALL NOT EXCEED 3:1 UNLESS OTHERWISE APPROVED BY THE ENGINEER.
10. DRIVEWAYS MUST BE STABILIZED WITH 1" - 2" CRUSHED STONE OR SUBBASE PRIOR TO INDIVIDUAL LOT CONSTRUCTION.
11. ALL SOIL WASHED, DROPPED, SPILLED OR TRACKED OUTSIDE THE LIMIT OF DISTURBANCE OR INTO PUBLIC RIGHT-OF-WAYS, WILL BE REMOVED IMMEDIATELY. PAVED ROADWAYS MUST BE KEPT CLEAN AT ALL TIMES.
12. CATCH BASIN INLETS WILL BE PROTECTED WITH AN INLET FILTER DESIGNED IN ACCORDANCE WITH NY STANDARDS.
13. STORM DRAINAGE OUTLETS WILL BE STABILIZED, AS REQUIRED, BEFORE THE DISCHARGE POINTS BECOME OPERATIONAL.
14. DEWATERING OPERATIONS MUST DISCHARGE DIRECTLY INTO A SEDIMENT CONTROL BAG OR OTHER APPROVED FILTER IN ACCORDANCE WITH NY STANDARDS.
15. DUST SHALL BE CONTROLLED VIA THE APPLICATION OF WATER, CALCIUM CHLORIDE OR OTHER APPROVED METHOD IN ACCORDANCE WITH NY STANDARDS.
16. TREES TO REMAIN AFTER CONSTRUCTION ARE TO BE PROTECTED WITH A SUITABLE FENCE INSTALLED AT THE DRIP LINE OR BEYOND IN ACCORDANCE WITH NY STANDARDS.
17. THE PROJECT OWNER SHALL BE RESPONSIBLE FOR ANY EROSION OR SEDIMENTATION THAT MAY OCCUR BELOW STORM WATER OUTFALLS OR OFF-SITE AS A RESULT OF CONSTRUCTION OF THE PROJECT.
18. ANY REVISION TO THE CERTIFIED SOIL EROSION AND SEDIMENT CONTROL PLAN MUST BE SUBMITTED TO THE ENGINEER FOR REVIEW AND APPROVAL PRIOR TO IMPLEMENTATION IN THE FIELD.
19. A COPY OF THE CERTIFIED SOIL EROSION AND SEDIMENT CONTROL PLAN MUST BE AVAILABLE AT THE PROJECT SITE THROUGHOUT CONSTRUCTION.
20. SILT FENCING SHALL BE ADJUSTED IN FIELD AND NOT ENCR OACH ONTO EXISTING TREES TO REMAIN AND SHALL ENCOMPASS LIMITS OF DISTURBANCE INCLUDING SEEPAGE PIT LOCATIONS.
21. THE TREE PROTECTION AND PRESERVATION WILL BE IMPLEMENTED IN ORDER TO PROTECT AND PRESERVE BOTH INDIVIDUAL SPECIMEN TREES AND BUFFER AREA WITH MANY TREES. STEPS THAT WILL BE TAKEN TO RESERVE AND PROTECT EXISTING TREES TO REMAIN ARE AS FOLLOWS:
  - A. NO CONSTRUCTION EQUIPMENT SHALL BE PARKED UNDER THE TREE CANOPY.
  - B. THERE WILL BE NO EXCAVATION OR STOCKPILING OF EARTH UNDERNEATH THE TREES.
  - C. TREES DESIGNATED TO BE PRESERVED SHALL BE MARKED CONSPICUOUSLY ON ALL SIDES AT A 5 TO 10 FOOT HEIGHT.
  - D. THE TREE PROTECTION ZONE FOR TREES DESIGNATED TO BE PRESERVED WILL BE ESTABLISHED BY ONE OF THE FOLLOWING METHODS:
    - ONE (1) FOOT RADIUS FROM TRUNK PER INCH DBH.
    - DRIP LINE OF THE TREE CANOPY.

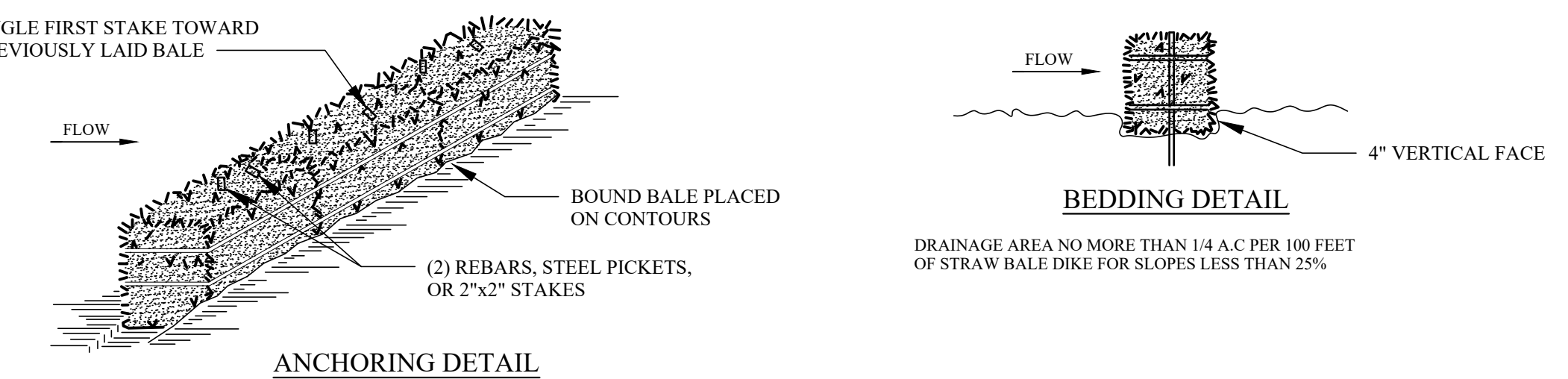

CONSTRUCTION SPECIFICATIONS:

- 1- BALES SHALL BE PLACED AT THE TOE OF SLOPE OR ON THE CONTOUR AND IN A ROW WITH ENDS TIGHTLY ABUTTING THE ADJACENT BALES.
- 2- EACH BALE SHALL BE EMBEDDED IN THE SOIL A MINIMUM OF (4) INCHES, AND PLACED SO THE BINDINGS ARE HORIZONTAL.
- 3- BALES SHALL BE SECURELY ANCHORED IN PLACE BY EITHER TWO STAKES OR REBARS DRIVEN THROUGH THE BALE. THE FIRST STAKE IN EACH BALE SHALL BE DRIVEN TOWARD THE PREVIOUSLY LAID BALE AT AN ANGLE TO FORCE THE BALES TOGETHER. STAKES SHALL BE DRIVEN 1 1/2" TO 2" INTO THE GROUND AND FLUSH WITH THE BALE.
- 4- INSPECTION SHALL BE FREQUENT AND REPAIR REPLACEMENT SHALL BE MADE PROMPTLY AS NEEDED.
- 5- BALES SHALL BE REMOVED WHEN THEY HAVE SERVED THEIR USEFULNESS SO AS NOT TO BLOCK OR IMPEDE STORM FLOW OR DRAINAGE.

**5** TYPICAL HAY BALE DETAIL  
NOT TO SCALE

| No. | REMARKS    | DATE       |
|-----|------------|------------|
| 1   | REVISION 1 | 02/02/2022 |
| 2   |            |            |
| 3   |            |            |

PROJECT:  
**RESIDENCE**  
59 TWEED BOULEVARD  
ORANGEBURG, NY 10960

SEAL & SIGNATURE:

SOIL EROSION AND SEDIMENT CONTROL DETAILS

DATE: 02/02/2022  
PROJECT No.: 21-077  
DRAWING BY: JB  
CHK BY: GF  
DWG No.:

C-400.00