

Name of Municipality: TOWN OF ORANGETOWN

Date Submitted: \_\_\_\_\_

2021 LAND USE BOARD APPLICATION

*Please check all that apply.*

<input type="checkbox"/> Commercial	<input checked="" type="checkbox"/> Residential
<input type="checkbox"/> Planning Board	<input type="checkbox"/> Historical Board
<input type="checkbox"/> Zoning Board of Appeals	<input type="checkbox"/> Architectural Board
<input type="checkbox"/> Subdivision	<input type="checkbox"/> Consultation
<input type="checkbox"/> Number of Lots	<input type="checkbox"/> Pre-Preliminary/Sketch
<input type="checkbox"/> Site Plan	<input type="checkbox"/> Preliminary
<input type="checkbox"/> Conditional Use	<input type="checkbox"/> Final
<input type="checkbox"/> Special Permit	<input type="checkbox"/> Interpretation
<input type="checkbox"/> Variance	
<input type="checkbox"/> Performance Standards Review	
<input type="checkbox"/> Use Variance	
<input type="checkbox"/> Other (specify): _____	

**PERMIT#:** 9LDG-83-2021  
**ASSIGNED**  
**INSPECTOR:** Glenn

Referred from Planning Board: YES / NO  
 If yes provide date of Planning Board meeting: \_\_\_\_\_

Project Name: REAR DECK REPLACEMENT; Identical Location + Size

Street Address: 175 Rutgers Road East  
Orangeburg, NY 10962

Tax Map Designation:

Section: 74.13 Block: 2 Lot(s): 62  
Section: \_\_\_\_\_ Block: \_\_\_\_\_ Lot(s): \_\_\_\_\_

Directional Location:

On the South (rear) side of 175 Rutgers Rd E., approximately \_\_\_\_\_ feet \_\_\_\_\_ of the intersection of \_\_\_\_\_, in the Town of ORANGETOWN in the hamlet/village of \_\_\_\_\_.

Acreage of Parcel \_\_\_\_\_  
School District \_\_\_\_\_  
Ambulance District \_\_\_\_\_  
Water District \_\_\_\_\_

Zoning District R-22  
Postal District \_\_\_\_\_  
Fire District \_\_\_\_\_  
Sewer District \_\_\_\_\_

Project Description: (If additional space required, please attach a narrative summary.)

land built by developer  
Replacement of rear deck; originally approved + directed by Town building dept. inspector before we took title and moved in in 1975; damaged by falling tree from Town parkland during hurricane in August 2020; same dimensions + location as original

The undersigned agrees to an extension of the statutory time limit for scheduling a public hearing.

Date: 12-9-21

Applicant's Signature: [Signature]

# APPLICATION REVIEW FORM

## FILL IN WHERE APPLICABLE.

( IF THE FOLLOWING DOES NOT APPLY PLEASE MOVE ON TO THE NEXT PAGE )

### If subdivision:

- 1) Is any variance from the subdivision regulations required? \_\_\_\_\_
- 2) Is any open space being offered? \_\_\_\_ If so, what amount? \_\_\_\_\_
- 3) Is this a standard or average density subdivision? \_\_\_\_\_

### If site plan:

- 1) Existing square footage \_\_\_\_\_
- 2) Total square footage \_\_\_\_\_
- 3) Number of dwelling units \_\_\_\_\_

If **special permit**, list special permit use and what the property will be used for.

---

---

### Environmental Constraints:

Are there **slopes greater than 25%**? If yes, please indicate the amount and show the gross and net area \_\_\_\_\_

Are there **streams** on the site? If yes, please provide the names. \_\_\_\_\_

Are there **wetlands** on the site? If yes, please provide the names and type:

---

### Project History:

Has this project ever been reviewed before? no \_\_\_\_\_

If so, provide a narrative, including the list case number, name, date, and the board(s) you appeared before, and the status of any previous approvals.

---

---

List tax map section, block & lot numbers for all other abutting properties in the same ownership as this project.

---

---



OFFICE OF BUILDING, ZONING, PLANNING,  
ADMINISTRATION AND ENFORCEMENT  
**TOWN OF ORANGETOWN**  
20 Greenbush Road  
Orangeburg, N.Y. 10962

Jane Slavin, R.A.  
Director

(845)359-8410

Fax: (845) 359-8526

**DENIAL TO THE ZONING BOARD OF APPEALS**

Date: November 18, 2021

Applicant: Leader

Address: 175 Rutgers Rd. Orangeburg, NY

RE: Application Made at: same

Chapter 43, Table 3.12, Column 1 R-15 District, Column 2 Group M, Column 3 SFR, Column 11 Rear  
Yard 35' w/ 28.8' proposed.  
One variances required

Section: 74.13

Block: 2

Lot: 62

Dear Leader:

Please be advised that the Building Permit Application, which you submitted on  
November 4, 2021, has been denied. I have enclosed a Xerox copy of your application, where you will find  
at the bottom the reason for denial.

In Accordance with Zoning, Chapter 43 Section 10.322 the time to appeal a determination of a  
Building Inspector or Similar administrative office is thirty (30) days from the filing of such a  
determination with the Town Clerk.

The Clerk to the Zoning Board of Appeals, Debbie Arbolino, will assist you in the preparation necessary to  
appear before the board.

Sincerely,

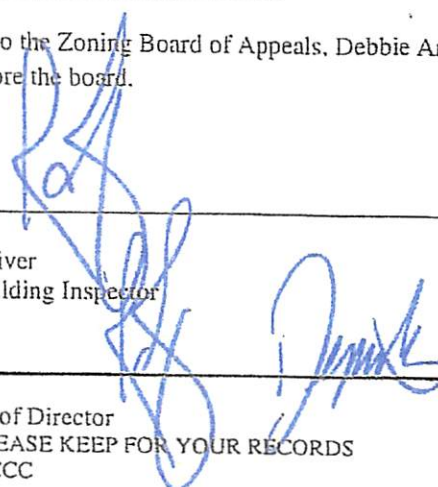
  
Richard Oliver  
Deputy Building Inspector

Signature of Director  
NOTE: PLEASE KEEP FOR YOUR RECORDS  
12-31-18-CCC

11.18.21  
Date  
CC: Rosanna Sfraga  
Liz Decort  
Debbie Arbolino

SWIS	PRINT KEY	NAME	ADDRESS
392489	74.13-1-73	Karen Recca	35 Dutchess Dr,Orangeburg, NY 10962
392489	74.13-1-74	Mansoo Jo	33 Dutchess Dr,Orangeburg, NY 10962
392489	74.13-2-5	Salvatore J Cioffi	179 Rutgers Rd E,Orangeburg, NY 10962
392489	74.13-2-6	Diane Nasuta-Todd	178 Rutgers Rd E,Orangeburg, NY 10962
392489	74.13-2-7	Park Sung Soo	3 Augusta Ct,New City, NY 10956
392489	74.13-2-8	Vinod Yaragudri	176 E Rutgers Rd,Orangeburg, NY 10962
392489	74.13-2-9	Town Of Orangetown	26 Orangeburg Rd,Orangeburg, NY 10962
392489	74.13-2-45	Matthew Lavaia	43 Minute Man Cir,Orangeburg, NY 10962
392489	74.13-2-46	Richard V Hofmann	44 Minute Man Cir,Orangeburg, NY 10962
392489	74.13-2-60	Ferdinand A Monteleone	6 Goswick Ct,Sparkill, NY 10976
392489	74.13-2-61	Samantha A James	174 E Rutgers Rd,Orangeburg, NY 10962
392489	74.13-2-62	Maxine L Leader	175 E Rutgers Rd,Orangeburg, NY 10962

Add:

74.13-2-4 - 180 Rutgers Rd E Pearl River  
 74.13-1-72 - 37 Dutchess Dr Pearl River  
 74.13-2-44 - 42 Minute Man Cir PR  
 74.13-2-47 - 45 Minute Man Cir PR

SURVEY  
PROPERTY

MAXINE LEADER  
175 Rutgers Rd E  
Orangetown, NY 10962

AT  
NAURAUSAUN

TOWN OF ORANGETOWN

ROCKLAND COUNTY

NEW YORK

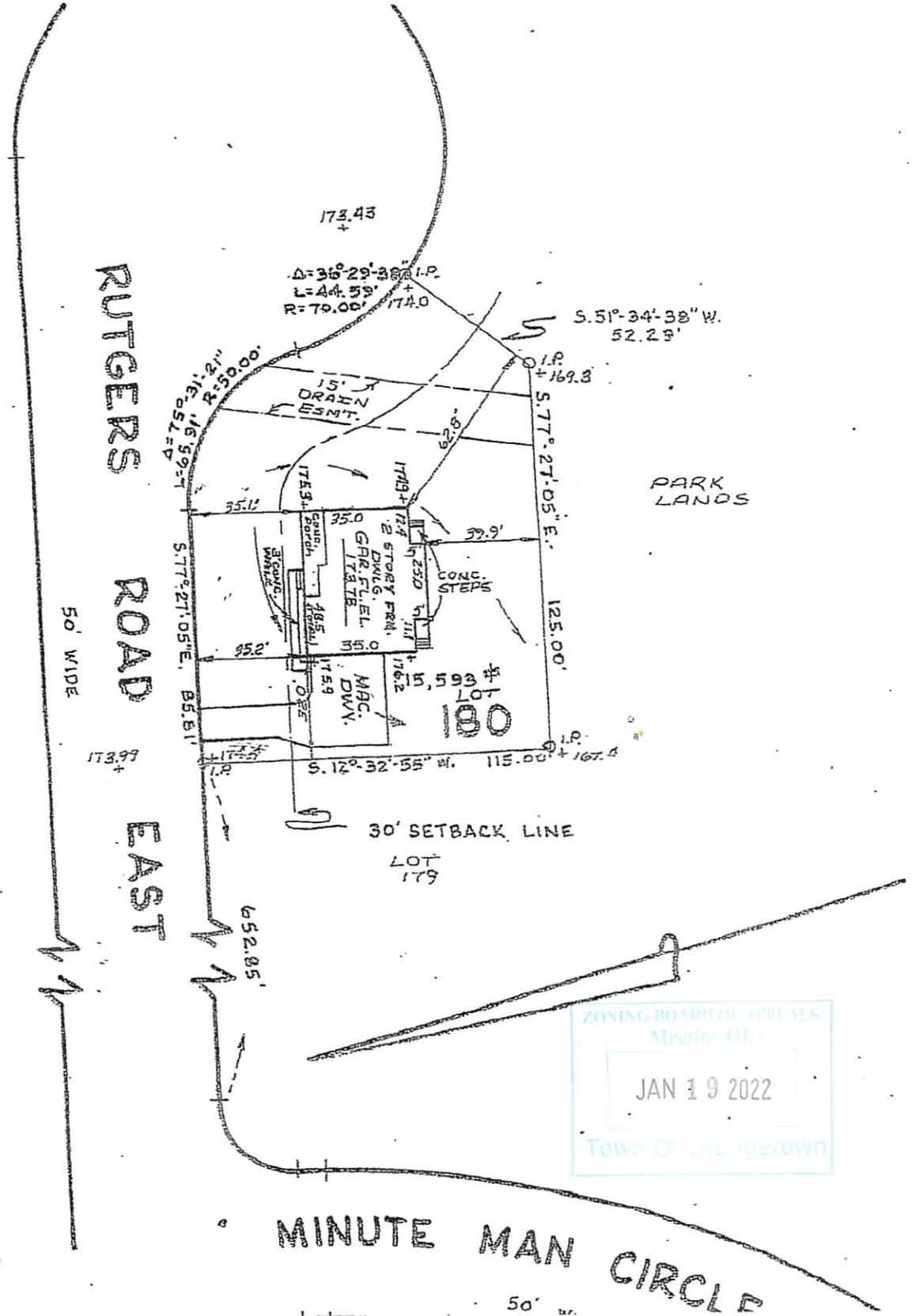

PARK LANDS

ZONING BOARD OF APPEALS  
Meeting Of:  
JAN 19 2022  
Town Of Orangetown

1975  
LEADER

MINUTE MAN  
CIRCLE

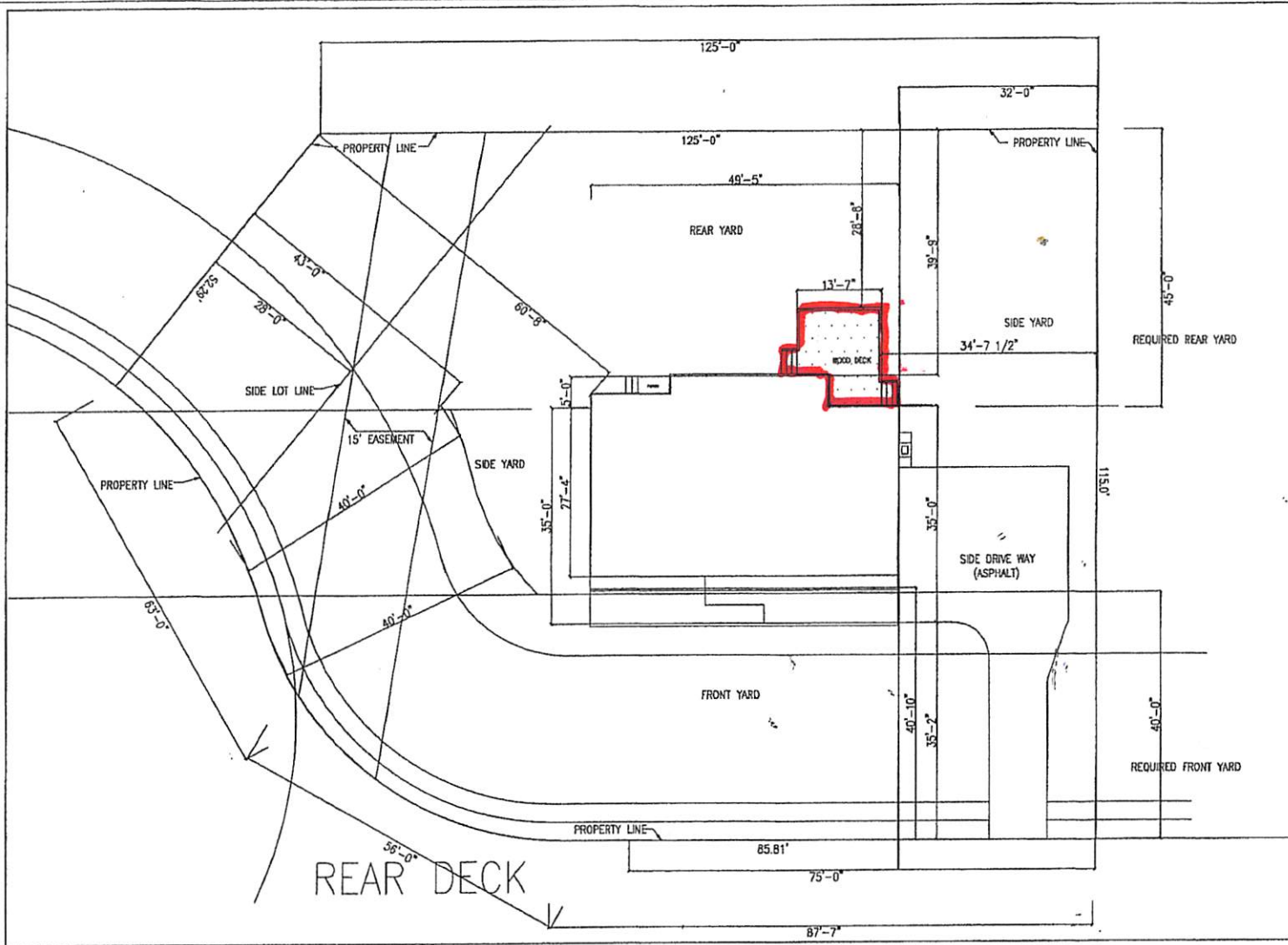

ZONING BOARD OF APPEALS  
 Meeting Of  
 JAN 19 2022  
 Town



2021 LEADERS

175 EAST RUTGERS ROAD

14' X 16' REAR DECK

DATE 10-20-2021

DRAWING TITLE A-1

ARCHITECT'S SEAL & SIGN

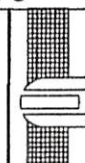

Office (212) 370-9791  
 Cell (646) 210-6932  
 eml.eshkar@hotmail.com  
**ORLI ESHKAR**  
 ARCHITECT, PLLC  
 111 Tweed Blvd, Nyack NY 10960



ZONING BOARD OF APPEALS  
 Meeting Of  
**JAN 19 2022**  
 Town Of Orangetown

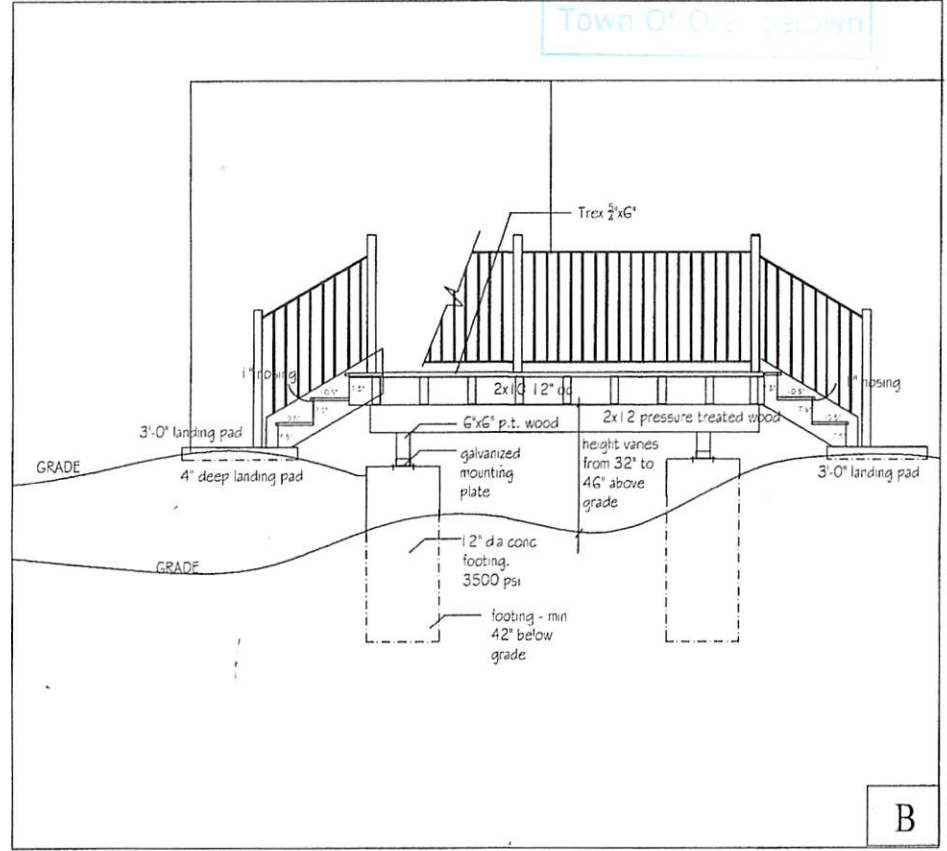
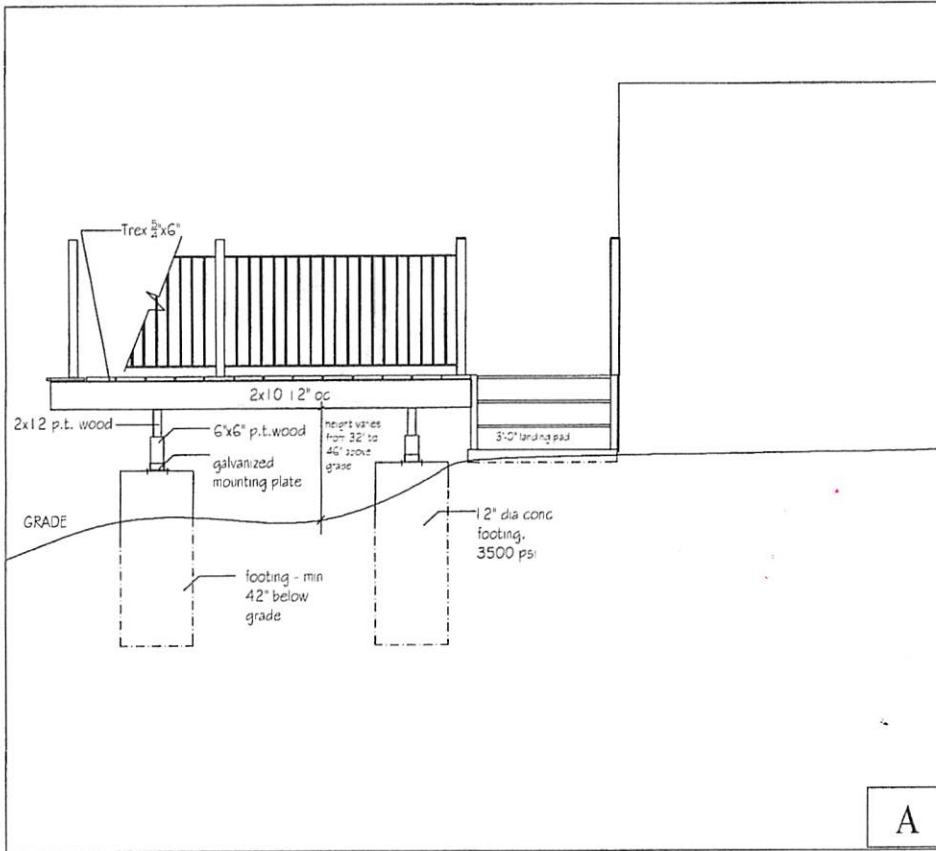

175 EAST RUTGERS ROAD  
 14' X16' REAR DECK

*LEADER*  
*1 of 3*

ARCHITECTS SEAL & SIGN  
 DATE: 10-20-2021  
 DRAWING TITLE: A-4



Office (212) 370-4791  
 Cell (646) 210-6932  
 eml.eshkar@hotmail.com  
**ORLI ESHKAR**  
 ARCHITECT, PLLC  
 121 Tweed Blvd, Nyack NY 10960





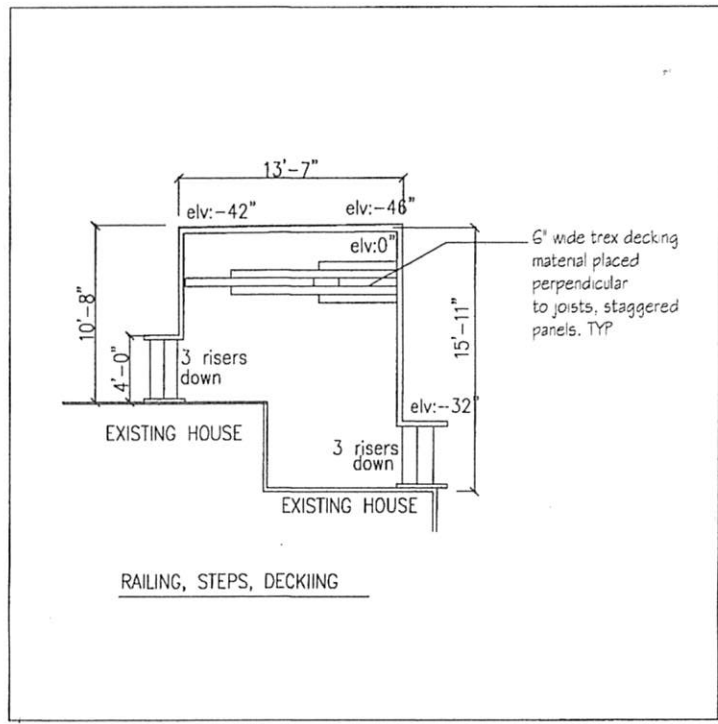
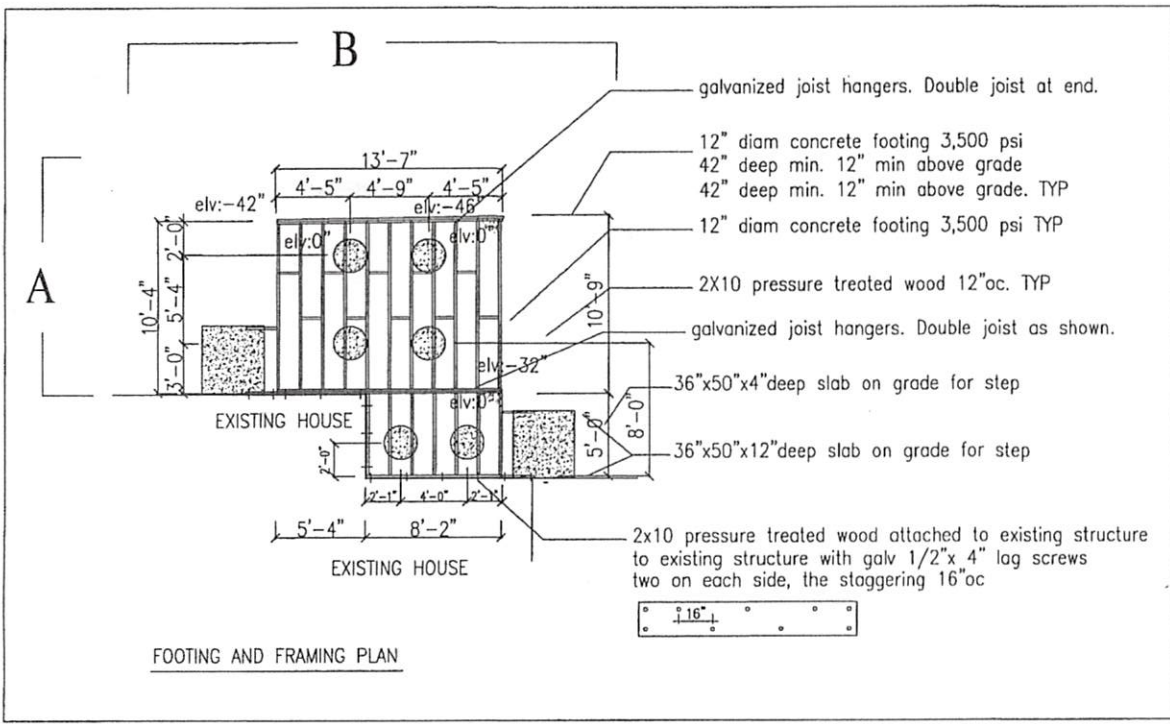

ZONING DEPARTMENT  
 JAN 19 2022  
 Town Of Orangetown

175 EAST RUTGERS ROAD  14' X 16' REAR DECK	LEADER 3 of 3	DATE: 10-20-2021 DRAWING TITLE: A-3	ARCHITECTS & SON	<p>             OffEce (212) 370-9791              Cell (646) 210-6932              eml orlleshkar@hotmail.com  <b>ORLI ESHKAR</b>              ARCHITECT, PLLC              121 Tweed Blvd, Nyack NY 10960           </p>
--	------------------	--	------------------	--