











**CURB RAMP DETAILS**

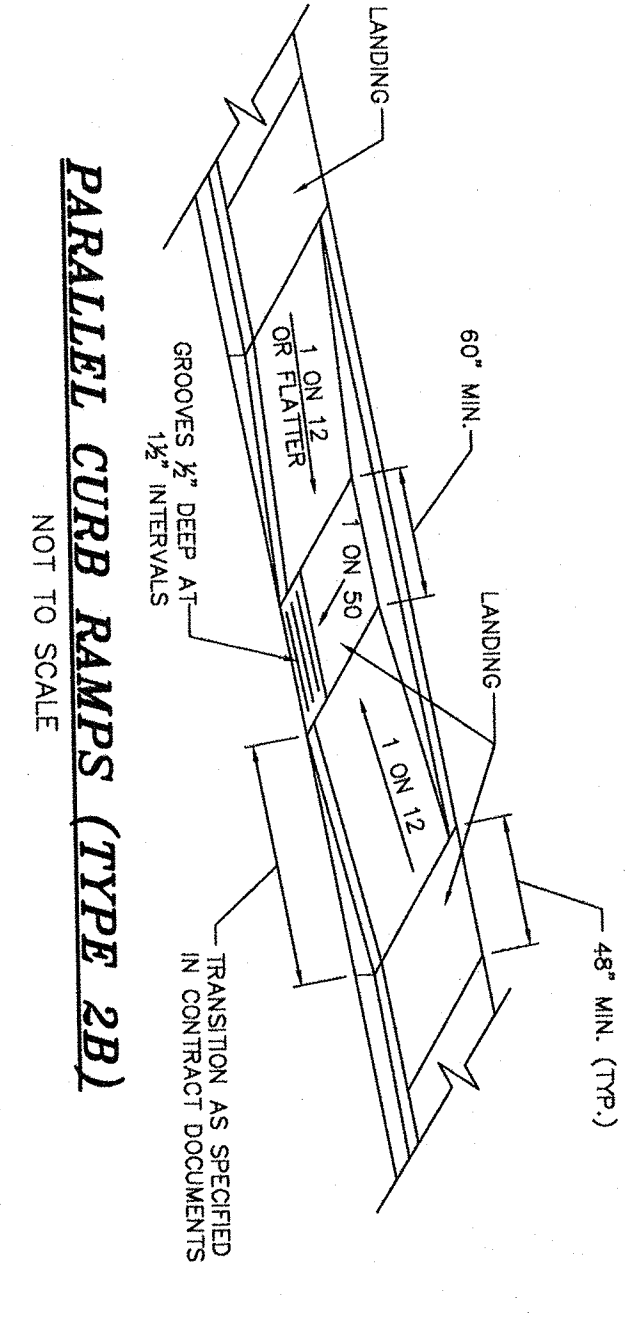

**PARALLEL CURB RAMPS (TYPE 2B)**  
NOT TO SCALE

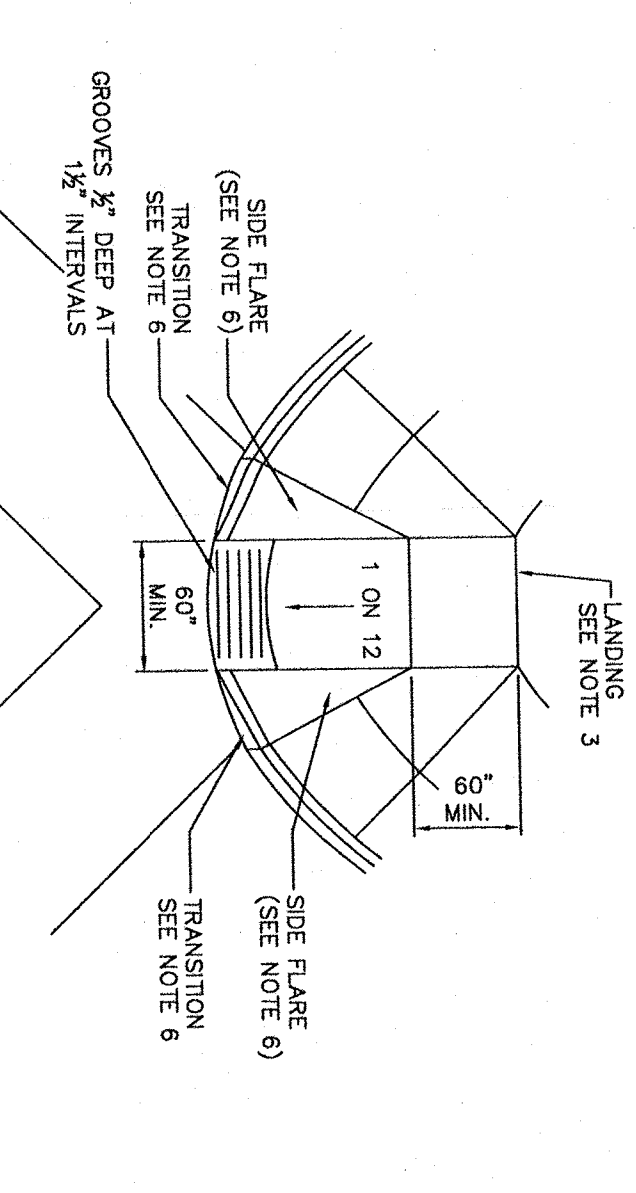

**DIAGONAL SIDEWALK CURB RAMP (TYPE 4)**  
NOT TO SCALE

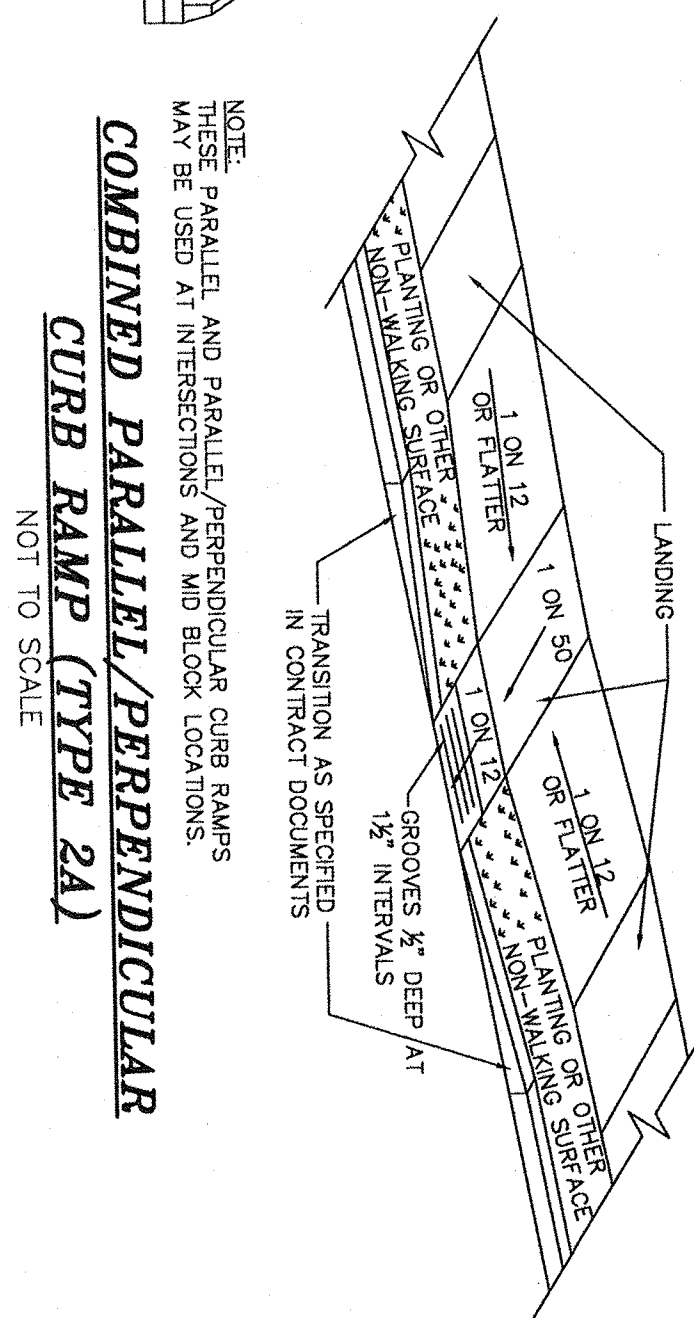

**COMBINED PARALLEL/PERPENDICULAR CURB RAMP (TYPE 2A)**  
NOT TO SCALE

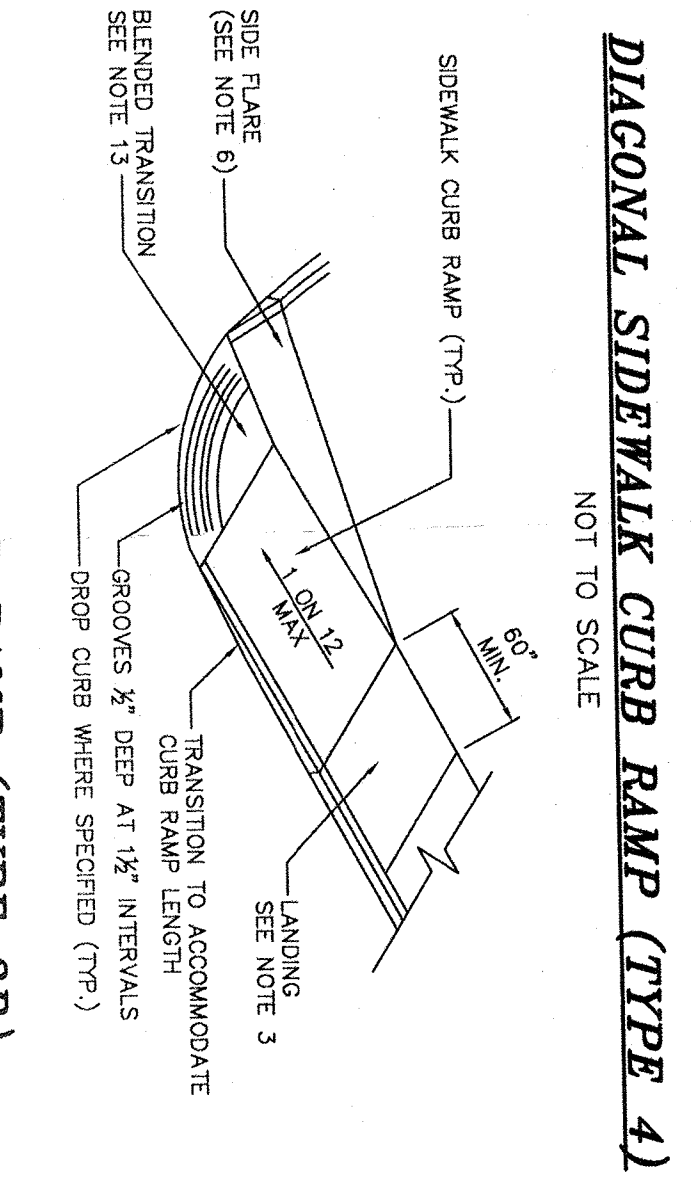

**SIDEWALK CURB RAMP (TYPE 3B)**  
NOT TO SCALE

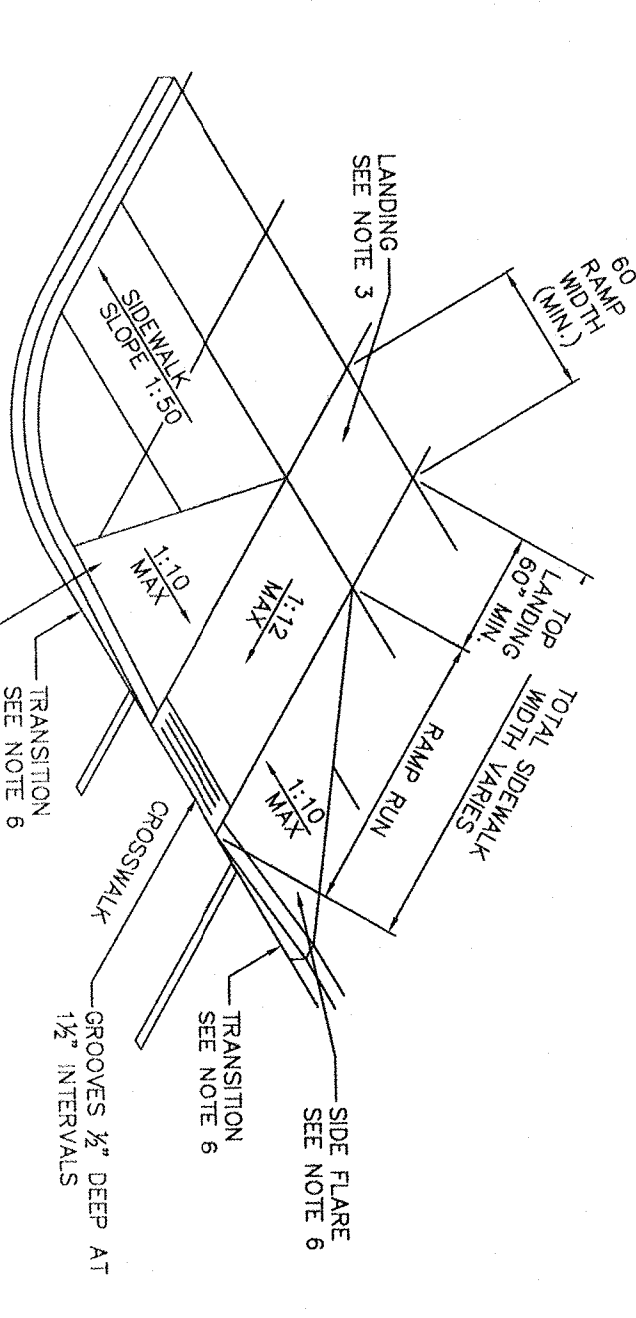

**PERPENDICULAR SIDEWALK CURB RAMP (TYPE 1)**  
NOT TO SCALE

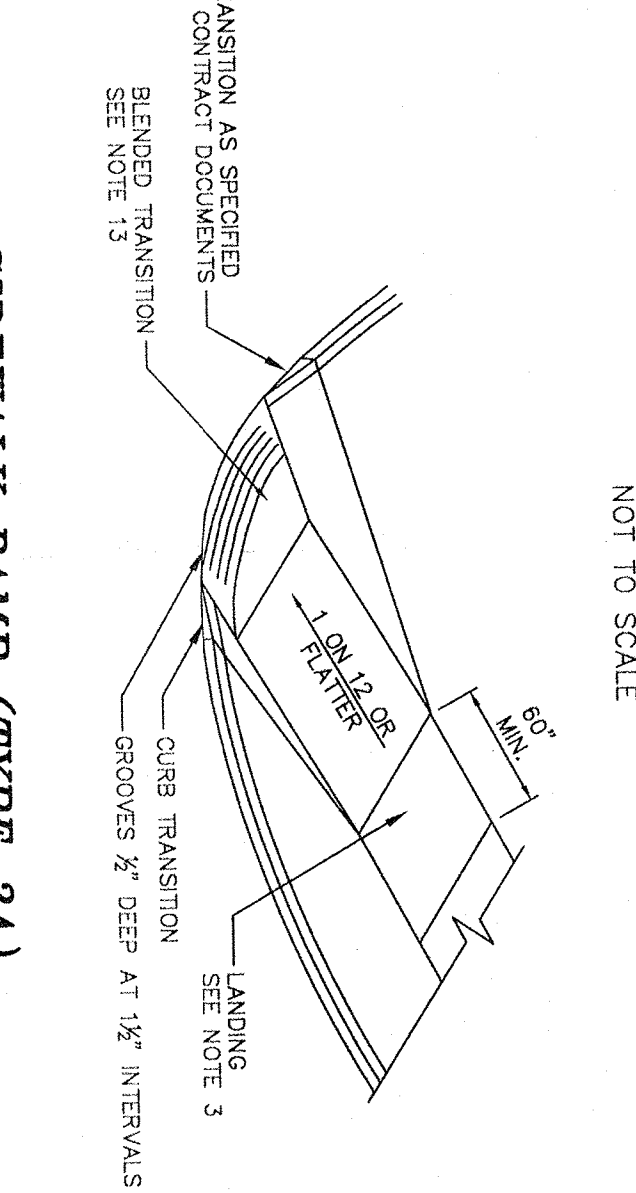

**SIDEWALK RAMP (TYPE 3A)**  
NOT TO SCALE

**COUNTER SLOPE CONDITIONS**

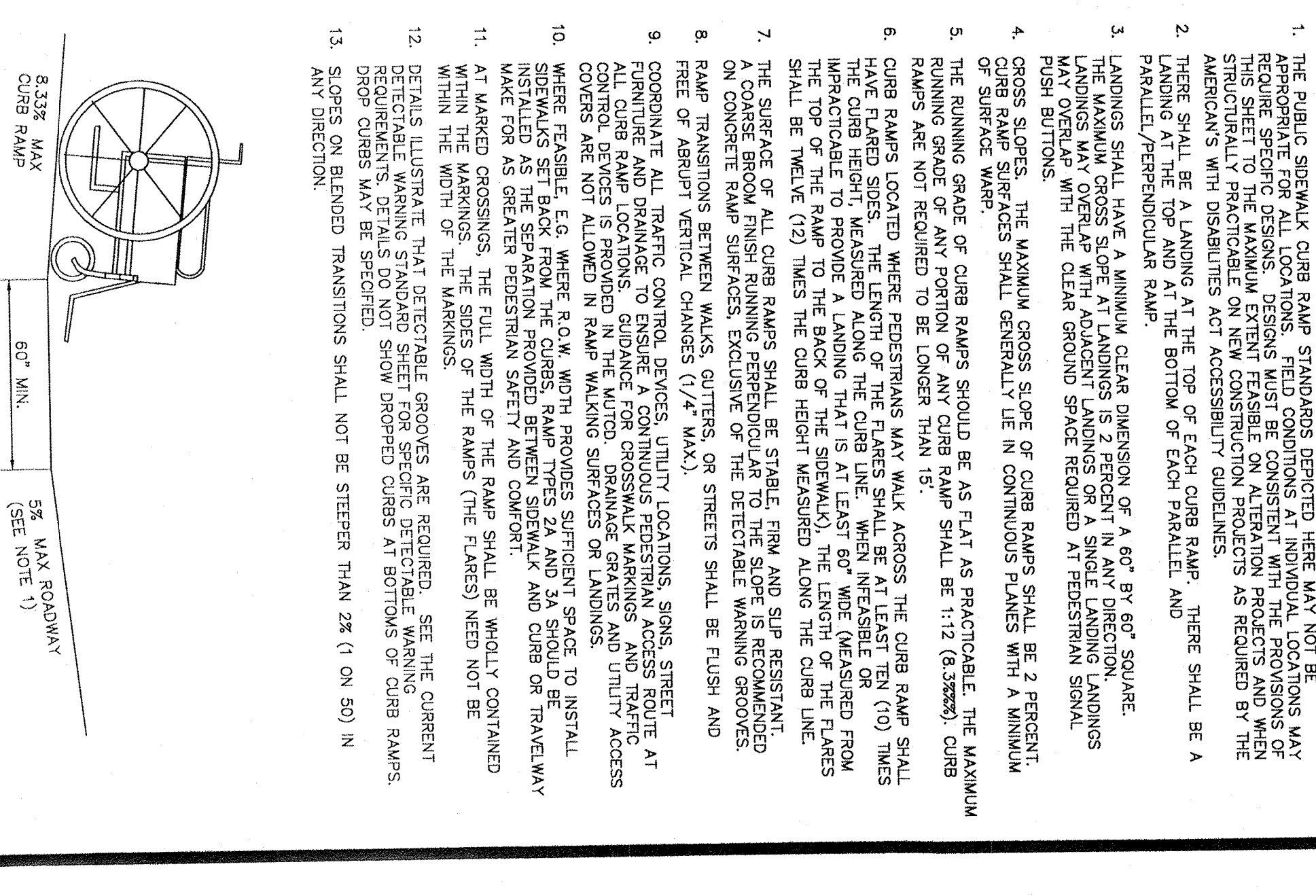

**COUNTER SLOPE CONDITIONS**  
NOT TO SCALE

**STANDARD SIDEWALK DETAIL**

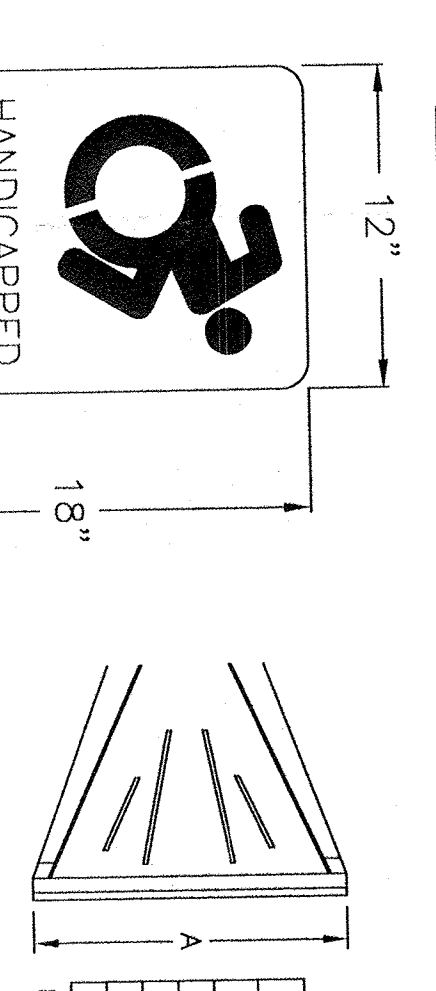

**STANDARD SIDEWALK DETAIL**  
NOT TO SCALE

PIPE DIAMETER	12"	15"	18"	24"	30"	36"
A	12	15	18	24	30	36
B	12	15	18	24	30	36
C	12	15	18	24	30	36
D	12	15	18	24	30	36
E	12	15	18	24	30	36
F	12	15	18	24	30	36
G	12	15	18	24	30	36
H	12	15	18	24	30	36
I	12	15	18	24	30	36
J	12	15	18	24	30	36
K	12	15	18	24	30	36
L	12	15	18	24	30	36
M	12	15	18	24	30	36
N	12	15	18	24	30	36
O	12	15	18	24	30	36
P	12	15	18	24	30	36
Q	12	15	18	24	30	36
R	12	15	18	24	30	36
S	12	15	18	24	30	36
T	12	15	18	24	30	36
U	12	15	18	24	30	36
V	12	15	18	24	30	36
W	12	15	18	24	30	36
X	12	15	18	24	30	36
Y	12	15	18	24	30	36
Z	12	15	18	24	30	36

**HDPE FLARED END SECTION**  
NOT TO SCALE

**PARKING SPACE STRIPING DETAIL**

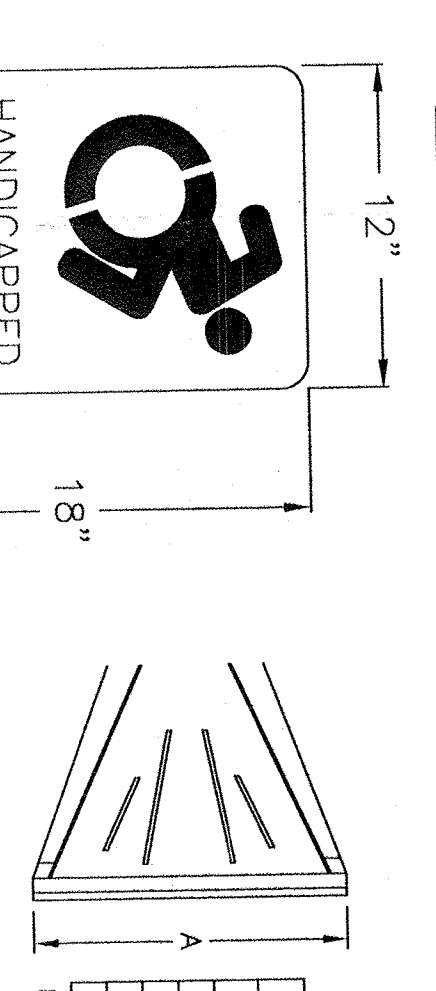

**PARKING SPACE STRIPING DETAIL**  
NOT TO SCALE

**HANDICAP SIGN**

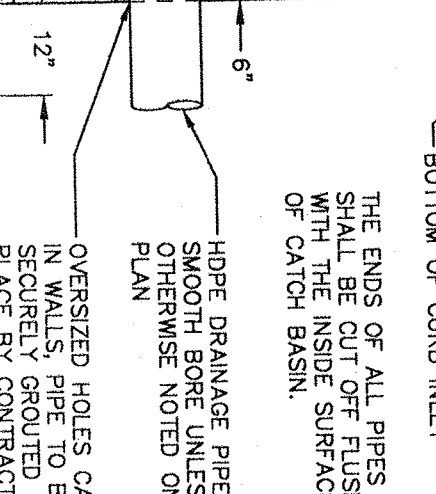

**HANDICAP SIGN**  
NOT TO SCALE

**CURB INLET-CATCH BASIN**

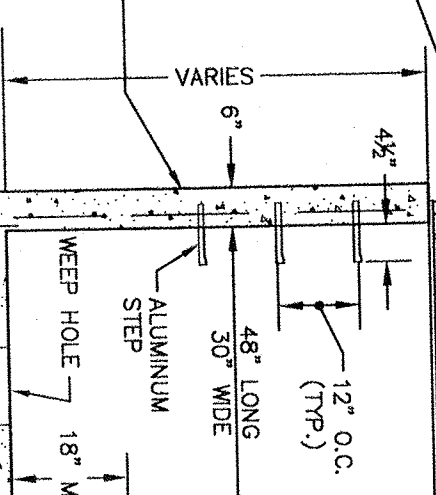

**CURB INLET-CATCH BASIN**  
NOT TO SCALE

**LOADING ZONE HATCH LINES**

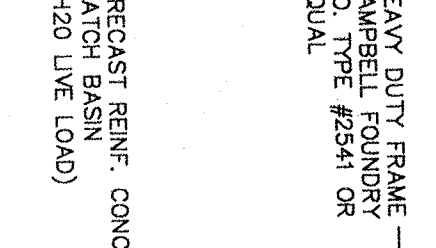

**LOADING ZONE HATCH LINES**  
N.T.S.

**PAVED ROAD - BITUMINOUS**

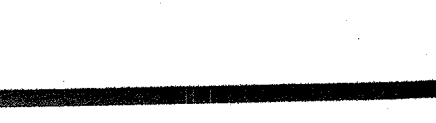

**PAVED ROAD - BITUMINOUS**  
NOT TO SCALE

**UNPAVED WAY**



**UNPAVED WAY**  
NOT TO SCALE

**GAZEBO DRIVE**



**GAZEBO DRIVE**  
NOT TO SCALE

**EARLY EXCAVATION**



**EARLY EXCAVATION**  
NOT TO SCALE

**TRENCH CROSS SECTION**

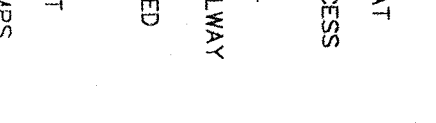

**TRENCH CROSS SECTION**  
NOT TO SCALE

**EARLY EXCAVATION**

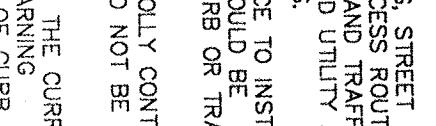

**EARLY EXCAVATION**  
NOT TO SCALE

**ROCK EXCAVATION**

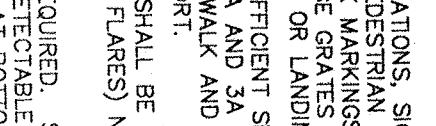

**ROCK EXCAVATION**  
NOT TO SCALE

**SEWER TRENCH CROSS SECTION**

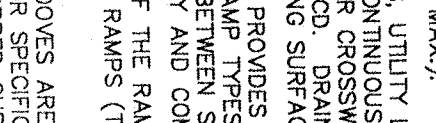

**SEWER TRENCH CROSS SECTION**  
NOT TO SCALE

**SEWER TRENCH CROSS SECTION**

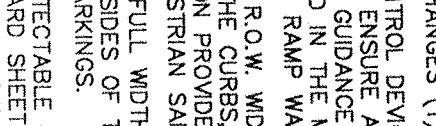

**SEWER TRENCH CROSS SECTION**  
NOT TO SCALE

**SEWER TRENCH CROSS SECTION**

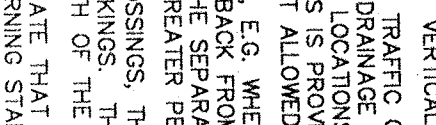

**SEWER TRENCH CROSS SECTION**  
NOT TO SCALE

**SEWER TRENCH CROSS SECTION**

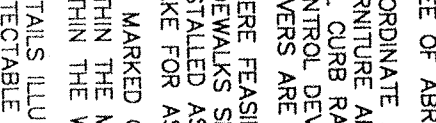

**SEWER TRENCH CROSS SECTION**  
NOT TO SCALE

**SEWER TRENCH CROSS SECTION**

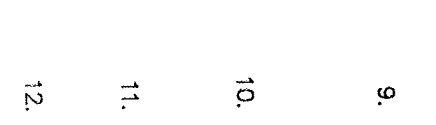

**SEWER TRENCH CROSS SECTION**  
NOT TO SCALE

**SEWER TRENCH CROSS SECTION**

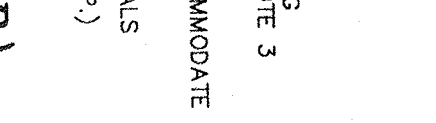

**SEWER TRENCH CROSS SECTION**  
NOT TO SCALE

**SEWER TRENCH CROSS SECTION**

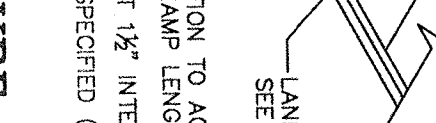

**SEWER TRENCH CROSS SECTION**  
NOT TO SCALE

**SEWER TRENCH CROSS SECTION**

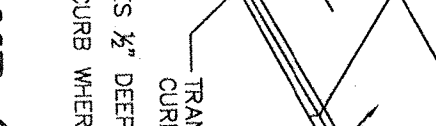

**SEWER TRENCH CROSS SECTION**  
NOT TO SCALE

**SEWER TRENCH CROSS SECTION**



**SEWER TRENCH CROSS SECTION**  
NOT TO SCALE

**SEWER TRENCH CROSS SECTION**



**SEWER TRENCH CROSS SECTION**  
NOT TO SCALE

**SEWER TRENCH CROSS SECTION**



**SEWER TRENCH CROSS SECTION**  
NOT TO SCALE

**SEWER TRENCH CROSS SECTION**

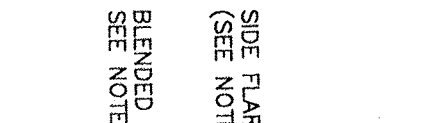

**SEWER TRENCH CROSS SECTION**  
NOT TO SCALE

**SEWER TRENCH CROSS SECTION**



**SEWER TRENCH CROSS SECTION**  
NOT TO SCALE

**SEWER TRENCH CROSS SECTION**

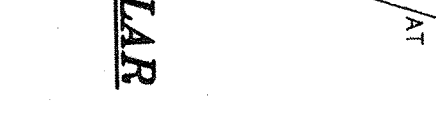

**SEWER TRENCH CROSS SECTION**  
NOT TO SCALE

**SEWER TRENCH CROSS SECTION**



**SEWER TRENCH CROSS SECTION**  
NOT TO SCALE

**SEWER TRENCH CROSS SECTION**

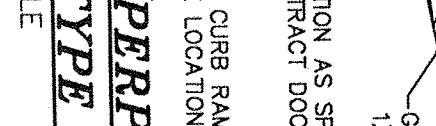

**SEWER TRENCH CROSS SECTION**  
NOT TO SCALE

**SEWER TRENCH CROSS SECTION**

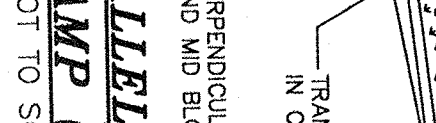

**SEWER TRENCH CROSS SECTION**  
NOT TO SCALE

**SEWER TRENCH CROSS SECTION**



**SEWER TRENCH CROSS SECTION**  
NOT TO SCALE

**SEWER TRENCH CROSS SECTION**



**SEWER TRENCH CROSS SECTION**  
NOT TO SCALE

**SEWER TRENCH CROSS SECTION**



**SEWER TRENCH CROSS SECTION**  
NOT TO SCALE

**SEWER TRENCH CROSS SECTION**



**SEWER TRENCH CROSS SECTION**  
NOT TO SCALE

**SEWER TRENCH CROSS SECTION**



**SEWER TRENCH CROSS SECTION**  
NOT TO SCALE

**SEWER TRENCH CROSS SECTION**

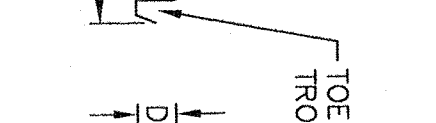

**SEWER TRENCH CROSS SECTION**  
NOT TO SCALE

**SEWER TRENCH CROSS SECTION**



**SEWER TRENCH CROSS SECTION**  
NOT TO SCALE

**SEWER TRENCH CROSS SECTION**

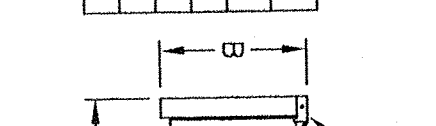

**SEWER TRENCH CROSS SECTION**  
NOT TO SCALE

**SEWER TRENCH CROSS SECTION**

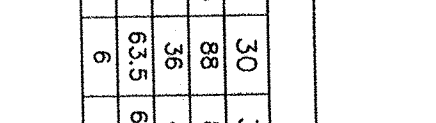

**SEWER TRENCH CROSS SECTION**  
NOT TO SCALE

**SEWER TRENCH CROSS SECTION**

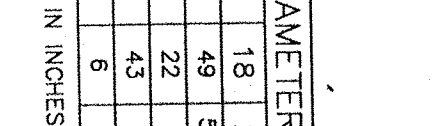

**SEWER TRENCH CROSS SECTION**  
NOT TO SCALE

**SEWER TRENCH CROSS SECTION**

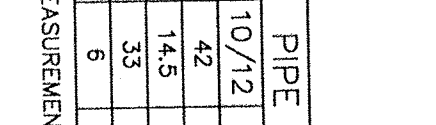

**SEWER TRENCH CROSS SECTION**  
NOT TO SCALE

**SEWER TRENCH CROSS SECTION**

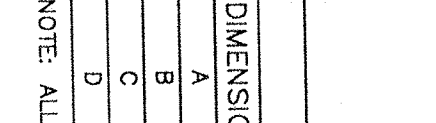

**SEWER TRENCH CROSS SECTION**  
NOT TO SCALE

**SEWER TRENCH CROSS SECTION**

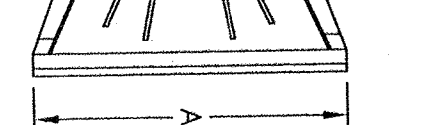

**SEWER TRENCH CROSS SECTION**  
NOT TO SCALE

**SEWER TRENCH CROSS SECTION**



**SEWER TRENCH CROSS SECTION**  
NOT TO SCALE

**SEWER TRENCH CROSS SECTION**

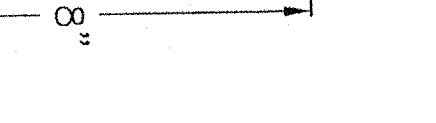

**SEWER TRENCH CROSS SECTION**  
NOT TO SCALE

**SEWER TRENCH CROSS SECTION**

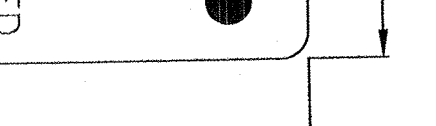

**SEWER TRENCH CROSS SECTION**  
NOT TO SCALE

**SEWER TRENCH CROSS SECTION**



**SEWER TRENCH CROSS SECTION**  
NOT TO SCALE

**SEWER TRENCH CROSS SECTION**



**SEWER TRENCH CROSS SECTION**  
NOT TO SCALE

**SEWER TRENCH CROSS SECTION**

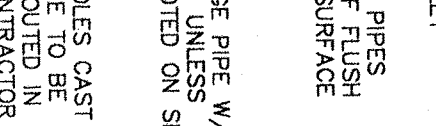

**SEWER TRENCH CROSS SECTION**  
NOT TO SCALE

**SEWER TRENCH CROSS SECTION**

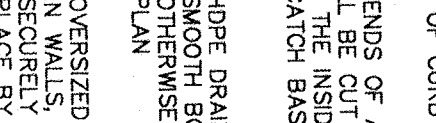

**SEWER TRENCH CROSS SECTION**  
NOT TO SCALE

**SEWER TRENCH CROSS SECTION**



**SEWER TRENCH CROSS SECTION**  
NOT TO SCALE

