

GENERAL NOTES AND SPECIFICATIONS
1. ALL WORK SHALL BE IN ACCORDANCE WITH THE PROVISIONS OF THE CODE AS LISTED IN THE SPECIFICATIONS.
2. THE CONTRACTOR SHALL BE RESPONSIBLE FOR OBTAINING ALL NECESSARY PERMITS AND INSURANCE.
3. THE CONTRACTOR SHALL MAINTAIN ACCESS TO ALL ADJACENT PROPERTIES AT ALL TIMES.

GENERAL NOTES AND SPECIFICATIONS
4. ALL MATERIALS AND EQUIPMENT SHALL BE NEW UNLESS OTHERWISE SPECIFIED.
5. THE CONTRACTOR SHALL BE RESPONSIBLE FOR PROTECTING EXISTING UTILITIES AND STRUCTURES.
6. ALL WORK SHALL BE COMPLETED WITHIN THE SPECIFIED TIME FRAME.

GENERAL NOTES AND SPECIFICATIONS
7. THE CONTRACTOR SHALL BE RESPONSIBLE FOR OBTAINING ALL NECESSARY PERMITS AND INSURANCE.
8. THE CONTRACTOR SHALL MAINTAIN ACCESS TO ALL ADJACENT PROPERTIES AT ALL TIMES.
9. ALL MATERIALS AND EQUIPMENT SHALL BE NEW UNLESS OTHERWISE SPECIFIED.

GENERAL NOTES AND SPECIFICATIONS
10. THE CONTRACTOR SHALL BE RESPONSIBLE FOR OBTAINING ALL NECESSARY PERMITS AND INSURANCE.
11. THE CONTRACTOR SHALL MAINTAIN ACCESS TO ALL ADJACENT PROPERTIES AT ALL TIMES.
12. ALL MATERIALS AND EQUIPMENT SHALL BE NEW UNLESS OTHERWISE SPECIFIED.

GENERAL NOTES AND SPECIFICATIONS
13. THE CONTRACTOR SHALL BE RESPONSIBLE FOR OBTAINING ALL NECESSARY PERMITS AND INSURANCE.
14. THE CONTRACTOR SHALL MAINTAIN ACCESS TO ALL ADJACENT PROPERTIES AT ALL TIMES.
15. ALL MATERIALS AND EQUIPMENT SHALL BE NEW UNLESS OTHERWISE SPECIFIED.

GENERAL NOTES AND SPECIFICATIONS
16. THE CONTRACTOR SHALL BE RESPONSIBLE FOR OBTAINING ALL NECESSARY PERMITS AND INSURANCE.
17. THE CONTRACTOR SHALL MAINTAIN ACCESS TO ALL ADJACENT PROPERTIES AT ALL TIMES.
18. ALL MATERIALS AND EQUIPMENT SHALL BE NEW UNLESS OTHERWISE SPECIFIED.

GENERAL NOTES AND SPECIFICATIONS
19. THE CONTRACTOR SHALL BE RESPONSIBLE FOR OBTAINING ALL NECESSARY PERMITS AND INSURANCE.
20. THE CONTRACTOR SHALL MAINTAIN ACCESS TO ALL ADJACENT PROPERTIES AT ALL TIMES.
21. ALL MATERIALS AND EQUIPMENT SHALL BE NEW UNLESS OTHERWISE SPECIFIED.

GENERAL NOTES AND SPECIFICATIONS
22. THE CONTRACTOR SHALL BE RESPONSIBLE FOR OBTAINING ALL NECESSARY PERMITS AND INSURANCE.
23. THE CONTRACTOR SHALL MAINTAIN ACCESS TO ALL ADJACENT PROPERTIES AT ALL TIMES.
24. ALL MATERIALS AND EQUIPMENT SHALL BE NEW UNLESS OTHERWISE SPECIFIED.

GENERAL NOTES AND SPECIFICATIONS
25. THE CONTRACTOR SHALL BE RESPONSIBLE FOR OBTAINING ALL NECESSARY PERMITS AND INSURANCE.
26. THE CONTRACTOR SHALL MAINTAIN ACCESS TO ALL ADJACENT PROPERTIES AT ALL TIMES.
27. ALL MATERIALS AND EQUIPMENT SHALL BE NEW UNLESS OTHERWISE SPECIFIED.

GENERAL NOTES AND SPECIFICATIONS
28. THE CONTRACTOR SHALL BE RESPONSIBLE FOR OBTAINING ALL NECESSARY PERMITS AND INSURANCE.
29. THE CONTRACTOR SHALL MAINTAIN ACCESS TO ALL ADJACENT PROPERTIES AT ALL TIMES.
30. ALL MATERIALS AND EQUIPMENT SHALL BE NEW UNLESS OTHERWISE SPECIFIED.

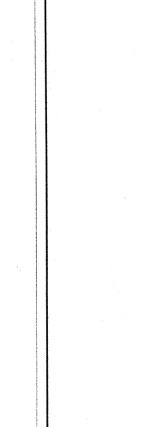
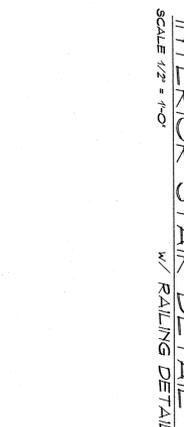
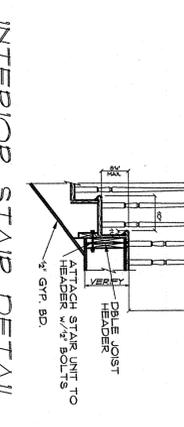
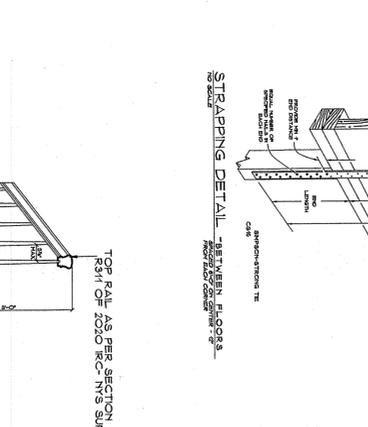
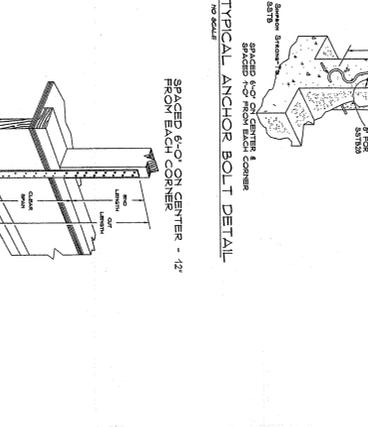
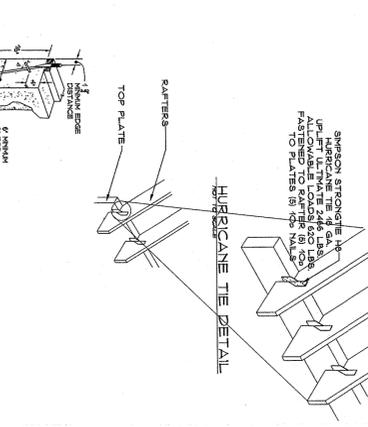
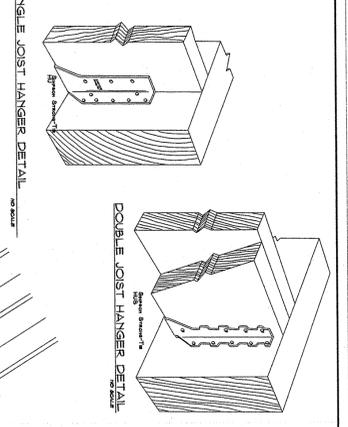

Table with 2 columns: DATE (Issue For Construction, MAY 3, 2021) and SHEET (2 OF 5).

PROPOSED SINGLE FAMILY RESIDENCE FOR JNF ENTERPRISES INC. 268 NORTH MIDDLETOWN ROAD HAMLET OF PEARL RIVER TOWN OF ORANGETOWN, NEW YORK

GENERAL NOTES & SPECIFICATIONS

John Perkins ARCHITECT. Professional Limited Liability Company. N.C.A.R.B. Certified. 845-429-4225 www.JPerkinsArchitect.com

Table with 2 columns: REVISION and DRAWING TITLE.

PLANS VALID FOR PERMIT & CONSTRUCTION ONLY IF SIGNED AND SEALED

PROPOSED SECOND FLOOR PLAN

ALL NOTES UNLESS NOTED OTHERWISE ON PLANS VARY DUE TO GYPHUM BOARD DIMENSIONS AND TO NEAREST 1/8" AS SHOWN. CLEAN & FREE FROM ROT & DEFECTS. HAVING A MINIMUM BENDING STRESS OF 1300 PSI.

CONCRETE SHALL BE 3000 PSI. ALL CONCRETE SHALL BE CAST WITH PROPER CURING AND PROTECTION FROM WEATHER. ALL CONCRETE SHALL BE CAST WITH PROPER CURING AND PROTECTION FROM WEATHER.

ALL JOISTS UNDER ALL PARTITIONS RUNNING PARALLEL TO JOIST SPANS. ALL JOISTS UNDER ALL PARTITIONS RUNNING PARALLEL TO JOIST SPANS. ALL JOISTS UNDER ALL PARTITIONS RUNNING PARALLEL TO JOIST SPANS.

ALL JOISTS UNDER ALL PARTITIONS RUNNING PARALLEL TO JOIST SPANS. ALL JOISTS UNDER ALL PARTITIONS RUNNING PARALLEL TO JOIST SPANS. ALL JOISTS UNDER ALL PARTITIONS RUNNING PARALLEL TO JOIST SPANS.

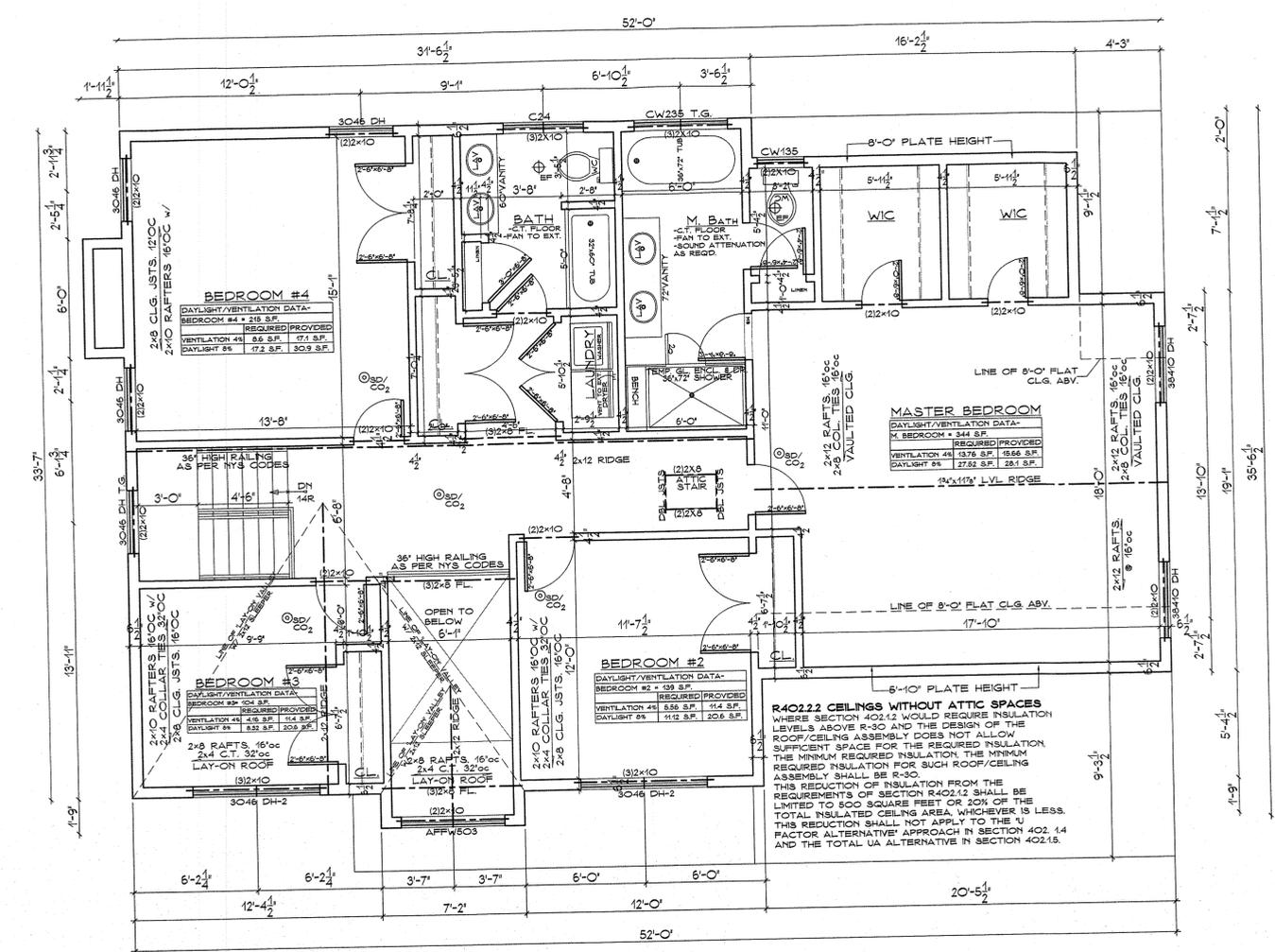

PROJECT SCHEDULE

GENERAL PUBLIC ALL NON-CONSTRUCTION RELATED PROJECT SITE CONDITIONS. GENERAL PUBLIC ALL NON-CONSTRUCTION RELATED PROJECT SITE CONDITIONS. GENERAL PUBLIC ALL NON-CONSTRUCTION RELATED PROJECT SITE CONDITIONS.

GENERAL PUBLIC ALL NON-CONSTRUCTION RELATED PROJECT SITE CONDITIONS. GENERAL PUBLIC ALL NON-CONSTRUCTION RELATED PROJECT SITE CONDITIONS. GENERAL PUBLIC ALL NON-CONSTRUCTION RELATED PROJECT SITE CONDITIONS.

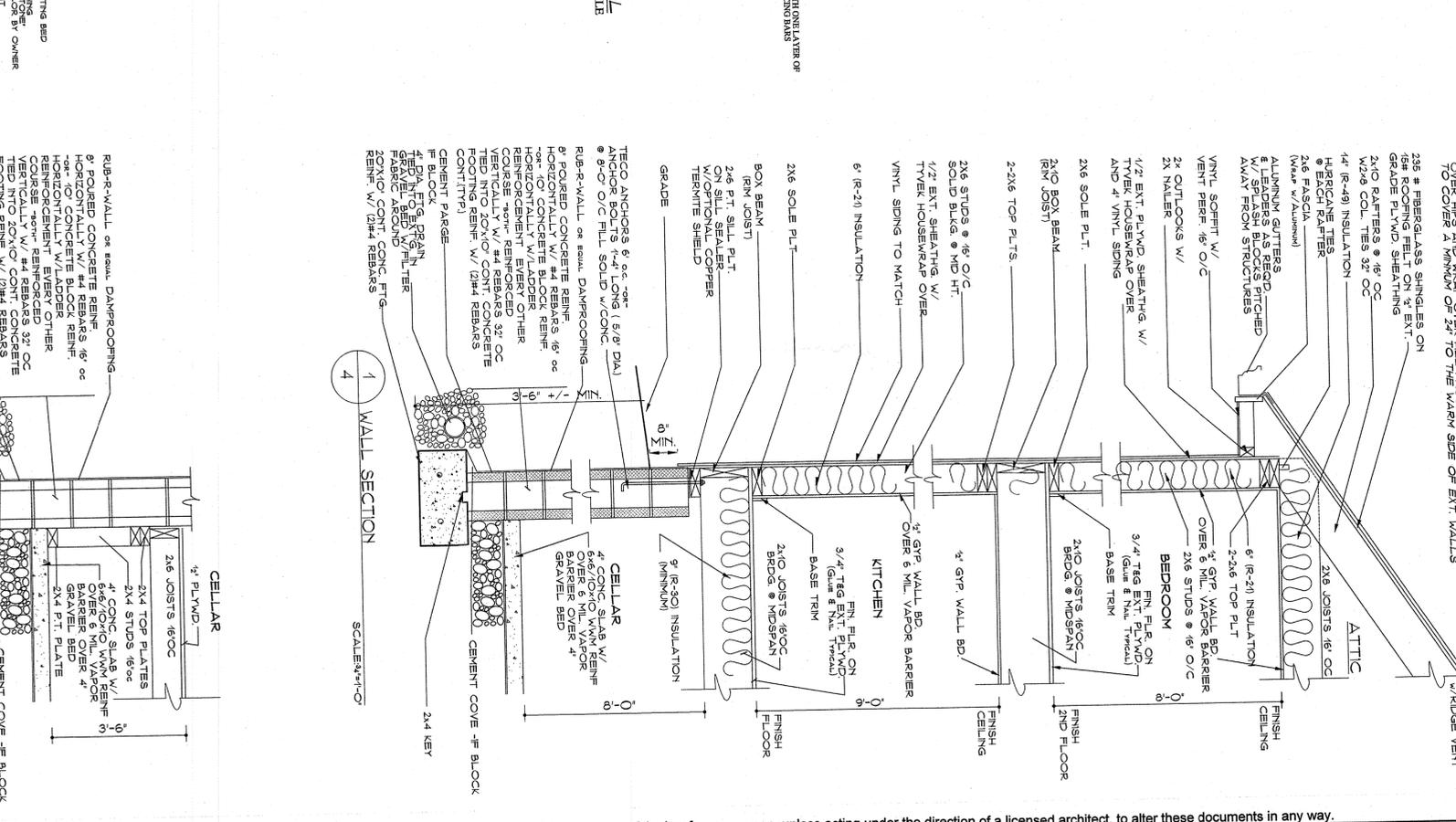
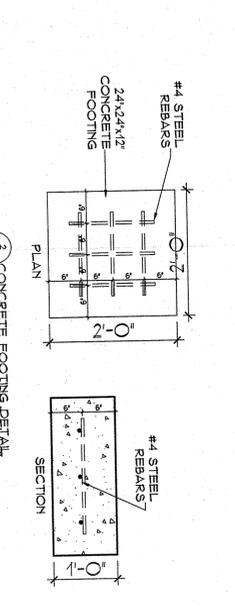
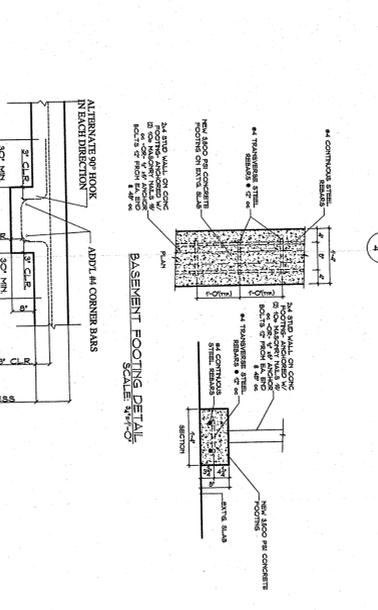
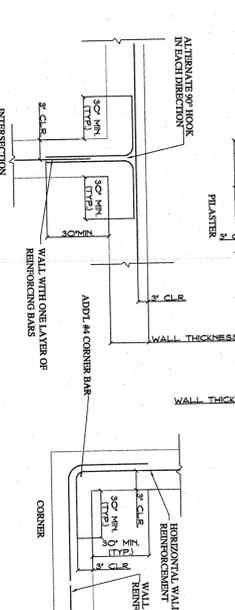
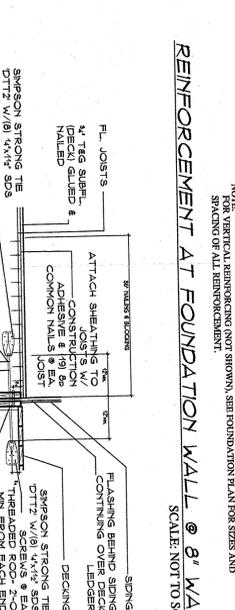
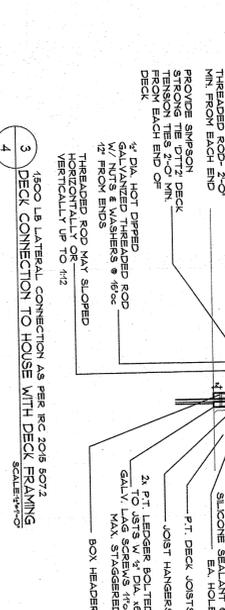
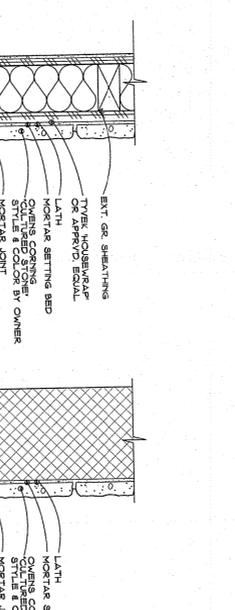

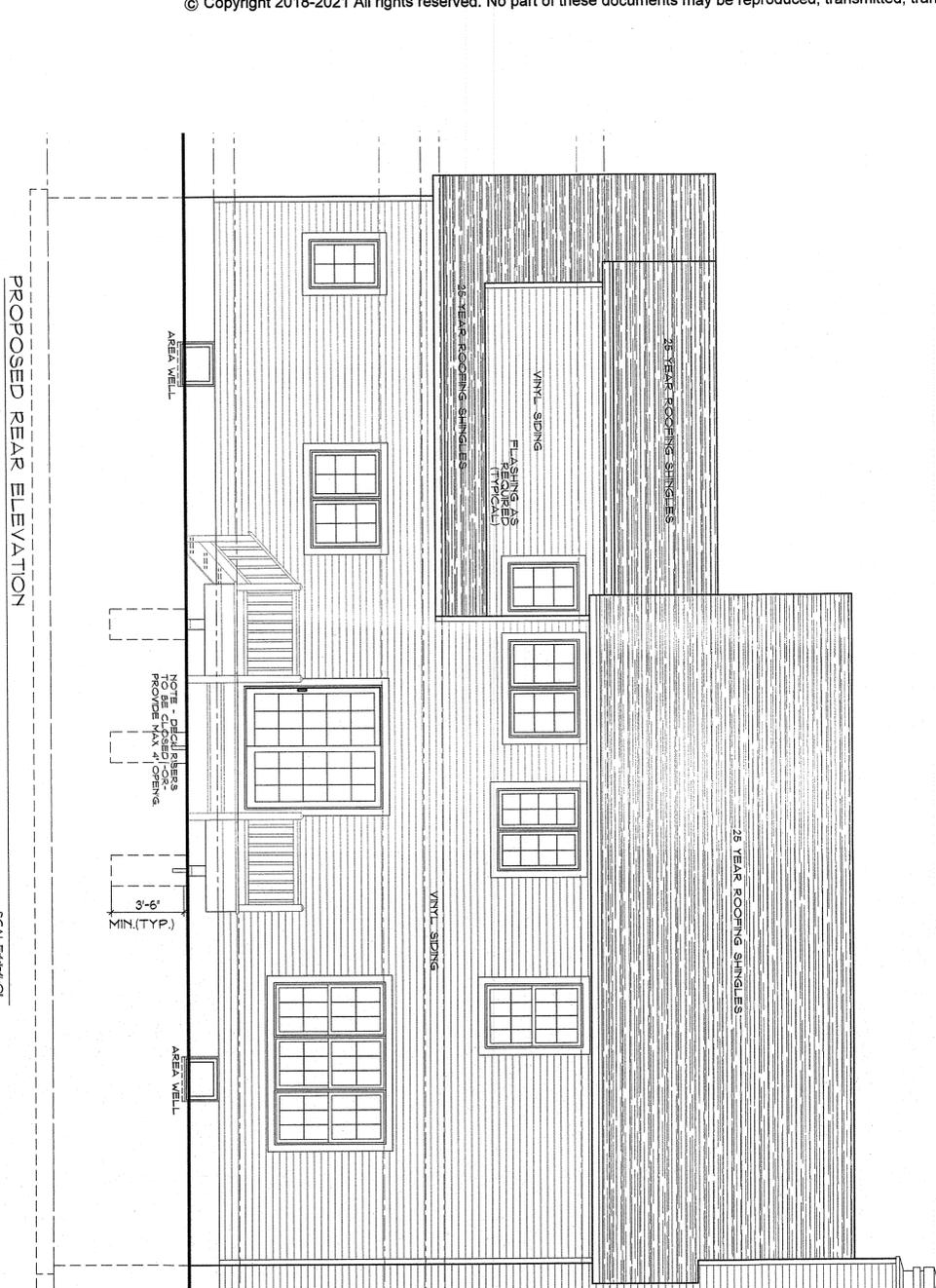
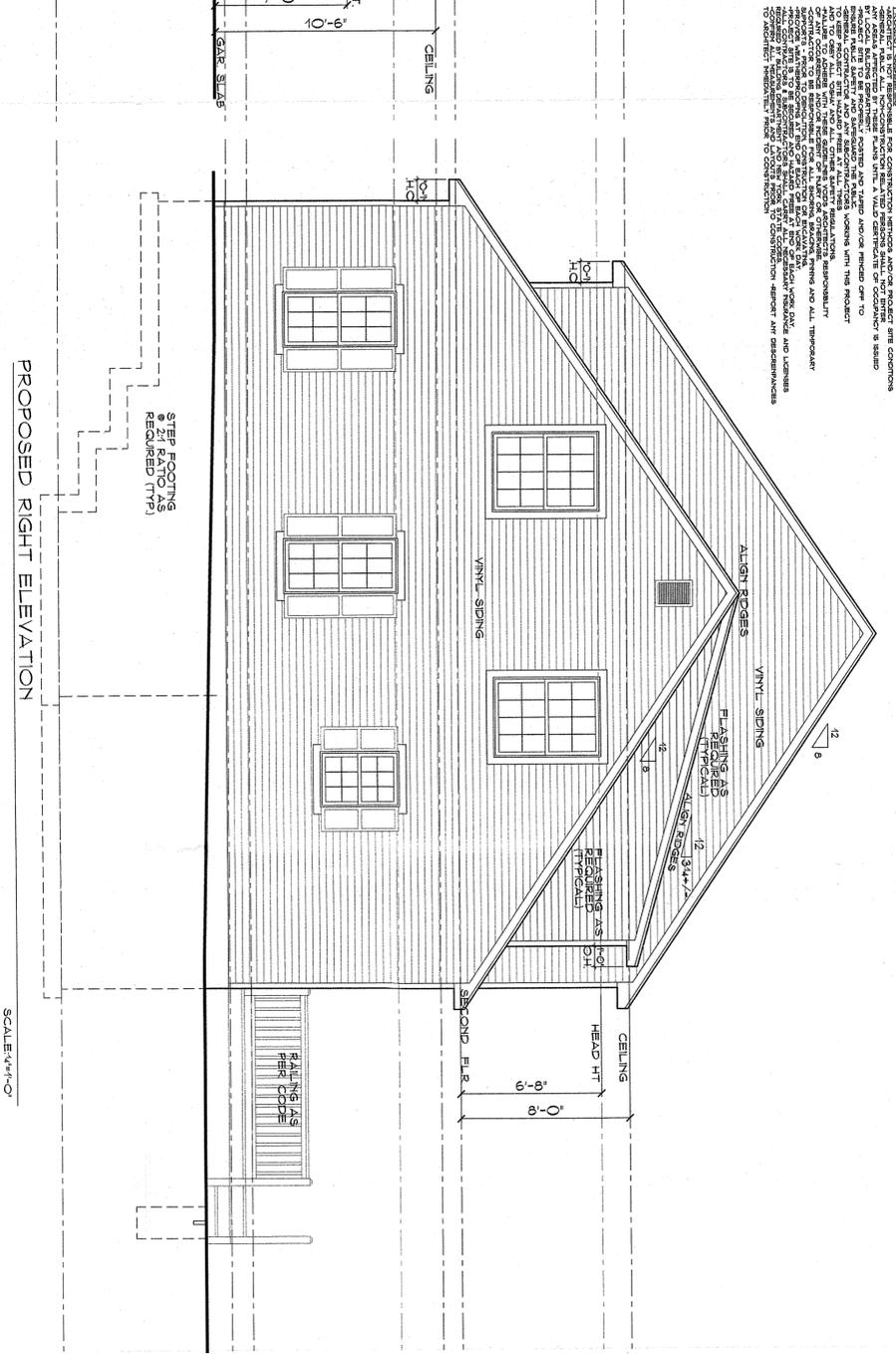
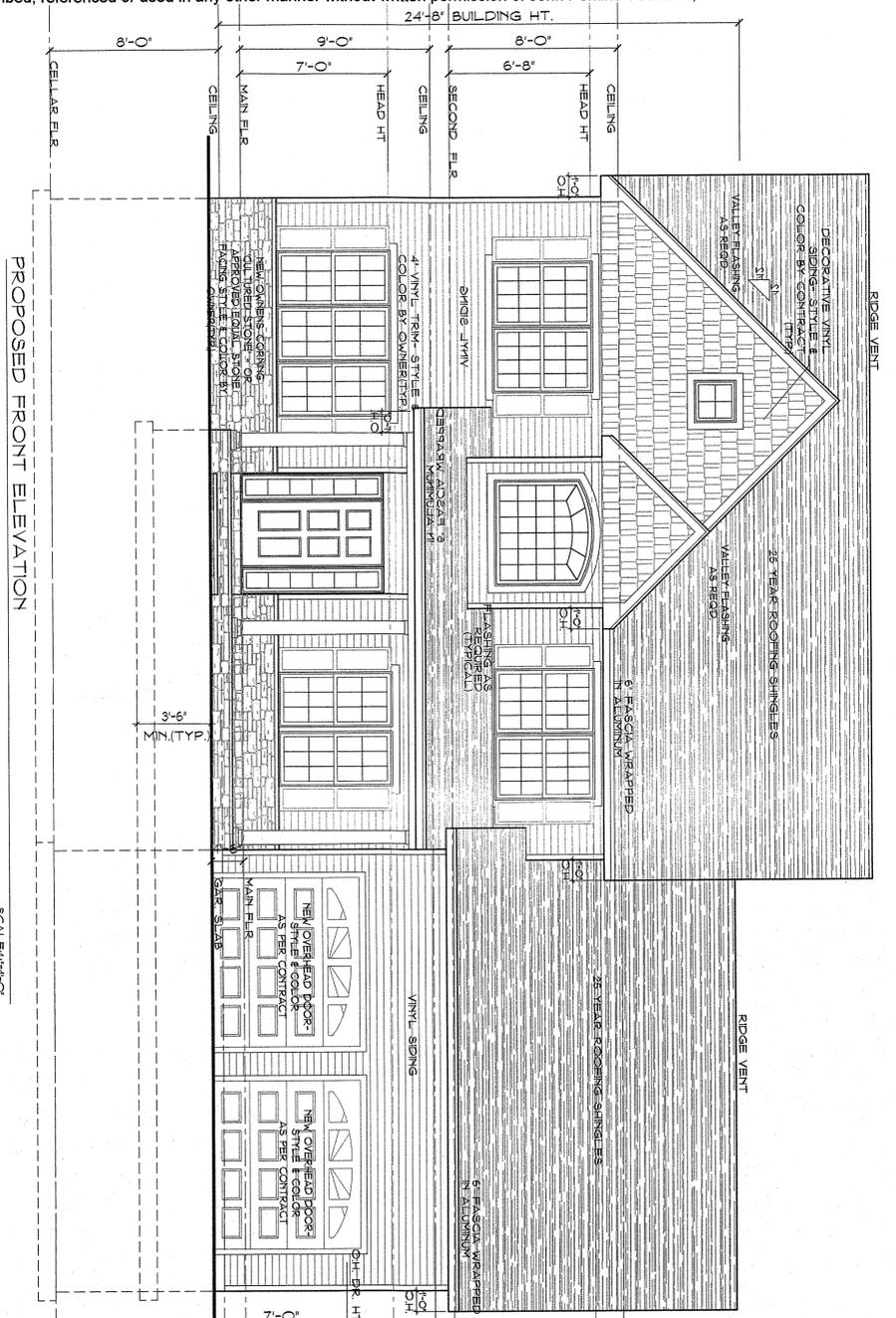

PROJECT: 268 NORTH MIDDLETOWN ROAD, ORANGETOWN, NY
 ARCHITECT: JOHN PERKINS ARCHITECT, PLLC
 DATE: MAY 3, 2021
 SHEET: 5 OF 5

PLANS VALID FOR PERMIT & CONSTRUCTION ONLY IF SIGNED AND SEALED

Note: it is a violation of the law for any person, unless acting under the direction of a licensed architect, to alter these documents in any way.

REVISION

John Perkins
 ARCHITECT.
 Professional Limited Liability Company
 N.C.A.R.B. Certified
 NYS License: 02950-1
 NY License: 2143016470
 Post Office Box 271 Tonawanda, New York 14266
 (845) 429-4225 www.JPerkinsArchitect.com

DRAWING TITLE:
ELEVATIONS

PROPOSED SINGLE FAMILY RESIDENCE
 FOR
JNF ENTERPRISES INC.
 268 NORTH MIDDLETOWN ROAD
 HAMLET OF PEARL RIVER
 TOWN OF ORANGETOWN, NEW YORK

DATE
 Issue For Construction
 MAY 3, 2021

SHEET:
5
 OF
5